

UNIVERSAL
LIBRARY



141 222

UNIVERSAL
LIBRARY

THE NATURAL HISTORY OF CRYSTALS

THE NATURAL HISTORY
OF
CRYSTALS

BY

A. E. H. TUTTON

D.Sc., M.A. (NEW COLLEGE, OXON), F.R.S.

PAST PRESIDENT OF THE MINERALOGICAL SOCIETY

WITH 166 ILLUSTRATIONS

INCLUDING 32 HALF-TONE PLATES AND FRONTISPIECE IN COLOUR

LONDON

KEGAN PAUL, TRENCH, TRUBNER & CO. LTD.

NEW YORK: E. P. DUTTON & CO.

1924

Printed in Great Britain at
The Mayflower Press, Plymouth. William Brendon & Son, Ltd

PREFACE

THE foundation of this book is the volume of the International Scientific Series entitled "Crystals," which was published in the Year 1911. But it is much more than merely a revised edition of that work, for it has been so largely rewritten, and has had so much absolutely new matter added, that it is practically a new book, and is produced in an entirely different form. For since the year 1911 a new outlook on the subject of Crystals has been opened up by the discovery of Dr. M. Laue, now Professor of Physics at Zurich, that the regularly arranged parallel planes of atoms within a crystal are capable of diffracting and reflecting X-rays, and that these diverted rays afford a direct revelation of the crystal symmetry, when they are received on the usual fluorescent screen or sensitive photographic plate. The startling announcement of this remarkable fact called forth the deepest interest. The moment was an anxious one for those who had laboriously arrived at the probable structure and nature of crystals by the paths of prolonged investigation of their external faceted forms, of their internal optical and other physical properties, and of their relative densities and volumes; and also for those who, recognising crystals as essentially homogeneous solids, had by various methods of geometrical deduction arrived at the possible types of homogeneous structures possessing the known attributes of crystals. That is, a crucial test had been discovered, of the verity or fallaciousness of the views as to the nature of crystals which had been described in the simplest possible language in the author's earlier book. Would the new and immensely powerful means of research—the direct approach—confirm these principles concerning the arrangement of the atoms in crystals, so uniformly indicated by all indirect experimental work and by the soundest geometrical conceptions, or would it show that the labour of years had led to a wrong purview altogether?

Happily, however, the patient work on the part of so many

For facilities and material for illustrations the author desires to offer his most cordial thanks to Sir William Bragg, Prof. W. L. Bragg, Prof. von Laue, Prof. F. M. Jaeger, Sir Henry Miers, Miss Mary Porter, The Royal Institution, The Royal Society of Arts, and Messrs. Macmillan and Co.

The text of the book is intended for the general reader more or less interested in natural science, while the lengthy Glossary will render it of real use to those who desire to commence an actual study of the subject.

If the perusal of the book should lead to a desire to go more fully, deeply, and seriously into the subject of Crystallography, it is hoped that the Second Edition published in 1922 by Messrs. Macmillan, in two volumes, of the author's "Crystallography and Practical Crystal Measurement" will afford all necessary aid in doing so.

A. E. H. TUTTON.

November, 1923.

investigators and during so many years has had its reward, for the new mode of research by X-rays, which has been so admirably developed in this country by our greatest expert on X-rays, Prof. Sir William H. Bragg, ably assisted by his son Prof. W. L. Bragg, has afforded absolute and most welcome confirmation of practically the whole of the natural history of crystals as laid down in the former book. While some few of the more purely speculative ideas, which the author ever deprecated, such as the valency volume theory of Pope and Barlow, are not confirmed, the whole of the results based on actual experiment, and the geometrical theory of crystals which regards them as possible types of homogeneous structure—the perfected work of Bravais, Sohncke, Schoenflies, Fedorov and Barlow—are all found to be in essential agreement with the results of X-ray analysis. The purpose of this new book, therefore, is to re-tell the story in the light of the new X-ray results, and a special chapter of some considerable length is interpolated half-way through the book, in which the new method and the chief of the results obtained by its means are described, together with such details of the mode of experimenting as will appeal to the general reader. The book is right up to date, to November, 1923, all new facts which the most recent investigation has brought to light bearing on the theories of crystal structure and on the chemistry and physics of solids being included. In particular, a concise account of the recent researches which have revealed the structure and nature of the atom, one of the most fascinatingly interesting advances of this remarkable epoch, is given in Chapter X. Many new illustrations are given, and it is hoped that the book may faithfully and exactly reflect the present state of our real knowledge of the subject, that portion, in fact, which is now so firmly based—thanks to the powerful probe of X-radiation—as to be open to no further doubt.

In response to the suggestion of a friendly critic of the former book, a Glossary has been added in which brief explanations are given of the technical terms which it has been unavoidably necessary to use in the book. It is hoped that readers who do not find such terms adequately explained in the text at all, or not on the page where they are reading, will find such concise explanation as they require in this concluding Glossary.

For facilities and material for illustrations the author desires to offer his most cordial thanks to Sir William Bragg, Prof. W. L. Bragg, Prof. von Laue, Prof. F. M. Jaeger, Sir Henry Miers, Miss Mary Porter, The Royal Institution, The Royal Society of Arts, and Messrs. Macmillan and Co.

The text of the book is intended for the general reader more or less interested in natural science, while the lengthy Glossary will render it of real use to those who desire to commence an actual study of the subject.

If the perusal of the book should lead to a desire to go more fully, deeply, and seriously into the subject of Crystallography, it is hoped that the Second Edition published in 1922 by Messrs. Macmillan, in two volumes, of the author's "Crystallography and Practical Crystal Measurement" will afford all necessary aid in doing so.

A. E. H. TUTTON.

November, 1923.

CONTENTS

CHAPTER		PAGE
	Preface	v
I.	Introduction	1
II.	The Masking of Similarity of Symmetry and Constancy of Angle by Difference of Habit, and its Influence on Early Studies of Crystals	7
III.	The prescient Work of the Abbé Haüy	15
IV.	The Seven Styles of Crystal Architecture	22
V.	How Crystals are Described. The Simple Law limiting the Number of possible Forms	34
VI.	How a Crystal grows from a Solution	42
VII.	The Distribution of Crystal Faces in Zones, and the Mode of Constructing a Plan of the Faces. The Reflecting Goniometer	53
VIII.	The Work of Eilhardt Mitscherlich and his Discovery of Isomorphism	61
IX.	Morphotropy as distinct from Isomorphism	78
X.	The Nature of Atoms. The Units of Crystal Structure. The Crystal Space-Lattice and its Molecular or Polymolecular Unit Cell. The 230 Point-Systems of Homogeneous Crystal Structure	86
XI.	Law of Variation of Angles in Isomorphous Series. Relative Dimensions of Unit Cells. Fixity of Atoms in Crystal	98
XII.	The Revelation of Crystal Structure by X-rays. The Law of Atomic Diameters	108
XIII.	Polymorphism and its Explanation	147

CHAPTER	PAGE
XIV. Enantiomorphism of Crystalline Form and Optical Activity	154
XV. Effect of the Symmetry of Crystals on the Passage of Light through them. Quartz, Calcite, and Gypsum as Examples	169
XVI. Experiments with Crystals in Convergent Polarised Light. Quartz, as an Example of Mirror-Image Symmetry and its accompanying Optical Activity	182
XVII. Experiments with Quartz and Gypsum in Parallel Polarised Light. General Conclusions from the Experiments with Quartz	193
XVIII. "Liquid Crystals"	215
XIX. Other Physical Properties of Crystals and their Study	233
XX. The Chemical Significance of Crystallography. The Theory of Pope and Barlow, of Sollas, and of Fedorov. Crystallochemical Analysis	240
XXI. Conclusion	250
Appendix I. Glossary of Technical Terms	253
Appendix II. List of the 32 Classes of Crystals and their Distribution among the Seven Systems	271
Appendix III. The Periodic Classification of the Elements	275
Index	277

LIST OF 32 FULL-PAGE PLATES

	Fig. 133. Natural Quartz Twin in Parallel Polarised Light .	
	Fig. 140. Benzoic Acid Crystals in Act of Growth in Polarised Light	} <i>Frontispiece</i>
PLATE		FACING PAGE
I.	Fig. 2. Monoclinic Acicular Crystals of Sulphur	2
	Fig. 3. Octahedral Crystals of Arsenious Oxide	2
II.	Fig. 4. Octahedral Crystals of Potash Alum	4
III.	Fig. 6. Hexagonal Prisms of Calcite terminated by Rhombohedra	8
	Fig. 7. Scalenohedral Crystals of Calcite, "Dog-tooth Spar"	8
IV.	Fig. 10. Micro-Chemical Crystals of Gypsum (Calcium Sulphate)	10
V.	Fig. 24. Octahedra of Potassium Cadmium Cyanide	28
	Fig. 25. Octahedra of Cæsium Alum	28
VI.	Fig. 26. Octahedra of Ammonium Iron Alum crystallising on a Hair (after V)	28
	Fig. 27. Tetragonal Crystals of Potassium Ferrocyanide (after V)	28
VII.	Fig. 28. Rhombic Crystals of Potassium Hydrogen Tartrate (after VI)	28
	Fig. 29. Rhombic Crystals of Ammonium Magnesium Phosphate (after VI)	28
VIII.	Fig. 30. Monoclinic Crystals of Ammonium Magnesium Sulphate	30
	Fig. 31. Monoclinic Crystals of Sodium Potassium Carbonate	30
IX.	Fig. 32. Triclinic Crystals of Potassium Ferricyanide . (after VIII)	30
	Fig. 33. Tetrahedral Crystals of Sodium Sulphantimoniate (after VIII)	30
X.	Fig. 34. Liquid Cavities in Quartz Crystal (after IX)	30
	Fig. 36. Two Characteristic Forms of Snow Crystals . (after IX)	30
XI.	Fig. 37. Piz Palù and Snow-field of the Pers Glacier, from the Diavolezza Pass	32
XII.	Fig. 48. Potassium Bichromate slowly crystallising from a Metastable Solution	48
	Fig. 49. Potassium Bichromate rapidly crystallised from a Labile Solution	48
XIII.	Fig. 50. Ammonium Chloride crystallising from a Labile Supersaturated Solution	72
	Fig. 55. Rhombic Needles and Cubic Octahedra of Antimony Trioxide	72
XIV.	Figs. 57, 58, 59, and 60. Four Stages in the Mitscherlich Experiment with Gypsum	74
XV.	Fig. 63. Interference Figures in Convergent Polarised Light of Ethyl Triphenyl Pyrrholone	82
XVI.	Fig. 68. Original Laue X-Radiogram of Zinc Blende	108

		FACING PAGE
XVII.	Fig. 86. Beryl. Plate parallel (0001)	128
XVIII.	Fig. 87. Topaz. Plate parallel (001)	128
	Fig. 88. Anhydrite. Plate parallel (001)	128
XIX.	Fig. 104. A Crystal of Sulphur, the usual rhombic form	150
	Fig. 113. Photomicrograph of Graphitic Granite	150
XX.	Fig. 115. Uniaxial Interference Figure of Calcite	186
	Figs. 116 and 117. Biaxial Interference Figures of Aragonite	186
XXI.	Figs. 119 and 120. Uniaxial Interference Figures of Quartz	188
	Fig. 121. Airy's Spirals afforded by two superposed Quartz Plates	188
XXII.	Fig. 125. Ten Diamonds exhibiting Natural Faces	196
XXIII.	Fig. 130. Natural Biquartz, 3.75 mm. thick, exhibiting Black Band	202
	Fig. 131. Artificial Biquartz, 7.5 mm. thick, obliquely joined to produce Black Band	202
XXIV.	Fig. 132. Babinet's Composite Plate of two Quartz Wedges showing Bands in polarised light	204
	Fig. 134. Sectorial Twinning of Right and Left Quartz	204
XXV.	Fig. 135. Irregular Twinning of Right and Left Quartz	206
	Fig. 136. Amethyst Quartz showing Sectorial Repeated Twinning of Right and Left Varieties	206
XXVI.	Fig. 137. Section-plate of Amethyst showing Alternate Violet Sectors in Ordinary Light	208
	Fig. 138. Large Section of Amethyst Quartz in Polarised Light	208
XXVII.	Fig. 141. Cup carved out of Quartz Crystal	214
XXVIII.	Fig. 144. Dichroic "Crystal" Drops of Para-azoxy-anisol	218
	Fig. 152. Rectilinear "Liquid Prisms" of Ethyl Ester of Para-azoxy-bromocinnamic Acid	218
XXIX.	Fig. 153. "Liquid Crystals" of Dibenzal Benzidine	220
	Fig. 154. "Liquid Crystals" of Para-azoxy-anisol, showing Interference Colours under Compression	220
XXX.	Figs. 155, 156, and 157. Astatic Magnet-Systems	224
XXXI.	Fig. 158. Arrangement of Astatic Magnet-Systems in Space	226
	Fig. 161. Spherulitic Crystals of Cholesteryl Acetate	226
XXXII.	Fig. 165. The Universal Interferometer with Torsometer	236

CRYSTALS

CHAPTER I

INTRODUCTION

It is a remarkable fact that no definition of life has yet been advanced which will not apply to a crystal with as much veracity as to those obviously animate objects of the animal and vegetable world which we are accustomed to regard in the ordinary sense as "living." A crystal *grows* when surrounded by a suitable environment, capable of supporting it with its natural food, namely, its own chemical substance in the liquid or vaporous state or dissolved in a solvent. Moreover, when a crystal is broken, and then surrounded with this proper environment, it grows much more rapidly at the broken part than elsewhere, repairing the damage done in a very short space of time and soon presenting the appearance of a perfect crystal once more. In this respect it is quite comparable with animal tissue, the wonderful recuperative power of which after injury, exhibited by special growth at the injured spot, is often a source of such marvel to us. Indeed, a crystal may be broken in half, and yet each half in a relatively very brief interval will grow into a crystal as large as the original one again. The longevity and virility of the spores and seeds of the vegetable kingdom have been the themes of frequent amazement, although many of the stories told of them have been unable to stand the test of strict investigation. The virility of a crystal, however, is unchanged and permanent.

A crystal of quartz, rock-crystal, for instance—detached, during the course of the disintegration of the granitic rock of which it had originally formed an individual crystal, by the denuding influences at work in nature thousands of years ago, subsequently knocked about the world as a rounded sand grain, blown over deserts by the wind, its corners rounded off by rude contact with its fellows, and subjected to every variety of rough treatment—may eventually in our own day find itself in water containing in solution a small amount of the material of which quartz is composed,

silicon dioxide SiO_2 . No sooner is this favourable environment for continuing its crystallisation presented to it, than, however old it may be, it begins to sprout and grow again. It becomes surrounded in all probability by a beautiful coating of transparent quartz, with exterior faces inclined at the exact angles of quartz, although no sign of exterior faces had hitherto persisted through all the stages of its varied adventures. Or it may grow chiefly at two or three especially favourable places, and in the course of a few weeks, under suitable conditions, at each place a perfect little quartz crystal will radiate out from the sand grain, composed of a miniature hexagonal prism terminated by the well-known

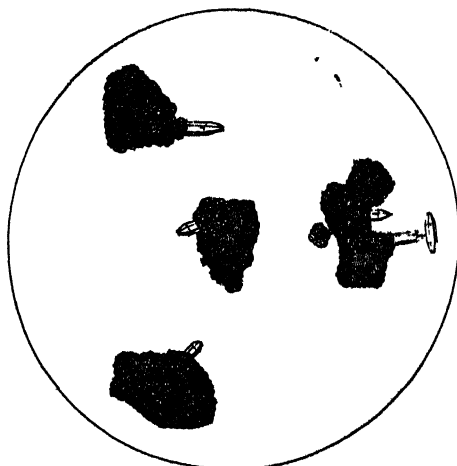

FIG. 1.—Sand Grains with Quartz Crystals growing from them.

pyramid, really consisting of a pair of trigonal (rhombohedral) pyramids more or less equally developed, and together producing an apparently hexagonal one. Four such grains of sand, from which quartz crystals are growing, are shown in Fig. 1, as they appear under a microscope magnifying about fifty diameters. One of them shows a perfectly developed doubly terminated crystal of quartz growing from the tip of a singly terminated one, attached to and growing directly out of the grain.

This marvellously everlasting power possessed by a crystal, of silent imperceptible growth, that is, of adding to its own regular structure further accretions of infinitesimal particles, the chemical molecules, of its own substance is one of the strangest functions of solid matter, and one of the fundamental facts of science which is rarely realised, compared with many of the more obvious phenomena of nature.



FIG. 2.—Monoclinic Acicular Crystals of Sulphur produced by Solidification of Liquid

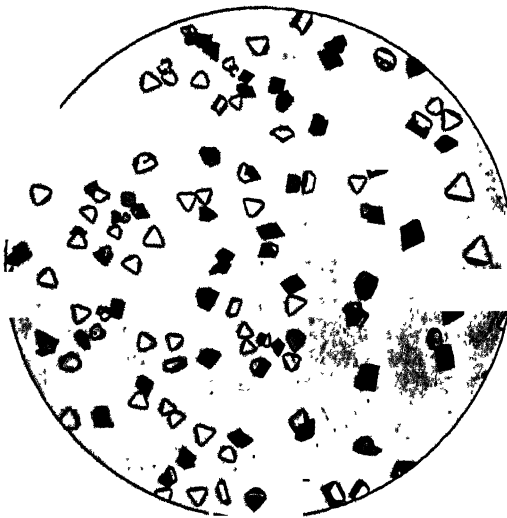

FIG. 3.—Octahedral Crystals of Arsenious Oxide produced by Condensation of Vapour

CRYSTALS FORMED BY DIFFERENT PROCESSES

A crystal in the ordinary sense of the word is solid matter in its most perfectly developed and organised form. It is composed of the chemical molecules of some definitely constituted substance, which have been laid down in orderly sequence, in accordance with a specific architectural plan peculiar to that particular chemical substance. The physical properties of the latter are such that it assumes the solid form at the ordinary temperature and pressure, leaving out of consideration for the present the remarkable viscous and liquid substances which will be specially dealt with in Chapter XVIII of this book, and which are currently known as "liquid crystals." This term is not in any case an appropriate one. For the word "crystal" should undoubtedly be left to convey the idea of rigidity of polyhedral form and internal structure, which is the very basis of crystal measurement.

The solid crystal may have been produced during the simple act of congealment from the liquid state, on the cooling of the heated liquefied substance to the ordinary temperature. Sulphur, for instance, is well known to crystallise in acicular crystals belonging to the monoclinic system under such conditions, a characteristic crop being shown in Fig. 2 (Plate I); they were formed within an earthenware crucible in which the fusion had occurred, and became revealed on pouring out the remainder of the liquid sulphur when the crystallisation had proceeded through about one-half of the original amount of the "melt."

Or the substance may be one which passes directly from the gaseous to the solid condition, on the cooling of the vapour from a temperature higher than the ordinary down to the latter, under atmospheric pressure. Oxide of arsenic, As_2O_3 , is a substance exhibiting this property characteristically, and Fig. 3 (Plate I) is a reproduction of a photograph of crystals of this substance thus produced. The white solid oxide was heated in a short test tube over a Bunsen flame, and the vapour produced was allowed to condense on a microscope glass slip, and the result examined under the microscope, using a $1\frac{1}{2}$ -inch objective. Fig. 3 represents a characteristic field of the transparent octahedral crystals thus deposited.

Or again, the crystal may have been deposited from the state of solution in a solvent, in which case it is a question of the passage of the substance from the liquid to the solid condition, complicated by the presence of the molecules of the solvent, from which the molecules of the crystallising solid have to effect their escape. Fig. 4 (Plate II) represents crystals of potash alum, for instance, growing from a drop of saturated solution on a glass slip placed on the stage of the microscope, the drop being spread within a hard ring of gold-size and under a cover glass, in order to prevent rapid evaporation and avoid apparent distortion by the curvature

of an uncovered drop. The crystals are of octahedral habit like those of oxide of arsenic, but many of them also exhibit the faces of the cube.

In any case, however it may be erected, the crystal edifice is produced by the regular accretion of molecule on molecule, like the bricks or stone blocks of the builder, and in accordance with an architectural plan more elaborate and exact than that of any human architect. This plan is that of one of the thirty-two classes into which crystals can be naturally divided with respect to their symmetry. Which specific one is developed, and its angular dimensions, are traits characteristic of the substance. The thirty-two classes of crystals may be grouped in seven distinctive systems, the seven styles of crystal architecture, each distinguished by its own minimum elements of symmetry.

A crystal possesses two further fundamental properties besides its style of architecture. The first is that it is bounded externally by plane faces, arranged on the definite geometrical plan just alluded to and mutually inclined at angles which are peculiar to the substance (unless the perfect symmetry of the cubic system be developed, for which the angles are identically determined by the symmetry itself), and which are, therefore, absolutely constant for the same temperature and pressure. The second is that a crystal is essentially a homogeneous solid, its internal structure being similar throughout, in such wise that the arrangement about any one molecule (or small group of molecules) is the same as about every other. This structure is, in fact, as regards this grosser molecular or polymolecular unit, that of one of the 14 space-lattices of Bravais, and as regards the arrangement of the atoms of which the molecule, or group of molecules, is composed, that of one of the 230 homogeneous structures ascertained by geometricians to be possible to crystals with plane faces. The first property, that of the planeness of the crystal faces, and their arrangement with geometrical symmetry, is actually determined by the second, that of specific homogeneity. For, as with human nature developed to its highest type, the external appearance is but the expression of the internal character.

When nature has been permitted to have fair play, and the crystal has been deposited under ideal conditions, the planeness of its faces is astonishingly absolute. It is fully equal to that attained by the most skilled opticians after weeks of patient labour, in the production of surfaces on glass or other materials suitable for such delicate optical experiments as interference-band production, in which a distortion equal to one wave-length of light would be fatal. Indeed, as the author once had the temerity humorously to remark in a lecture at the Royal Institution, in order to impress

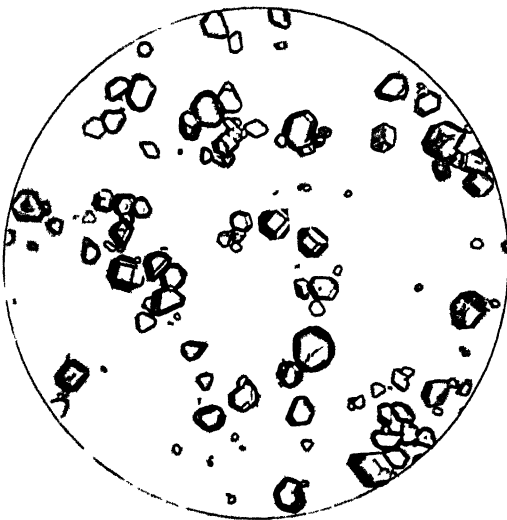

FIG. 4.—Cubic Octahedral Crystals of Potash Alum
growing from Solution

CRYSTALS FORMED BY DIFFERENT PROCESSES

To face p. 4

as strikingly as possible this wonderful fact in nature, "the beauty of crystals lies in the planeness of their faces," a statement which was further emphasized by Charivari (the author's friend, the late Mr. Walter Emanuel, who was present) in the next appearing issue of *Punch*.

In all such cases of ideal deposition, those interfacial angles on the crystal which the particular symmetry developed requires to be equal actually are so, to this same high degree of refinement, the differences with a good crystal not exceeding 2 minutes. This fact renders possible exceedingly accurate crystal measurement, that is, the determination of the angles of inclination of the faces to each other, provided refined measuring instruments (goniometers), pure chemical substances, and the means of avoiding disturbance, either material or thermal, during the deposition of the crystal, are available.

The study of crystals naturally divides itself into two more or less distinct but mutually very helpful branches, and equally intimately connected with the internal structure of crystals, namely, one which concerns their exterior configuration and the structural morphology of which it is the eloquent visible expression, and another which relates to their optical characters. For the latter are so definitely different for the different systems of crystal symmetry that they afford the greatest possible help in determining the former, and give the casting vote in all cases of doubt left after the morphological investigation with the goniometer. It is, of course, their brilliant reflection and refraction of light, with production of numerous scintillations of reflected white light and of refracted coloured spectra, which endows the hard and transparent mineral crystals, known from time immemorial as gem-stones, with their attractive beauty. Indeed, their outer natural faces are frequently, and unfortunately usually, cut away most sacrilegiously by the lapidary, in order that by grinding and polishing on them still more numerous and evenly distributed facets he may increase to the maximum the magnificent play of coloured light with which they sparkle.

An interesting and very beautiful lecture experiment was performed by the author in the lecture already referred to, delivered a few years ago at the Royal Institution, which illustrated in a striking manner this fact that the light reaching the eye from a crystal is of two kinds, namely, white light reflected from the exterior faces and coloured light which has penetrated the crystal substance and emerges refracted and dispersed as spectra. Two powerful beams of light from a pair of widely separated electric lanterns were concentrated on a cluster of magnificent large diamonds, kindly lent for the purpose by Mr. Edwin Streeter, and arranged in the shape of a crown, it being about the time of the Coronation of His late

Majesty King Edward VII. The effect was not only to produce a blaze of colour about the diamonds themselves, but also to project upon the ceiling of the lecture theatre numerous images in white light of the poles of the electric arc, derived by reflection from the facets, interspersed with equally numerous coloured spectra derived from rays which had penetrated the substance of the diamonds and had suffered both refraction and internal reflection.

CHAPTER II

THE MASKING OF SIMILARITY OF SYMMETRY AND CONSTANCY OF ANGLE BY DIFFERENCE OF HABIT, AND ITS INFLUENCE ON EARLY STUDIES OF CRYSTALS

NOTHING is more remarkable than the great variety of geometrical shapes which the crystals of the same substance, derived from different localities or produced under different conditions, are observed to display. One of the commonest of minerals, calcite, carbonate of lime, shows this feature admirably; the beautiful large rhombohedra from Iceland, illustrated in Fig. 5, or the hexagonal prisms capped by low rhombohedra from the Bigrigg mine at Egremont in Cumberland, shown in Fig. 6, appear totally different both from each other and from the "dog-tooth spar" so plentifully found all over the world, a specimen of which from the same mine is illustrated in Fig. 7. No mineral specimens could well appear more dissimilar than these represented on

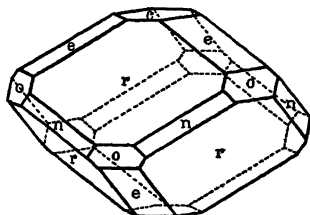

FIG. 5.—Natural Rhombohedron of Iceland Spar with Subsidiary Faces.

Plate III in Figs. 6 and 7, when seen side by side in the mineral gallery of the British Museum (Natural History) at South Kensington. But all are composed of similar chemical molecules of calcium carbonate, CaCO_3 ; and when the three kinds of crystals are investigated they are found to be identical in their crystalline system, the trigonal, and indeed further as to the subdivision or class of that system, which has come to be called the calcite class from the importance of this mineral.

Moreover, many of the same faces, that is, faces having the same relation to the symmetry, are present on all three varieties, the "forms" to which they equally belong being the common heritage of calcite wherever found. A "form" is the technical term for a set of faces having an equal value with respect to the symmetry. Thus the prismatic form in Fig. 6 is the hexagonal prism, a form which is common to the hexagonal and trigonal systems of symmetry, and the form "indices" (numbers¹ inversely proportional

¹ See page 39 for explanation of indices.

to the intercepts cut off from the crystal axes by the face typifying the form) of which are $\{2\bar{1}\bar{1}\}$; the large development of this form confers the elongated prismatic habit on the crystal. The terminations are faces of the flat rhombohedron $\{110\}$. The pyramidal form of the dog-tooth spar shown in Fig. 7 is the scalenohedron $\{20\bar{1}\}$, and it is this form which confers the tooth-like habit, so different from the hexagonal prism, upon this variety of calcite. But many specimens of dog-tooth spar, notably those from Derbyshire, consist of scalenohedra the middle portion of which is replaced by faces of the hexagonal prism $\{2\bar{1}\bar{1}\}$, and the terminations of which are replaced by the characteristic rhombohedron $\{100\}$ of Iceland spar, r in Fig. 5; indeed, it is quite common to find crystals of calcite exhibiting on the same individual all the forms which have been mentioned, that is, those dominating the three very differently appearing types. The author has himself measured such a crystal, which, besides showing all these four forms well developed, also exhibited the faces of two others of the well-known forms of calcite, an acute rhombohedron $\{3\bar{1}\bar{1}\}$ and a secondary scalenohedron $\{310\}$, and a reproduction of a drawing of it to scale is given in Fig. 8. Instead of indices the faces of each form bear a distinctive letter; $m=\{2\bar{1}\bar{1}\}$, $r=\{100\}$, $e=\{110\}$, $v=\{20\bar{1}\}$ (the faces of the scalenohedron are of somewhat small dimensions on this crystal), $n=\{3\bar{1}\bar{1}\}$, and $t=\{310\}$.

The rhombohedral form marked n on this crystal is not the same as that which is labelled n on Fig. 5, the latter being the second order hexagonal prism $\{10\bar{1}\}$. Otherwise the lettering is the same. Of the two additional forms shown on Fig. 5, c is the basal pinakoid $\{111\}$, and o is another rhombohedron $\{1\bar{1}\bar{1}\}$.

It is obviously then the "habit" which is different in the three types of calcite—Iceland spar, prismatic calc-spar, and dog-tooth spar—doubtless owing to the different local circumstances of growth of the mineral. Habit is simply the expression of the fact that a specific "form," or possibly two particular forms, is or are much more prominently developed in one variety than in another. Thus the principal rhombohedron $r=\{100\}$, parallel to the faces of which calcite cleaves so readily, is the predominating form in Iceland spar, while the scalenohedron $v=\{20\bar{1}\}$ is the habit-conferring form in dog-tooth spar. Yet on the latter the rhombohedral faces are frequently developed, blunting the sharp terminations of the scalenohedra, especially in dog-tooth spar from Derbyshire or the Hartz mountains; and on the former minute faces of the scalenohedron are often found, provided the rhombohedron consists of the natural exterior faces of the crystal and not of cleavage faces, as the cleavage of calcite is parallel to the faces of this primary rhombohedron. In the same manner the prismatic crystals from



FIG. 6.—Hexagonal Prisms of Calcite terminated by Rhombohedra



FIG. 7.—Scalenohedral Crystals of Calcite, "Dog-tooth Spar"

CRYSTALS OF CALCITE FROM THE SAME MINE, ILLUSTRATING
DIVERSITY OF HABIT

(Photographed from Specimens in the Natural History Department of the British
Museum, by kind permission.)

Egremont are characterised by two forms, the hexagonal prism $m = \{2\bar{1}\bar{1}\}$ and the secondary rhombohedron $e = \{110\}$, but both of these forms, as we have seen on the actual crystal represented in Fig. 8, are also found developed on other crystals of mixed habit.

This illustration from the naturally occurring minerals might readily be supplemented by almost any common artificial chemical preparation, sulphate of potash for instance, K_2SO_4 , the orthorhombic crystals of which take the form of elongated prisms, even needles, on the one hand, or of tabular, more or less plate-like crystals on the other hand, as shown in Fig. 90 on page 128, according as the salt crystallises by the cooling of a supersaturated solution, or by the slow evaporation of a solution which at first is not quite saturated. In both cases, and in all such cases, whether of minerals or chemical preparations, the same planes are present on the crystals of the same substance, although all may not be developed on the same individual except in a few cases of crystals particularly rich in faces; and these same planes are inclined at the same angles.

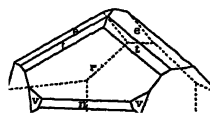

FIG. 8.—Measured Crystal of Calcite.

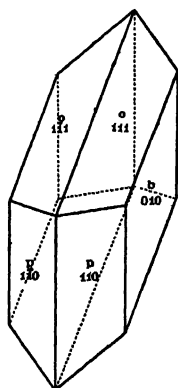

FIG. 9.—Crystal of Gypsum.

But their relative development may be so very unlike on different crystals as to confer habits so very dissimilar that the fact of the identity of the substance is entirely concealed.

A further example may perhaps be given, that of a substance, hydrated sulphate of lime, $CaSO_4 \cdot 2H_2O$, which occurs in nature as the beautiful transparent mineral gypsum or selenite—illustrated in Fig. 9, and which is found in monoclinic crystals of this shape often of very large size—and which may also be chemically prepared by adding a dilute solution of sulphuric acid to a very dilute solution of calcium chloride. The radiating groups of needles shown in Fig. 10 (Plate IV) slowly crystallised out when a drop of the mixed solution was placed on a microscope slip and examined under the microscope, using the one-inch objective. These needles, so absolutely different in appearance from a crystal of selenite, are yet similar monoclinic prisms, but in which the prismatic form is enormously elongated compared with the other (terminating) form.

This difference of facial development, rendering the crystals of

one and the same substance from different sources so very unlike each other, was apparently responsible for the very tardy discovery of the fundamental law of crystallography, the constancy of the crystal angles of the same substance. Gessner, some time between the years 1560 and 1568, went so far as to assert that not only are different crystals of the same substance of different sizes, but that also the mutual inclinations of their faces and their whole external form are dissimilar.

What was much more obvious to the early students of crystals, and which is, in fact, the most striking thing about a crystal after its regular geometric exterior shape, was the obviously homogeneous character of its internal structure. So many crystals are transparent, and so clear and limpid, that it was evident to the earliest observers that they were at least as homogeneous throughout as glass, and yet that at the same time they must be endowed with an internal structure the nature of which is the cause of both the exterior geometric regularity of form, so different from the irregular shape of a lump of glass, and of the peculiar effect on the rays of light which are transmitted through them. From the earliest ages of former civilisations the behaviour of crystals with regard to light has been known to be different for the different varieties of gemstones.

About the year 1600 Cæsalpinus observed that sugar, saltpetre, and alum, and also the sulphates of copper, zinc and iron, known then as blue, white and green vitriol respectively, separate from their solutions in characteristic forms. Had he not attributed this to the operation of an organic force, in conformity with the curious opinion of the times concerning crystals, he might have had the credit of being the pioneer of crystallographers. The first two real steps in crystallography, however, with which in our own historic times we are acquainted, were taken in the seventeenth century, within four years of each other, one from the interior structural and the other from the exterior geometrical point of view. For in 1665 Robert Hooke in this country made a study of alum, which he appears to have obtained in good crystals, although he was unacquainted with its true chemical composition. He describes in his "Micrographia" how he was able to imitate the varying habits of the octahedral forms of alum crystals by building piles of spherical musket bullets, and states that all the various figures which he observed in the many crystals which he examined could be produced from two or three arrangements of globular particles. It is clear that the homogeneous partitioning of space in a crystal structure by similar particles building up the crystal substance was in Hooke's mind, affording another testimony to the remarkably prescient insight of our great countryman.

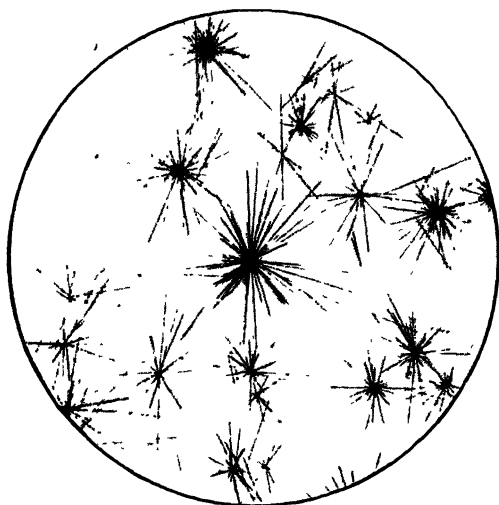

FIG. 10.—Micro-Chemical Crystals of Gypsum (Calcium Sulphate)
produced by Slow Precipitation (see p. 9)

4 CRYSTALS FORMED BY DIFFERENT PROCESSES

Four years later, in 1669, the versatile Nicolaus Steno, Professor of Anatomy at Copenhagen, Vicar Apostolic of the North, geologist, palæontologist, and crystallographer, carried out some remarkable measurements, considering the absence of proper instruments, of the angles between the corresponding faces of different specimens of rock-crystal (quartz, the naturally occurring dioxide of silicon, SiO_2 , concerning which there will be much to say later in this book), obtained from different localities, and published a dissertation—"De Solido intra Solidum naturaliter contento Dissertationis Prodromus"—(printed in 1669 in Florence, where Steno resided for a time), announcing that he found these analogous angles all precisely the same.

In the year 1688 the subject was taken up systematically by Guglielmini, and in two memoirs of this date and 1705 he extended Steno's conclusions as to the constancy of crystal angles in the case of rock-crystal into a general law of nature. Moreover, he began to speculate about the interior structure of crystals, and, like Hooke, he took alum as his text, and suggested that the ultimate particles possessed plane faces, and were, in short, miniature crystals. He further announced the constancy of the cleavage directions, so that to Guglielmini must be awarded the credit for having, at a time when experimental methods of crystallographic investigation were practically *nil*, discovered the fundamental principles of crystallography.

The fact that a perfect cleavage is exhibited by calcite had already been observed by Erasmus Bartolinus in 1670, and in his "*Experimenta Crystalli Islandici disdiaclastici*" he gives a most interesting account of the great discovery of immense clear crystals of calcite which had just been made at Eski fjördhr, in Iceland, minutely describing both their cleavage and their strong double refraction. Huyghens in 1690 followed this up by investigating some of these crystals of calcite still more closely, and elaborated his laws of double refraction as the result of his studies.

There now followed a century which was scarcely productive of any further advance at all in our real knowledge of crystals. It is true that Boyle in 1691 showed that the rapidity with which a solution cools influences the habit of the crystals which are deposited from it. But neither Boyle, with all his well-known ability, so strikingly displayed in his work on the connection between the volume of a gas and the pressure to which it is subjected, nor his lesser contemporaries, Lemery and Homberg, who produced and studied the crystals of several series of salts of the same base with different acids, appreciated the truth of the great fact discovered by Guglielmini, that the same substance always possesses the same crystalline form the angles of which are constant. Even with the

growth of chemistry in the eighteenth century, the opinion remained quite general that the crystals of the same substance differed in the magnitude of their angles as well as in the size of their faces.

We begin to perceive signs of progress again in the year 1767, when Westfeld made the interesting suggestion that calcite is built up of rhombohedral particles, the miniature faces of which correspond to the cleavage directions. This was followed by the publication in Paris in 1772 of the celebrated "Essai de Cristallographie, ou Description des Figures Géométriques, propres à différens Corps du Règne Minéral," of Romé de l'Isle, in which the law of constancy of the crystal angles of the same substance was first demonstrated.

It was succeeded in 1780 by a treatise "De formis crystallorum," by Bergmann and Gahn of Upsala, in which Guglielmini's law of the constancy of the cleavage directions was reasserted as a general one, and intimately connected with the crystal structure. It was in this year, 1780, that the contact goniometer was invented by Carangeot, assistant to Romé de l'Isle in Paris, and it at once placed at the disposal of his master a weapon of research far superior to any possessed by previous observers.

In his later enlarged work, "Crystallographie ou Description des Formes propres à tous les Corps du Règne minéral," published in Paris in 1783, Romé de l'Isle was consequently enabled to describe a very large number of naturally occurring mineral crystals, and after measuring their angles with Carangeot's goniometer he constructed models of no less than 500 different forms. Here we have work based upon sound measurement, and consequently of an altogether different and higher value than that which had gone before. It was the knowledge that his master desired faithfully to reproduce the small natural crystals which he was investigating, on the larger scale of a model, that led Carangeot to invent the contact goniometer, and thus to make the first start in the great subject of goniometry. The principle of the contact goniometer remains to-day practically as Carangeot left it, and although replaced for refined work by the reflecting goniometer, it is still useful when large mineral crystals have to be dealt with. An illustration of a duplicate of the original instrument is shown in Fig. 11, by the kindness of Sir Henry Miers. This duplicate was presented to Prof. Buckland by the Duke of Buckingham in the year 1824, and is now in the Oxford Museum. It consists of a divided semicircle of silver, hinged at the 90° graduation so that the left quadrant can be bent back out of the way when not required. The little radial arm arranged near the 140° position serves to support it when in use, a little milled-headed screw fixing it behind the arc. The outside rim of the semicircle measures 8 centimetres in diameter. The two slotted diametral bars, one of which is rotatable about the centre

of the circle, are provided with straight edges, between two of which (those forming the acute angle below, to the left) the crystal interfacial angle is to be measured by bringing each of the two faces forming the angle into perfect contact with one of the straight edges. The reading of the angle is afforded on the circle by the bevelled arm of one of the bars, in front of the arc on the upper right, which acts as indicator. The two contact straight edges are really edge-faces, the bars being about 2 mm. thick, and these edge-faces being ground true planes perpendicular to the plane of the bars and circle. The bar arranged horizontally in the figure is always at zero, the axial and right-hand pins maintaining it so, whatever the position may be along the slot. The other bar is the rotatable one. When employing the little instrument, the crystal

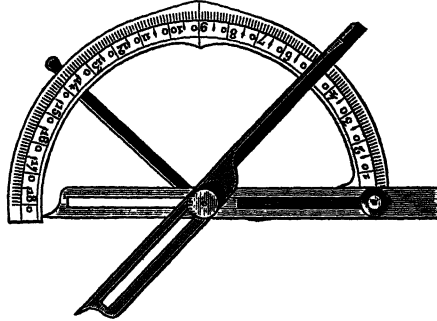

FIG. 11.—Contact Goniometer as used by Romé de l'Isle.

is first fixed by some suitable means, and then the rotatable bar is adjusted so that the two edge-faces can be laid in close contact against the two crystal faces between which the angle is to be measured, the plane of the instrument being kept perpendicular to the edge between the crystal faces. The two edge-faces are made to terminate in a point in each case, which facilitates the measurements of crystals in cavities, and the slots enable the bars to be adequately shortened to suit the size of the cavity.

From the time that measurement of an accurate description was possible by means of the contact goniometer, progress in crystallography became rapid. Romé de l'Isle laid down the sound principle, as the result of the angular measurements and the comparison of his accurate models with one another, that the various crystal shapes developed by the same substance, artificial or natural, were all intimately related, and derivable from a primitive form, characteristic of the substance. He considered that the great variety of form was due to the development of secondary faces, other than those of the primitive form. He thus connected together the work

of previous observers, consolidated the principles laid down by Guglielmini by measurements of real value, and advanced the additional suggestion of a fundamental or primitive form.

About the same time Werner was studying the principal forms of different crystals of the same substance. The idea of a fundamental form appears to have struck him also, and he showed how such a fundamental form may be modified by truncating, bevelling, and replacing its faces by other derived forms. His work, however, cannot possess the value of that of Romé de l'Isle, as it was not based on exact measurement, and most of all because Werner appears to have again admitted the fallacy that the same substance could, in the ordinary way, and not in the sense now termed polymorphism, exhibit several different fundamental forms.

But a master mind was at hand destined definitely to remove these doubts and to place the new science on a firm basis. An account of how this was achieved is well worthy of a separate chapter.

CHAPTER III

THE PRESCIENT WORK OF THE ABBÉ HAÛY

THE important work of Romé de l'Isle had paved the way for a further and still greater advance which we owe to the University of Paris, for its Professor of the Humanities, the Abbé René Just Haüy, a name ever to be regarded with veneration by crystallographers, took up the subject shortly after Romé de l'Isle, and in 1782 laid most important results before the French Academy, which were subsequently, in 1784, published in a book, under the auspices of the Academy, entitled "Essai d'une Théorie sur la Structure des Crystaux." The author happens to possess, as the gift of a kind friend, a copy of the original issue of this highly interesting and now very rare work. It contains a brief preface, dated the 26th November, 1783, signed by the Marquis de Condorcet, perpetual secretary to the Academy (who, in 1794, fell a victim to the French Revolution), to the effect that the Academy had expressed its approval and authorised the publication "under its privilege."

The volume contains six excellent plates of a large number of most careful drawings of crystals, illustrating the derivation from the simple forms, such as the cube, octahedron, dodecahedron, rhombohedron, and hexagonal prism, of the more complicated forms by the symmetrical replacement of edges and corners, together with the drawings of many structural lattices. In the text, Haüy shows clearly how all the varieties of crystal forms are constructed according to a few simple types of symmetry; for instance, that the cube, octahedron, and dodecahedron all have the same high degree of symmetry, and that the apparently very diverse forms shown by one and the same substance are all referable to one of these simple fundamental or systematic forms. Moreover, Haüy clearly states the laws which govern crystal symmetry, and practically gives us the main lines of symmetry of five of the seven systems as we now classify them, the finishing touch having been supplied in our own time by Victor von Lang, who for a time was a member of the staff of the Mineral Department of the British Museum.

Haüy further showed that difference of chemical composition was accompanied by real difference of crystalline form (except

when the crystals are cubic), and he entered deeply into chemistry, so far as it was then understood, in order to extend the scope of his observations. It must be remembered that it was only nine years before, in 1774, that Priestley had discovered oxygen, and that Lavoisier had only just (in the same year as Haüy's paper was read to the Academy, 1782) published his celebrated "Éléments de Chimie"; and further, that Lavoisier's memoir "Reflexions sur le Phlogistique" was actually published by the Academy in the same year, 1783, as that in which this book was written by Haüy. Moreover, it was also in this same year, 1783, that Cavendish discovered the compound nature of water.

Considering, therefore, all these facts, it is truly surprising that Haüy should have been able to have laid so accurately the foundations of the science of crystallography. That he undoubtedly did so, thus securing to himself for all time the term which is currently applied to him of "father of crystallography," is clearly apparent from a perusal of his book and of his subsequent memoirs.

The above only represents a small portion of Haüy's achievements. For he discovered, besides, the law of rational indices, the generalisation which is at the root of crystallographic science, limiting, as it does, the otherwise infinite number of possible crystal forms to comparatively few, which alone are found to be capable of existence as actual crystals. The essence of this law, which will be fully explained in Chapter V, is that the relative lengths intercepted along each of the three principal axes of the crystal, by the various faces other than those of the fundamental form, the faces of which are parallel to the axes, are expressed by the simplest unit integers, 1, 2, 3, or 4, the latter being rarely exceeded and then only corresponding to very small and altogether secondary faces.

This discovery impressed Haüy with the immense influence which the structure of the crystal substance exerts on the external form, and how, in fact, it determines that form. For the observations were only to be explained on the supposition that the crystal was built up of structural units, which he imagined to be miniature crystals shaped like the fundamental form, and that the faces were dependent on the step-like arrangement possible to the exterior of such an assemblage. This brought him inevitably to the intimate relation which cleavage must bear to such a structure, that it really determined the shape of, and was the expression of the nature of, the structural units. Thus, before the conception of the atomic theory by Dalton, whose first paper (read 23rd October, 1803) was published in the year 1803 in the Proceedings of the Manchester Literary and Philosophical Society, two years after the publication of Haüy's last work (his "Traité de Minéralogie," Paris, 1801), Haüy came to the conclusion that crystals were composed of units

which he termed "*Molécules Intégrantes*," each of which comprised the whole chemical compound, a sort of gross chemical molecule. Moreover, he went still further in his truly original insight, for he actually suggested that the *molécules intégrantes* were in turn composed of "*Molécules Élémentaires*," representing the simple matter of the elementary substances composing the compound, and hinted further that these elementary portions had properly orientated positions within the *molécules intégrantes*.

He thus not only nearly forestalled Dalton's atomic theory, but also our recent work on the stereometric orientation of the atoms in the molecule in a crystal structure. Dalton's full theory was not published until the year 1811, in his epoch-making book entitled "A New System of Chemical Philosophy," although his first table of atomic weights was given as an appendix to the memoir of 1803. Thus in the days when chemistry was in the making at the hands of Priestley, Lavoisier, Cavendish, and Dalton do we find that crystallography was so intimately connected with it that a crystallographer well-nigh forestalled a chemist in the first real epoch-making advance, a lesson that the two subjects should never be separated in their study, for if either the chemist or the crystallographer knows but little of what the other is doing, his work cannot possibly have the full value with which it would otherwise be endowed.

The basis of Haüy's conceptions was undoubtedly cleavage. He describes most graphically on page 10 of his "Essai" of 1784 how he was led to make the striking observation that a hexagonal prism of calcite, terminated by a pair of hexagons normal to the prism axis, similar to the prisms shown in Fig. 6 (Plate III) except that the ends were flat, showed oblique internal cleavage cracks, by enhancing which with the aid of a few judicious blows he was able to separate from the middle of the prism a kernel in the shape of a rhombohedron, the now well-known cleavage rhombohedron of calcite. He then tried what kinds of kernels he could get from dog-tooth spar (illustrated in Fig. 7) and other different forms of calcite, and he was surprised to find that they all yielded the same rhombohedral kernel. He subsequently investigated the cleavage kernels of other minerals, particularly of gypsum, fluor-spar, topaz, and garnet, and found that each mineral yielded its own particular kernel. He next imagined the kernels to become smaller and smaller, until the particles thus obtained by cleaving the mineral along its cleavage directions *ad infinitum* were the smallest possible. These miniature kernels having the full composition of the mineral he terms "*Molécules Constituentes*" in the 1784 "Essai," but in the 1801 "Traité" he calls them "*Molécules Intégrantes*" as above mentioned. He soon found that there were three distinct types of *molécules intégrantes*, tetrahedra, triangular prisms, and

parallelepipeda, and these he considered to be the crystallographic structural units.

Having thus settled what were the units of the crystal structure, Haüy adopted Romé de l'Isle's idea of a primitive form, not necessarily identical with the *molécule intégrante*, but in general a parallelepipedon formed by an association of a few *molécules intégrantes*, the parallelepipedal group being termed a "*Molécule Soustractive*." The primary faces of the crystal he then supposed to be produced by the simple regular growth or piling on of *molécules intégrantes* or *soustractives* on the primitive form. The secondary faces not parallel to the cleavage planes next attracted his attention, and these, after prolonged study, he explained by supposing that the growth upon the primitive form eventually ceased to be complete at the edges of the primary faces, and that such cessation occurred in a regular step by step manner, by the suppression

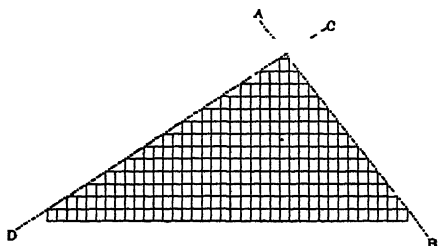

FIG. 12.

of either one, two, or sometimes three *molécules intégrantes* or *soustractives* along the edge of each layer, like a stepped pyramid, the inclination of which depends on how many bricks or stone blocks are intermitted in each layer of brickwork or masonry. Fig. 12 will

render this quite clear, the face AB being formed by single block-steps, and the face CD by two blocks being intermitted to form each step. The plane AB or CD containing the out-cropping edges of the steps would thus be the secondary plane face of the crystal, and the *molécules intégrantes* or *soustractives* (the steps can only be formed by parallelepipedal units) being infinitesimally small, the re-entrant angles of the steps would be invisible and the really furrowed surface appear as a plane one. Haüy is careful to point out, however, that the crystallising force which causes this stepped development (or lack of development) is operative from the first, for the minutest crystals show secondary faces, and often better than the larger crystals.

An instance of a mineral with tetrahedral *molécules intégrantes* Haüy gives in tourmaline, and the primitive form of tourmaline he considered to be a rhombohedron, conformably to the well-known rhombohedral cleavage of the mineral, made up of six tetrahedra. Again, hexagonal structures formed by three prismatic cleavage planes inclined at 60° are considered by him as being composed of *molécules intégrantes* of the form of 60° triangular prisms, or *molécules*

soustractives of the shape of 120° rhombic prisms, each of the latter being formed by two *molécules intégrantes* situated base to base. This will be clear from Figs. 13 and 14, the former representing the structure as made up of equilateral prismatic structural units, and the latter portraying the same structure but composed of 120° -parallelepipeda by elimination of one cleavage direction; each unit in the latter case possesses double the volume of the triangular one, and being of parallel-epipedal section is capable of producing secondary faces when arranged step-wise, whereas the triangular structure is not. The points at the intersections in these diagrams should for the present be disregarded; they will shortly be referred to for another purpose.

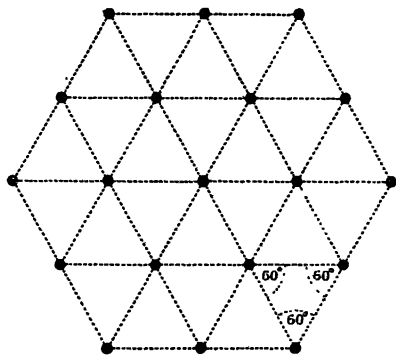

FIG. 13.

Probably the most permanent and important of Haüy's achievements was the discovery of the law of rational indices. At first this only took the form of the observation of the very limited number of rows of *molécules intégrantes* or *soustractives* suppressed. In introducing it on page 74 of his 1784 "Essai" he says: "Quoique

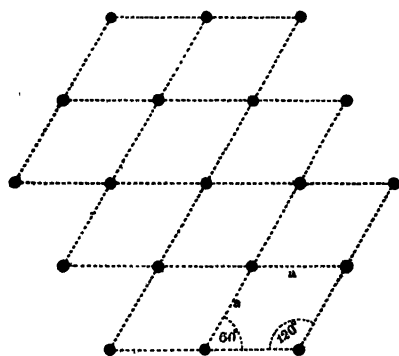

FIG. 14.

je n'ai observé jusqu'ici que des décroissemens qui se sont par des soustractions d'une ou de deux rangées de molécules, et quelquefois de trois rangées, mais très rarement, il est possible qu'il se trouve des cristaux dans lesquels il y ait quatre ou cinq rangées de molécules supprimées à chaque décroissement, et même un plus grand nombre encore. Mais ces cas me semblent devoir être plus rares, à proportion

que le nombre des rangées soustraites sera plus considérable. On conçoit donc comment le nombre des formes secondaires est nécessairement limité."

The essential difference between Haüy's views and our present ones, which will be explained in Chapter X, is that Haüy takes cleavage absolutely as his guide, and considers the particles, into

which the ultimate operation of cleavage divides a crystal, as the solid structural units of the crystal, the unit thus having the shape of at least the *molécule intégrante*. Now every crystalline substance does not develop cleavage, and others only develop it along a single plane, or along a couple of planes parallel to the same direction, that of their intersection and of the axis of the prism which two such cleavages would produce, and which prism would be of unlimited length, being unclosed.

Again, in other cases cleavage, such as the octahedral cleavage of fluor-spar, yields octahedral or tetrahedral *molécules intégrantes* which are not congruent, that is to say, do not fit closely together to fill space, as is the essence of Haüy's theory. Hence, speaking generally, partitioning by means of cleavage directions does not essentially and invariably yield identical plane-faced molecules which fit together in contact completely to fill space, although in the particular instances chosen from familiar substances by Haüy it often happens to do so. Haüy's theory is thus not adequately general, and the advance of our knowledge of crystal forms has rendered it more and more apparent that Haüy's theory was quite insufficient, and his *molécules intégrantes* and *soustractives* mere geometrical abstractions, having no actual basis in material fact; but that at the same time it gave us a most valuable indication of where to look for the true conception.

This will be developed further into our present theory of the homogeneous partitioning of space, in Chapter X. But it may be stated here, in concluding our review of the pioneer work of Haüy, that in the modern theory all consideration of the shape of the ultimate structural units is abandoned as unnecessary and misleading and that each chemical molecule, or a small group (two, three or four being common) of molecules, is considered to be represented by a point, which may be either its centre of gravity, a particular atom in the molecule or group (for we are now able in certain cases to locate the orientation of the spheres of influence of the elementary atoms in the chemical molecules), or a purely representative point standing for the molecule, or polymolecular group. The only condition is, that the points chosen within the molecules, or groups, shall be strictly analogous, and similarly orientated. The dots at the intersections of the lines in Figs. 13 and 14 are the representative points in question. We then deal with the distances between the points, the latter being regarded as molecular, or polymolecular, centres, rather than with the dimensions of the cells themselves regarded as solid entities. We thus avoid the, as yet, unsolved question of how much is matter and how much is interspace in the room between the molecular centres. When all three dimensions are considered, and not merely the two dimensions lying in the

plane of the paper in Figs. 13 and 14, we have produced the arrangement of points in space known as a space-lattice, of which we shall see in Chapter X there are 14 different kinds.

In this form the theory is in conformity with all the advances of modern physics, as well as of chemistry. And with this reservation, and after modifying his theory to this extent, one cannot but be struck with the wonderful perspicacity of Haüy, for he appears to have observed and considered almost every problem with which the crystallographer is confronted, and his laws of symmetry and of rational indices are perfectly applicable to the theory as thus modernised.

CHAPTER IV

THE SEVEN STYLES OF CRYSTAL ARCHITECTURE

It is truly curious how frequently the perfect number, seven, is endowed with exceptional importance with regard to natural phenomena. The seven orders of spectra, the seven notes of the musical octave, and the seven active chemical elements of the "period" of Mendeléeff's classification of the elements, together with the seven vertical groups to which by their periodic repetition they give rise, will at once come to mind as cases in point. This proverbial importance of the number seven is once again illustrated in regard to the systems of symmetry or styles of architecture displayed by crystals. For there are seven such systems of crystal symmetry, each distinguished by its own specific type of symmetry.

It is only within recent years that we have come to appreciate what are the real elements of symmetry. For although there are but seven systems, there are no less than thirty-two classes of crystals, and these were formerly grouped under six systems, on lines which have since proved to be purely arbitrary and not founded on any truly scientific basis. It was supposed that those classes in any system which did not exhibit all the faces possible to the system owed this lack of development to the suppression of one-half or three-quarters of the possible number, and such classes were consequently called "hemihedral" and "tetartohedral" respectively. As in the higher systems of symmetry there were usually two or more ways in which a particular proportionate suppression of faces could occur, it happened that several classes, and not merely three—holohedral (possessing the full number of faces), hemihedral, and tetartohedral—constituted each of these systems.

Thanks largely to the genius of Victor von Lang, who was formerly with us in England at the Mineral Department of the British Museum, and to his colleague there, Nevil Story Maskelyne, the Keeper of the Minerals, we have at last a much more scientific basis for our classification of crystals, and one which is in complete harmony with the now perfected theory of possible homogeneous structures. Victor von Lang showed that the true elements of symmetry are planes of symmetry and axes of symmetry. A

crystal possessing a plane of symmetry is symmetrical on both sides of that plane; that is, the halves of the crystal on the two sides of the plane are symmetrical, both as regards the number of the faces and their precise angular disposition with respect to one another, the one-half resembling the mirror-image of the other.

It is quite possible, and even the usual case, that the relative development of the faces, that is their actual sizes, may prevent the symmetry from being at first apparent; but when we come to measure the angles between the faces, by use of the reflecting goniometer, and to plot their positions out on the surface of a sphere (see Fig. 51, page 54), or on a plane representation of the latter on paper, the exceedingly useful "stereographic projection," we at once perceive the symmetry perfectly plainly.

Thus in Fig. 15 is represented a measured crystal of the salt potassium nickel sulphate, $K_2Ni(SO_4)_2 \cdot 6H_2O$, belonging to the monoclinic system of symmetry, and which, therefore, possesses only one plane of symmetry, which is parallel to the face *b*. In Fig. 16 its stereographic projection is shown, in which each face in one of the symmetrical right and left halves is represented by a dot; the plane of symmetry parallel to the face *b* is arranged in this projection to be the plane of the paper, so that

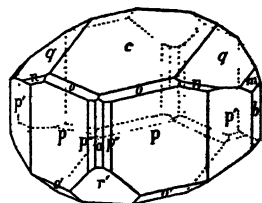

FIG. 15.—Measured Crystal of Potassium Nickel Sulphate.

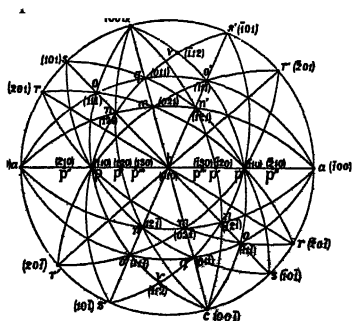

FIG. 16.—Stereographic Projection of Potassium Nickel Sulphate and its Isomorphous Analogues.

really represents two symmetrical faces, one above and one below the paper, while the circumferential dots represent faces perpendicular to the symmetry plane and paper. The mode of arriving at such a useful projection, or plan of the faces, will be discussed more fully later in Chapter VII. But for the present purpose it will be sufficient to note that the right and left halves of the crystal shown in Fig. 15 are obviously symmetrical to each other, and that the plan of either half, projected on the dividing plane of symmetry itself, may be taken as given in Fig. 16; that is, we may imagine the crystal shown in Fig. 15 to be equally divided by a section plane which is vertical and perpendicular to the paper when the latter is held up behind the crystal and in front of the eye, this section plane being the

plane of symmetry and parallel to the face $b=(010)$.¹ It may thus be imagined as the plane of projection of Fig. 16.

An axis of symmetry is a direction in the crystal such that when the latter is rotated for an angle of 60° , 90° , 120° , or 180° around it, the crystal is brought to look exactly as it did before such rotation. When a rotation for 180° is necessary in order to reproduce the original appearance, the axis is called a "digonal" axis of symmetry, for two such rotations then complete the circle and bring the crystal back to identity, not merely to similarity. When the rotation into a position of similarity is for 120° , three such rotations are required to restore identity, and the axis is then termed a "trigonal" one. Similarly, four rotations to positions of similarity 90° apart are essential to complete the restoration to identity, and the axis is then a "tetragonal" one, each rotation of a right angle causing the crystal to appear as at first, assuming, as

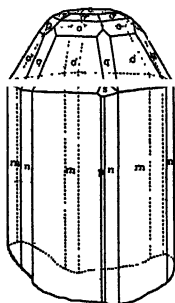

FIG. 17—Measured Crystal of Apatite.

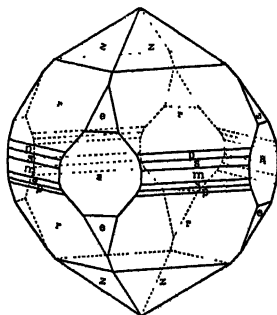

FIG. 18—Measured Crystal of Anatase.

in all cases, the ideal equality of development of faces. Lastly, if 60° of rotation bring about similarity, six such rotations are required in order to effect identity of position, and the axis is known as a "hexagonal" one.

Now, there is one system of symmetry which is characterised by the presence of a single hexagonal axis of symmetry, and this is the *hexagonal system*. A crystal of this system, one of the naturally occurring mineral apatite, which has been actually measured by the author, is shown in Fig. 17. There is another system, the chief property of which is to possess a tetragonal axis of symmetry, and which is therefore termed the *tetragonal system*. A tetragonal crystal of anatase, titanium dioxide, TiO_2 , which has likewise been measured on the goniometer by the author, is shown in Fig. 18. And there is yet another system, the trigonal, the chief attribute of which is the possession of a single trigonal axis of symmetry, and

¹ The meaning of crystal indices will be found to be explained in Chapter V.

which is consequently named the *trigonal system*. In Fig. 19 is shown a crystal of calcite, within which the directions of the three rhombohedral crystallographic axes of the trigonal system, and that of the vertical trigonal axis of symmetry, are indicated in broken-and-dotted lines.

But there is one system of symmetry, the highest possible, and which has already been referred to as the *cubic system*, which combines in itself all but one (the hexagonal axis) of the elements of symmetry. Indeed, not only does it possess a tetragonal, a trigonal, and a digonal axis of symmetry, but also ten other symmetry axes; for these three automatically involve altogether the presence of no less than three tetragonal, four trigonal, and six digonal axes of symmetry, together with nine planes of symmetry, twenty-two elements of symmetry being thus present in all.

The perfections of the cube, the simple lines of which are illustrated in Fig. 20, as the expression of the highest kind of symmetry,

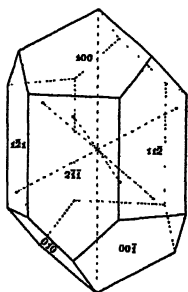

FIG. 19.—Crystal of Calcite.

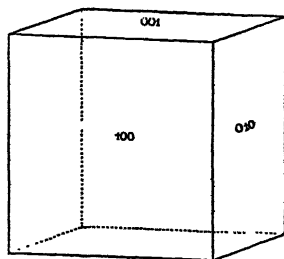

FIG. 20.—The Cube.

with angles all right angles and sides and edges all equal, were so fully appreciated by the geometrical minds of the ancient Greek philosophers, imbued with the innate love of symmetry characteristic of their nation, that to them the cube became the emblem of perfection. We are reminded of this interesting fact in the Book of Revelation, which, in describing in its inimitable language the wonders of the Holy City, speaks of it as "lying foursquare," and attributes to it the properties of the cube, that "The length and the breadth and the height of it are equal."

The full symmetry of the cubic system is not realised, however, by a study of the cube alone; we only appreciate it when we come to examine the general form of the cubic system, that which is produced by starting with a face oblique to all three axes, and with different amounts of obliquity to each, and seeing how many repetitions of the face the symmetry demands. The presence of such a face involves as a matter of fact, when all the elements of

symmetry are satisfied, the presence also of no less than forty-seven others, symmetrically situated, the forty-eight-sided figure produced being the hexakis octahedron shown in Fig. 21, and which is occasionally actually found developed in nature as the diamond. All diamonds do not by any means exhibit this form so wonderfully rich in faces, but diamonds are from time to time found which do show all the forty-eight faces well developed.

Besides these four more highly symmetrical systems or styles of crystal architecture, a fifth, the *monoclinic system*, characterised by a single plane of symmetry and one axis of digonal symmetry perpendicular thereto, has already been alluded to, and a typical crystal illustrated in Fig. 15. A sixth, the *rhombic system*, perhaps in some ways the most interesting of all, and certainly so optically, possesses three rectangular axes of symmetry, identical in direction with the crystallographic axes, and three mutually rectangular

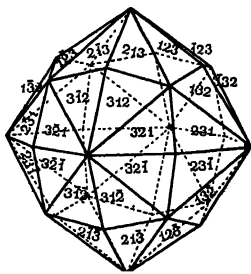

FIG. 21.—The Hexakis Octahedron.

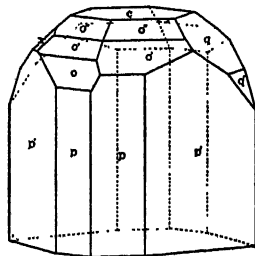

FIG. 22.—Measured Crystal of Topaz.

planes of symmetry, coincident with the axial planes and intersecting each other in the axes. The lengths of the three crystal axes are unequal, however, and herein lies the essential difference from the cube, the three rectangular axes of which (parallel to the cube edges) are all equal. A very typical rhombic substance is topaz, a crystal of which, about three millimetres in diameter, is shown very much enlarged in Fig. 22. Every face on this crystal has been actually investigated on the goniometer, and the interfacial angles measured.

Lastly, there is the seventh, the *trichlinic system*, in which there are neither planes nor axes of symmetry, but, even in its holohedral class, only symmetry about the centre, each face having a parallel fellow. Sulphate of copper, blue vitriol, $\text{CuSO}_4 \cdot 5\text{H}_2\text{O}$, shows this type of symmetry, or rather lack of it, very characteristically, and a crystal of this beautiful deep blue salt, measured by the author, is represented in Fig. 23.

Hence, we have arrived logically at seven systems of symmetry

or styles of crystal architecture, distinguished by the nature of their essential axes of symmetry, and the planes of symmetry which may accompany them. Now the full degree of symmetry of each system may be reduced to a certain minimum without lowering the system, the type of symmetry and the arrangement of crystal axes being the same in all the classes of the system; for in all the systems but the triclinic there are several definite stages of reduction before the minimum is reached, each stage corresponding to one of the thirty-two classes of crystals. Thus in the cubic system there are four classes besides the holohedral, in the tetragonal six, in the hexagonal four, in the trigonal six, in the rhombic and monoclinic two each, and in the triclinic one. In order not to render this book too technical for general readers, it is not desirable to give details here as to the precise elements of symmetry present in each of the 25 classes other than the 7 holohedral classes. But a concise statement, for the whole of the 32 classes, will be found at the close of the book in Appendix II.

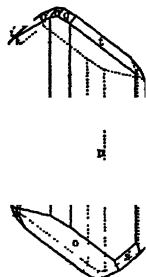

FIG. 23.—Measured Crystal of Copper Sulphate.

We have thus attained at length to a truly scientific classification of crystal forms, by using axes and planes of symmetry as *criteria*. There is no occasion whatever to imagine suppression of faces in the classes of lower than the holohedral or highest symmetry of any system. In these classes it is simply the fact that less than the full number of elements of symmetry possible to the system are present and characterise the class, which still conforms, however, to the minimum symmetry absolutely essential to the system.

The drawings of crystals of the seven systems in the foregoing illustrations will have given a correct idea of the nature of the symmetry in each case. But now it may be much more interesting to present a series of reproductions of photographs of some actual crystals of the different systems. Such a series is given in Figs. 24 to 33, Plates V to IX. They were taken with the aid of the microscope, the substances being crystallised from a slightly super-saturated (metastable, see page 45) solution in each case, on a microscope-slip. A ring of gold-size was first laid on the slip, and allowed to dry for several days. The drop of solution, in the metastable super-saturated condition (corresponding to the region of solubility which lies between the solubility and super-solubility curves, Fig. 47, page 44), was placed in the middle of the ring, and crystallisation just allowed to start, either owing to evaporation and consequent production of the labile (see page 45) condition for spontaneous crystallisation, or by access of a germ crystal from the air. It was then covered with a cover-glass, which had the desired

effect of enclosing the solution in a thin parallel-sided cell, a film of the thickness of thick paper, suitable for undistorted microscopic observation and photomicrography, and also the effect of arresting evaporation and therefore the rapidity of the growth of the crystals, so that a photomicrograph taken with the minimum necessary exposure was quite sharp.

The crystals shown in the accompanying photographic reproductions, Figs. 24 to 33 (Plates V to IX), as well as Fig. 4 (Plate II), already described, were thus photographed in the very act of slow growth, employing a one-inch objective very much stopped down. Such photographs are infinitely sharper and more beautifully and delicately shaded than those taken of dry crystals.

Fig. 24, Plate V, represents cubic octahedra of the double cyanide of potassium and cadmium, $2\text{KCN}\cdot\text{Cd}(\text{CN})_2$, a salt which crystallises out in relatively large and wonderfully transparent and well-formed single octahedra on a micro-slip, and is particularly suitable for demonstrating the character of this highest system, the cubic, of crystal symmetry. Special development of the pair of faces of the octahedron parallel to the glass surfaces has occurred, owing to greater freedom of growth at the boundaries of these faces, as is usual in such circumstances of deposition, but the other pairs of faces are quite large enough to show their nature clearly.

Fig. 25, on the same Plate V, shows a slide of cæsium alum, $\text{C}_2\text{sSO}_4\cdot\text{Al}_2(\text{SO}_4)_3\cdot 24\text{H}_2\text{O}$, in which the octahedra are smaller, and some of them, notably one in the centre of the field, are perfectly proportioned.

Fig. 26, Plate VI, represents octahedra of ammonium iron alum (formula like that of cæsium alum, but with NH_4 replacing Cs and Fe replacing Al) crystallising on a hair. It illustrates the interesting manner in which crystallisation will sometimes occur, under conditions of quietude, when some object or other on which the crystals can readily deposit themselves is present or introduced, such as a silk or cotton thread, or a hair as in this case.

Fig. 27, on the same Plate VI, represents tetragonal crystals of potassium ferrocyanide, $\text{K}_4\text{Fe}(\text{CN})_6$, composed of tabular crystals parallel to the basal pinakoid, bounded by faces of one order, first or second, of tetragonal prism (according as the faces are at 45° to the vertical rectangular axial planes or are parallel to them), the corners being modified at 45° by smaller faces of the other order of tetragonal prism.

Fig. 28, Plate VII, is a photograph of large rhombic crystals of hydrogen potassium tartrate, $\text{HKC}_4\text{H}_4\text{O}_6$, obtained by addition of tartaric acid to a dilute solution of potassium chloride. They are rectangular rhombic prisms capped by pyramidal forms, and also modified by other prismatic and domal forms.

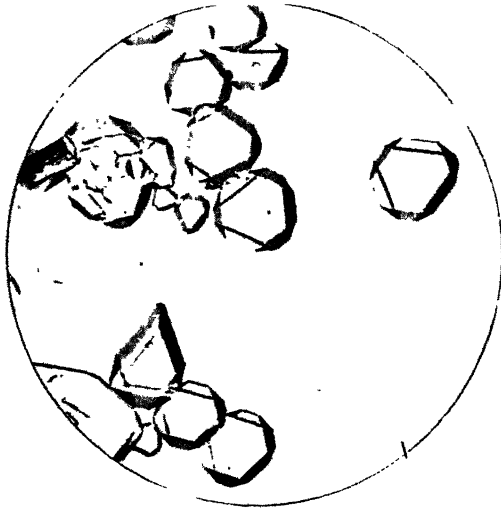

FIG. 24.—Octahedra of Potassium Cadmium Cyanide

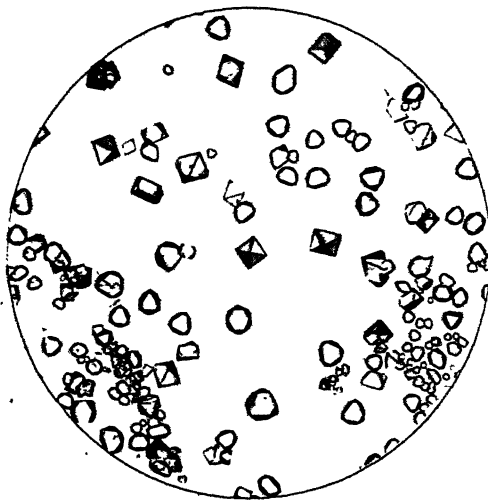

FIG. 25.—Octahedra of Cæsium Alum
CUBIC CRYSTALS GROWING FROM SOLUTION

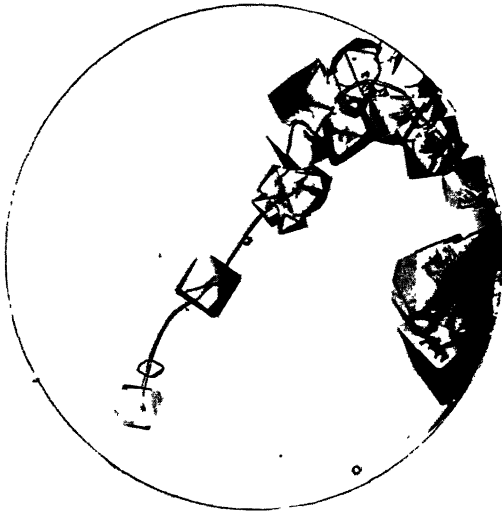

FIG. 26.—Octahedra of Ammonium Iron Alum crystallising on a Hair



FIG. 27.—Tetragonal Crystals of Potassium Ferrocyanide

CRYSTALS GROWING FROM SOLUTION

To follow Plate V

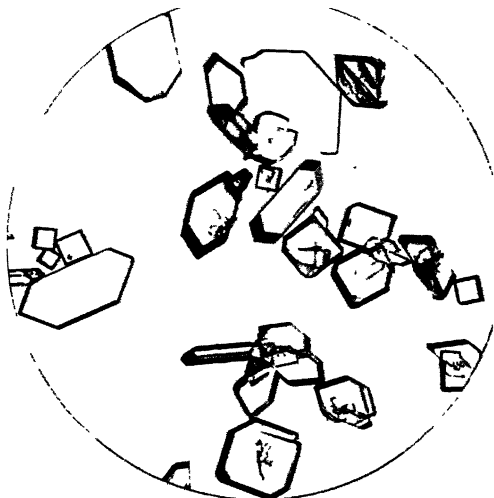

FIG. 28.—Rhombic Crystals of Potassium Hydrogen Tartrate



FIG. 29.—Rhombic Crystals of Ammonium Magnesium Phosphate, showing Special Growth along Line of Scratch

RHOMBIC CRYSTALS GROWING BY SLOW PRECIPITATION

To follow Plate VI

Fig. 29, also on Plate VII, represents another rhombic substance, ammonium magnesium phosphate, $\text{NH}_4\text{MgPO}_4 \cdot 6\text{H}_2\text{O}$, which occurs naturally as the mineral struvite, but here obtained by very slow precipitation of a dilute solution of magnesium sulphate containing ammonium chloride and ammonia with hydrogen disodium phosphate. It illustrates in an interesting manner how, when a saturated solution is kept quiet, and then the surface of the vessel containing it is scratched by a needle-point, a line of small crystals at once starts forming along the line of scratch, even although the latter has made no actual impression on the glass itself. Such a line of crystals will be observed running across the middle of the slide. The crystals are very similar to those of the mineral struvite, the same facial planes being developed.

Fig. 30, Plate VIII, shows a monoclinic substance, ammonium magnesium sulphate $(\text{NH}_4)_2\text{Mg}(\text{SO}_4)_2 \cdot 6\text{H}_2\text{O}$, which crystallises out splendidly on a micro-slip. The field includes several very well-formed typical crystals of the salt, which is one of the same exceedingly important isomorphous series to which potassium nickel sulphate, Fig. 15, belongs; it is obtained by mixing solutions containing molecularly equivalent quantities of ammonium and magnesium sulphates. The primary monoclinic prism is the chief form, terminated by clinodome faces and smaller strip-faces of the basal plane, the latter, however, being occasionally the chief end form. Small pyramid faces are also seen here and there modifying the solid angles.

Another beautifully crystallising monoclinic substance is shown in the next slide, Fig. 31, on the same Plate VIII, namely, potassium sodium carbonate, $\text{KNaCO}_3 \cdot 6\text{H}_2\text{O}$, obtained from a solution of molecular proportions of potassium and sodium carbonates. Numerous forms of the monoclinic system are developed, on relatively large and perfectly transparent and delicately shaded individuals.

A triclinic substance is represented in Fig. 32, Plate IX, potassium ferricyanide, $\text{K}_3\text{Fe}_2(\text{CN})_{12}$. The triply oblique nature of the symmetry is clearly exhibited by this salt, the absence of any right angles being very marked.

Fig. 33, also on Plate IX, illustrates more particularly a class of one of the systems, the cubic, which is of lower than holohedral (full) systematic symmetry. This is the case also with hydrogen potassium tartrate and ammonium magnesium phosphate, but the forms shown of those salts on the slides represented in Figs. 28 and 29 are chiefly those which are also common to the holohedral classes of their respective systems, and the lower class symmetry is not emphasised. But here in Fig. 33, representing Schlippe's salt, sodium sulphantimoniate, $\text{Na}_3\text{SbS}_4 \cdot 9\text{H}_2\text{O}$, we have very clear

development of the tetrahedron, belonging to the lowest of the five classes (class 28) of the cubic system. The crystals are almost all combinations of two complementary tetrahedra, one of which is developed so very much more than the other that the faces of the latter only appear as minute replacements at the corners of the predominating tetrahedron.

This is the last for the present of these fascinating growths of crystals under the microscope, but three more will be given subsequently, in Figs. 48 and 49, on Plate XII, and Fig. 50, Plate XIII, to illustrate crystallisation from metastable and labile solutions.

Fig. 34, Plate X, represents another kind of phenomenon, equally instructive. It shows a field in a crystal of quartz, as seen under the same power of the microscope, a one-inch objective with small stop and an ordinary low-power eyepiece. Just above and to the left of the centre of the field is a cavity, the shape of which is remarkable, for it is that of a quartz crystal, a hexagonal prism terminated by rhombohedral faces. The cavity is filled with a saturated solution of salt, except for a bubble of water vapour, and a beautiful little cube of sodium chloride which has crystallised out from the solution. This slide, therefore, gives us an example of a natural cubic crystal, and also an indication of the shape of quartz crystals, the cavity itself being a kind of negative quartz crystal. The crystal in which it occurs must have been formed very deep down in a reservoir of molten material beneath a volcano, under the great pressure of superincumbent rock masses. It was probably one of the quartz crystals of a granite rock which had crystallised under these conditions. Almost every crystal of quartz found in such granite rocks displays thousands of small cavities filled with liquid and a bubble, although it is very rare to find one with so good a cube of salt and having the configuration of a quartz crystal for the shape of the cavity. Many such cavities, however, contain as the liquid compressed carbonic acid (really the anhydride of the acid, carbon dioxide, CO_2), the very fact of the carbon dioxide being in the liquefied state affording ample evidence of the pressure under which the crystal was formed. The proof that the liquid is carbon dioxide in these cases is afforded by the fact that when the crystal is warmed to 32°C ., the critical temperature of carbon dioxide, at which it can no longer remain liquid, but must become a gas, the bubble disappears and the cavity becomes filled with gas. Carbonic acid cavities are readily recognised, inasmuch as the bubble is extremely mobile, and is normally in a state of movement on the very slightest provocation.

The liquid cavity in the remarkable quartz crystal illustrated in Fig. 34, and the bubble of vapour formed on cooling, and consequent contraction of the liquid more than the solid quartz (the thermal

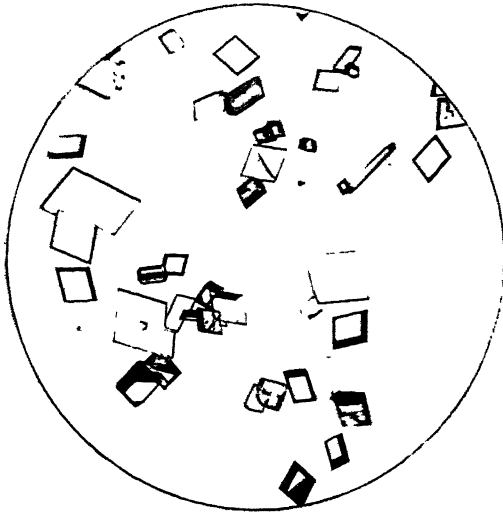

FIG. 32.—Triclinic Crystals of Potassium Ferricyanide



FIG. 33.—Tetrahedral Crystals of Sodium Sulphantimoniate,
Cubic Class 28

CRYSTALS GROWING FROM SOLUTION

To follow Plate VIII

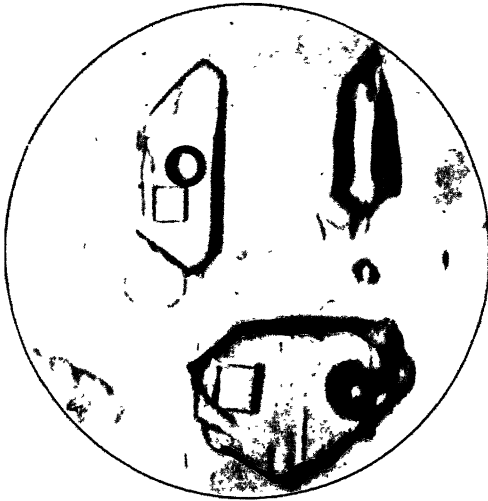

FIG. 34.—Liquid Cavities in Quartz Crystal (Trigonal), containing Saturated Solution and Cubic Crystals of Sodium Chloride

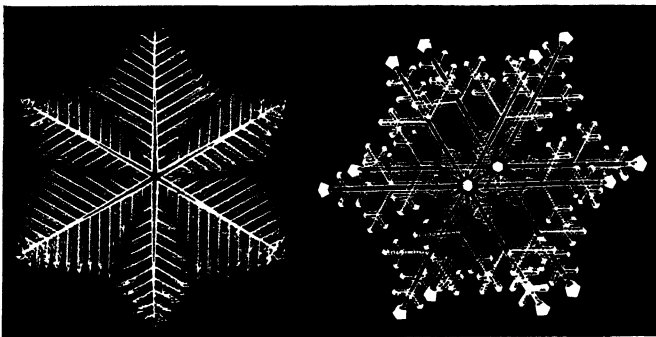

FIG. 36 —Two characteristic Forms of Snow Crystals (Hexagonal)

To follow Plate IX

dilatation of liquids being usually greater than that of solids) when it was no longer able to fill the cavity, remind one of the beautiful water flowers formed for the contrary reason in ice on passing a beam of light through a slab, owing to the warming effect of the accompanying heat rays. Water was formerly considered to crystallise like quartz, in the trigonal system, its normal forms being the hexagonal prism and bipyramid, these forms being common to both the trigonal and hexagonal systems. According to more recent investigation, however, by Rinne, St. John, Dennison, and Sir William Bragg (by means of X-rays), it is really hexagonal, but is built up of four interpenetrating trigonal, triangular prism, space-lattices.

A slab of lake ice is generally a huge crystal plate perpendicular to the trigonal axis, or in the case of disturbed growth an interlacing mass of such crystals, all perpendicular to the optic axis (see page 182), the axis of the hexagonal prism and of trigonal or hexagonal symmetry. When the heat rays from the lantern pass through such a slab of ice, the surface of which is focussed on the screen by a projecting lens, they cause the ice to begin to melt in numerous spots in the interior of the slab simultaneously; and the structure of the crystal is revealed by the operation occurring with production of cavities taking the shape

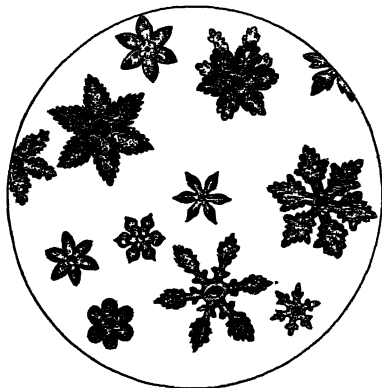

FIG. 35.—Negative Ice Crystals, or "Water Flowers," in Ice.

of hexagonal stars, which when focussed appear on the screen as shown in Fig. 35. They are filled with water except for a bubble (vacuole), which contains only water vapour. For the liquid water occupies less room than did the ice from which it was produced, owing to the well-known fact that water expands on freezing. This abnormal expansion with cooling begins at the temperature of the maximum density of water, 4°C ., and proceeds steadily until the freezing point 0° is reached, when, at the moment of crystallisation, the mass suddenly increases in volume by as much as 10 per cent. This expansive leap when the molecules of water marshal themselves into the organised order of the homogeneous structure, that of the space-lattice of the trigonal prism, is one of the most remarkable phenomena in nature, and its exceptional character, so contrary to the usual contraction

on solidification of a liquid, is of vital moment to aquatic life. For the layer of ice formed, being lighter than water, floats on the surface of the latter, and thus forms a protective layer and prevents to a large extent further freezing, except as a slow thickening of the layer, the total freezing of the water of a lake or river being rendered practically impossible, an obvious provision for the security of life of the piscatorial and other inhabitants of the waters.

Hence, as the molecules of the substance H_2O are one by one detached from their solid assemblage as ice, and become more loosely associated as the less voluminous liquid water, they cannot occupy the whole of the cavity formed in the solid ice, and a small vacuous space, occupied only by water vapour at its ordinary low tension corresponding to the low temperature, is formed and appears as the bubble. Moreover, the cavity itself takes the shape of a hexagonal star-shaped flower, the bubble showing at its centre, the cavity being thus a kind of negative ice crystal, like the negative quartz crystal shown in Fig. 34. Apparently in the production of these cavities, just as in the production of the well-known etched figures on crystal faces by the application of a minute quantity of a solvent for the crystal substance, the crystal edifice is taken down, molecule by molecule, in a regular manner, resulting in the formation of a cavity showing the symmetry of the regular point-system which is present in the crystal structure. The crystal structure of ice has been shown by Sir William Bragg to be an exceptionally open one, which quite accounts for the closer packing of the molecules of H_2O on resuming the liquid state as water.

The water flowers of Fig. 35 remind one very much of snow crystals, two of which, re-engraved from the wonderfully careful drawings of the late Mr. Glaisher, are represented in Fig. 36, Plate X. They all exhibit the symmetry of the hexagonal prism, which is equally a form of the trigonal system as it is of the hexagonal system. The snow crystals, being formed from water vapour condensed in the cold upper layers of the atmosphere, appear more or less as skeleton crystals, owing to the rarity of the semi-gaseous material condensed, compared with the extent of the space in which the crystallisation occurs. Indeed the exquisite tracery of these snow crystals appears to afford a visual proof of the existence of the trigonal-hexagonal space-lattice as the framework of the crystal structure of ice. When one considers the countless numbers of such beautiful gems of nature's handiwork massed together on an extensive snow-field of the higher Alps—such as that of the Piz Palü in the Upper Engadine, shown in the photograph (taken shortly after sunrise) reproduced in Fig. 37, Plate XI, as seen from the Diavolezza Pass—produced in the pure air of the higher regions of the atmosphere, and frequently seen by the early morning

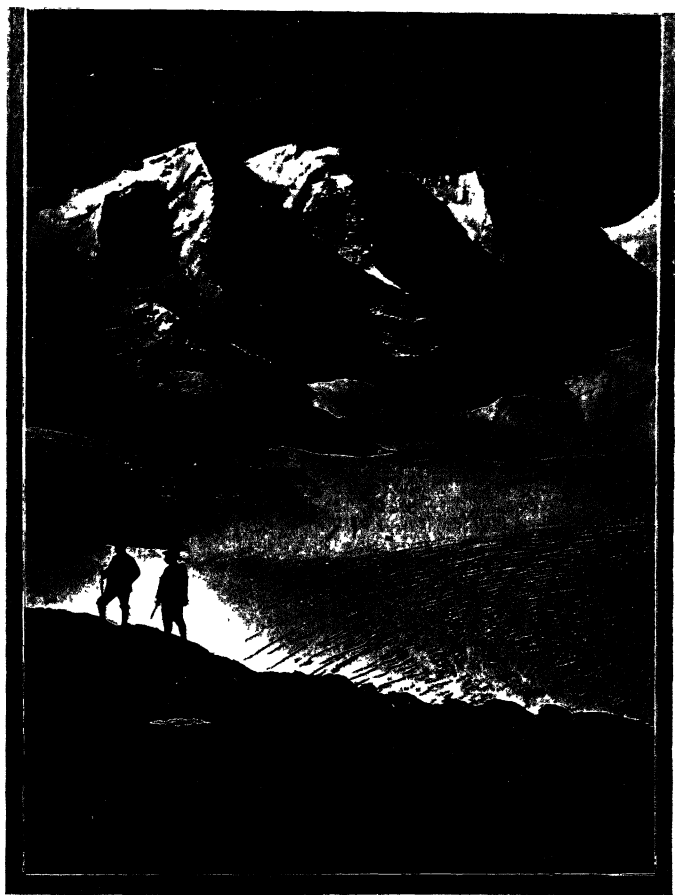

FIG. 37.—Piz Palü and Snow-field of the Pers Glacier,
from the Diavolezza Pass, Upper Engadine

(From a photograph by the author.)

climber lying uninjured in all their beauty on the surface of the snow-field, one is lost in amazement at the prodigality displayed in the broadcast distribution of such peerless gems.

On the occasion of the author's ascent of Mont Blanc, on a magnificently fine, sunny and cloudless day in early August, 1923, a fierce north wind of exceedingly low temperature was quite suddenly encountered when the party (two guides and the author) were still about an hour's climb from the summit, which was reached at 7.45 a.m., the start from the sleeping place on the Grands Mulets having been made by starlight at one o'clock. The passage of the final snow arêtes leading to the summit—two of which are very sharp, with a steep snowfield seamed with crevasses on either side—was rendered somewhat precarious in such a wind; and as these snowfields, at a height of fifteen thousand feet, were covered more or less loosely with a carpet of just such exquisite snow crystals as have been described, the wind was thickly charged with both whole and broken crystals, bombarding the climbers with a blast of ice needles, the detached pointed rays of hexagonal stars, often barbed by their frond-like branches, an experience no less unpleasant than interesting. About a quarter of an hour before reaching the top the crystal blast as suddenly ceased, but the wind was encountered again, between the same levels, in descending. On the summit, a small dome of pure white snow, the crown of which is the highest point of Europe, 15,782 feet above sea-level, all was quiescent, and the view superbly clear in all directions, the whole of the snow-clad Alps of Switzerland, of French Savoy and Dauphiny, and of Italy, as well as the Jura and the Apennines, being included in this matchless vision.

CHAPTER V

HOW CRYSTALS ARE DESCRIBED. THE SIMPLE LAW LIMITING THE NUMBER OF POSSIBLE FORMS

THE most wonderful of all the laws relating to crystals is the one already briefly referred to which limits and regulates the possible positions of faces, within the lines of symmetry which have been indicated in the last chapter. Having laid down the rules of symmetry, it might be thought that any planes which obey these laws, as regards their mode of repetition about the planes and axes of symmetry, would be possible. But as a matter of fact this is not so, only a very few planes inclined at certain definite angles, repeated in accordance with the symmetry, being ever found actually developed. The reason for this is of far-reaching importance, for it reveals to us the certainty that a crystal is a homogeneous structure composed of definite structural units of tangible size, which are either the chemical molecules, or small groups of molecules, built up on the plan of one of the fourteen space-lattices made known to us by Bravais, and to be referred to more fully in Chapter X. In order to render this fundamental law comprehensible, it will be essential to explain in a few simple words how the crystallographer identifies and labels the numerous faces on a crystal, in short, how he describes a crystal, in a manner which shall be understood immediately by everybody who has studied the very simple rules of the convention.

It is a matter of common knowledge that the mathematical geometrician defines the position of any point in space with reference to three planes, which in the simplest case are all mutually at right angles to each other like the faces of a cube, and which intersect in three rectangular axes, a , b , c , the third c being the vertical axis, b the lateral one, and a the front-and-back axis. The distances of the point from the three reference planes, as measured by the lengths of the three lines drawn from the point to the planes parallel to the three axes of intersection, at once gives him what he calls the "co-ordinates" of the point, which absolutely define its position. In the same way we can imagine three axes drawn within the crystal, by which not only the position of any point on any face of the crystal may be located, but which may be used more

simply still to fix the position of the face itself. The directions chosen as those of the three axes are the edges of intersection of three of the best developed faces.

If there were three such faces inclined at right angles they would be chosen in preference to all others, as they would certainly prove to be faces of prime significance as regards the symmetry of the crystal. When there are no such rectangularly inclined faces developed on the crystal, then the three best developed faces nearest to 90° to each other are chosen, the two factors of nearness to rectangularity and excellence of development being simultaneously borne in mind in making the choice of axial planes, and discretion used.

If the crystal belong to the cubic, tetragonal, or rhombic systems, for instance, three faces meeting each other rectangularly are possible planes on the crystal, and will very frequently be found actually developed; such would obviously be chosen as the axial

o^o

FIG. 38.—The Cube and its Three Equal Rectangular Axes.

FIG. 39.—Tetragonal Prism and its Three Rectangular Axes.

planes. The edges of the cube, or of the tetragonal or rectangular rhombic prism, will be the directions of the crystallographic axes in this case, and we can imagine them moved parallel to themselves until the common centre of intersection, the "origin" of the analytical geometrician, will occupy the centre of the crystal, and the faces of the latter be built up symmetrically about it. When the crystal is cubic, the three rectangular axes will be of equal length, as shown in Fig. 38; if tetragonal, the two horizontal axes will be equal, but will differ in length from the vertical axis, as represented in Fig. 39. If the crystal be rhombic, all three axes will be of different lengths, as indicated in Fig. 40, which represents the axes and axial planes of an actual rhombic substance, topaz, for which the lateral axis b and vertical axis c are nearly but not quite equal, while the front-and-back axis a is very different.

When the crystal is of monoclinic symmetry, as in Fig. 41, three axes will similarly be found as the intersection of three principal parallel pairs of faces, but two of them will be inclined at an angle

other than 90° to each other, while the third, the lateral one in Fig. 41, will be at right angles to those first two and to the plane containing them; moreover, all three are unequal in length. In the case of a triclinic crystal, shown in Fig. 42, however, there can be no right angles, and the intersections of three important faces meeting each other at angles as near 90° as possible are chosen as the axes, regard being had to both factors of approximation to rectangularity and importance of development. These triclinic axes are the most general type of crystal axes, for not only are the angles not right angles, but the lengths of the axes are also unequal.

The cases of the hexagonal and trigonal systems are somewhat special. The hexagonal has four such axes, as represented in Fig. 43, the lines of intersection of the faces of the hexagonal prism closed by a pair of perpendicular terminal planes, namely, one vertical axis parallel to the vertical edges, and three horizontal axes inclined at 120° to each other, and parallel to the pair of basal plane faces, equal to each other in length, but different from the length of the vertical axis. The hexagonal axial-plane prism shown in Fig. 43 is known as one of the first order. The hexagonal prism corresponding to the tetragonal one of Fig. 39, in which the axes emerge in the centres of the faces, is said to be of the second order, and is shown in Fig. 44. The trigonal system of crystals is best described with reference to three equal but not rectangular axes, parallel to the faces of the rhombohedron, one of the principal forms of the system, so well seen in Iceland spar, and illustrated in Fig. 45. The rhombohedron may be regarded as a cube resting on one of its corners (solid angles), with the diagonal line joining this to the opposite corner vertical, the cube being then deformed by flattening or elongating it along the direction of this diagonal. The edges meeting at the ends of this vertical diagonal are then the directions of the three trigonal crystallographic axes.

In this last illustration the vertical direction of the altered diagonal is that of the trigonal axis of symmetry, for the rhombohedron is brought into apparent coincidence with itself again if rotated for 120° round this direction. But although a symmetry axis, this is not a crystallographic axis of reference. It is not shown in Fig. 45, therefore, but is given in Fig. 19 on page 25. On the other hand, the singular vertical axis of reference of the tetragonal and hexagonal systems is identical with the tetragonal or hexagonal axis of symmetry of these systems, and the three crystallographic axes of reference of the cube are identical with the three tetragonal axes of symmetry of the cubic system. In the rhombic system also, the three rectangular axes of reference are identical with the three diagonal axes of symmetry, and in the monoclinic

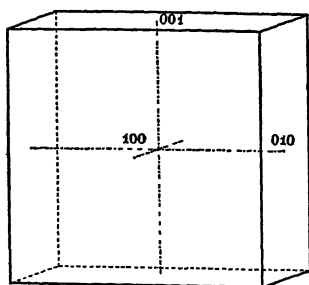

FIG. 40.—Axial Planes of a Rhombic Crystal.

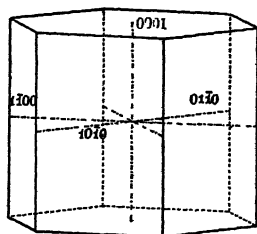

FIG. 43.—Hexagonal Prism of the First Order and its Four Axes.

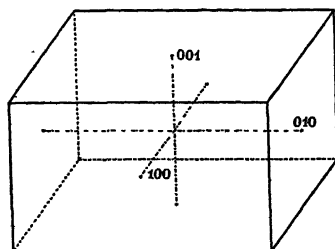

FIG. 41.—Axial Planes of a Monoclinic Crystal.

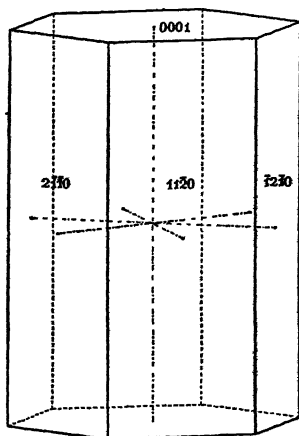

FIG. 44.—Hexagonal Prism of the Second Order.

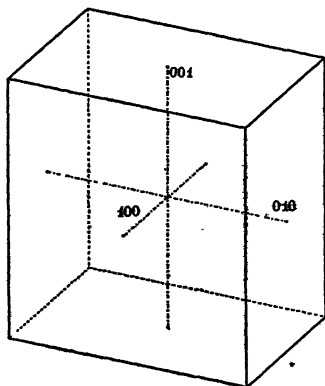

FIG. 42.—Axial Planes of a Triclinic Crystal.

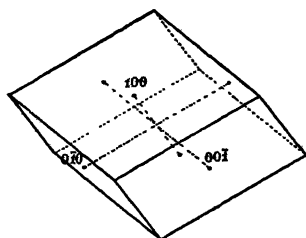

FIG. 45.—The Rhombohedron and its Three Equal Axes.

system the one axis of reference which is normal to the plane of the two inclined axes is the unique digonal axis of symmetry of that system.

Having thus evolved a scientific scheme of reference axes for the faces of a crystal, it is necessary in all the systems other than the cubic and trigonal, in which the axes are of equal lengths, to devise a mode of arriving at the relative lengths of the axes; for on this depends the mode of determining the positions of the various faces, other than the three parallel pairs (or four in the case of the hexagonal system) chosen as the axial planes. This is very simply done by choosing a fourth important face inclined to all three axes, when one of this character is developed, as very frequently happens, as the determinative face or plane fixing the unit lengths, a , b , c of the axes. When no such face is present on the crystal, two others can usually be found, each of which is inclined to two different axes, so that between them all three axial lengths are determined. The faces of the octahedron, of the primary tetragonal pyramid and the primary rhombic pyramid, and of the corresponding forms of the other systems, are such determinative planes, fixing the relative lengths of the axes. This fact will be clear from the typical illustration of the most general of these primary or "parametral" forms, the triclinic equivalent of the octahedron, given in Fig. 46, the faces being obviously obtained by joining the points marking unit lengths of the three axes.

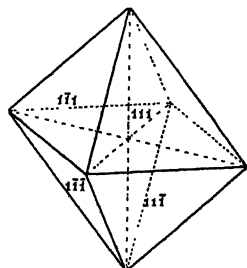

FIG. 46.—Triclinic Equivalent of the Octahedron.

It will thus be noted that the letters a , b , c will stand not only for the axial directions, but also represent specific lengths along those axes. In this triclinic system, and also in the monoclinic and rhombic systems, for all three of which systems the three axes, a , b , c , are of unequal lengths, it is usual to take the length of b as unity, when the "Ratio of the Axes," one of the important "elements" of a crystal, may be written as $a : 1 : c$, the a and c being the actual values of $\frac{a}{b}$ and $\frac{c}{b}$. That is, to give the axial ratio its simplest expression we divide out a , b , c by the actual length of b . In the cubic system, as all three axes are of equal length, the ratio may be written $a : a : a$ or $1 : 1 : 1$, or it may be omitted altogether. In the tetragonal system the two horizontal axes, a and b , are equal, so the ratio becomes $a : a : c$, or simply $1 : c$. In the hexagonal system the three horizontal axes are all equal, so the ratio is $a : a : a : c$, which, as for the tetragonal system, is in practice simply

expressed as 1 : c . In the three rectangular systems (cubic, tetragonal, and rhombic) and the hexagonal system, no other "element of symmetry" is required, as the angles between the axes are all 90° , or (in the hexagonal system) 60° , by virtue of the nature of the system of symmetry itself. In the monoclinic system, however, another element is required, β , the angle between the two inclined axes; and in the triclinic system three angular elements are required, α , β , γ , the angles between the three axes, none of which are rectangularly disposed to each other, whereas in the monoclinic system, α and γ are 90° . Trigonal crystals are either described like hexagonal ones, or preferably are described with reference to the edges of the rhombohedron as axes, as shown in Fig. 45 on page 37. As the rhombohedron is only a cube compressed, or elongated, along a diagonal, the axial lengths and angles are equal, but the angle is in general not 90° . This angle α is the only element requiring determination.

Having thus settled the directions of the crystallographic axes and their relative lengths, it is the next step which reveals the remarkable law to which reference was made at the opening of this chapter. For we find that all other faces on the crystal, however complicated and rich in faces it may be, cut off lengths from the axes which, compared with the parametral lengths, are represented exactly by low whole numbers, that is, either 2, 3, 4, or possibly 5, and very rarely more than 6 unit lengths. By far the greater number of faces do not cut off more than three unit-lengths from any axis. Prof. Miller, of Cambridge, in the year 1839, gave us a most valuable mode of labelling and distinguishing the various faces by a symbol involving these three axial values, employed, however, not directly but in an indirect yet very simple manner. If m , n , r be the three numbers expressing the intercepts cut off by a face on the three axes, a , b , c respectively, and if the Millerian index numbers be represented by h , k , l , then—

$$m = \frac{a}{h}, \quad n = \frac{b}{k}, \quad r = \frac{c}{l},$$

or,

$$h = \frac{a}{m}, \quad k = \frac{b}{n}, \quad l = \frac{c}{r}.$$

Each figure or "index" of the Millerian symbol is thus inversely proportional to the length of the intercept on the axis concerned. The intercepts themselves, written as $ma : nb : rc$, are used as symbols in another mode of labelling crystal faces, suggested by Weiss, but this method proves too cumbersome in practice. It should be noted that the m , n , and r of the symbols of Weiss are not the same as those used above in explaining the Millerian symbols; in the latter case m , n , r represent the actual intercepts, whereas

in the Weiss symbols m , n , r represent the low whole numbers by which the unit axial lengths are multiplied.

The Millerian symbol of a face is always placed within ordinary curved brackets (), but if the symbol is to stand for the whole set of faces composing the form, the brackets are of the type { }. Thus the Millerian symbol of the fourth face (that in the top-right front octant), determinative of the unit axial lengths, is (111), as shown in Fig. 46, the face in question being marked with this symbol; while the symbol {111} indicates the set of faces of the whole or such part of the double pyramid as composes the unit form. In the triclinic system this form only consists of the face (111) and the parallel one ($\bar{1}\bar{1}\bar{1}$), but in the case of the regular octahedron of the cubic system it embraces all the eight faces. The triclinic octahedron, Fig. 46, is thus made up of four forms of two faces each. A negative sign over an index indicates interception on the axis a behind the centre, on the axis b to the left of the centre, or on the vertical axis c below the centre.

To take an actual example, suppose a face other than the primary one to make the intercepts on the axes 4, 2, 1; in this case $h=a/4$, $k=b/2$, and $l=c/1$, that is, when referred to the fundamental primary form for which a , b , c are each unity, $h=\frac{1}{4}$, $k=\frac{1}{2}$, $l=1$, or, bringing them to whole numbers by multiplying by 4, $h=1$, $k=2$, $l=4$, and the symbol in Millerian notation is (124). Again, suppose we wish to find the intercepts on the three cubic axes made by the face (321) of the hexakis octahedron shown in Fig. 21. To get each intercept we multiply together the two other Millerian indices, and if necessary afterwards reduce the three figures obtained to their simplest relative values. For the face (321) we obtain 2, 3, 6. This means that the face (321) in the top-right-front octant of the hexakis octahedron cuts off two unit lengths of axis a , three unit lengths of axis b , and six unit lengths of axis c . No fractional parts thus ever enter into the relations of the axial unit-lengths intercepted by any face on a crystal, and the whole numbers representing these relations are always small (except in rare cases of crystals of considerable size, exceedingly rich in faces), the number 6 being the usual limit.

This important law is known as the "Law of Rational Indices," and is the corner-stone of crystallography. A forecast of it was given in Chapter III, in describing how it was first discovered by Haüy, and it was shown how impressed Haüy was with its obvious significance as an indication of the brick-like nature of the crystal structure. What the "bricks" were, Haüy was not in a position to ascertain with certainty, as chemistry was in its infancy, and Dalton's atomic theory had not then been proposed.

That Haüy had a shrewed idea, however, that the structural

units were the chemical molecules, or aggregates of a few molecules, and that while the main lines of symmetry were determined by the arrangement of these molecules, or groups, its details were settled by the arrangement of the atoms in the molecules, is clear to anyone who reads his 1784 "Essai" and 1801 "Traité," and interprets his *molécules intégrantes* and *élémentaires* in the light of our knowledge of to-day.

Before we pass on, however, to consider the modern development of the real meaning of the law of rational indices, as revealed by recent work on the internal structure of crystals, it will be well to consider first, in the next chapter, the essential facts now known as to the nature of the process of crystallisation itself, and in the subsequent chapter to discuss further the subject of crystal symmetry, and to describe the current mode of constructing a comprehensive, yet simple, plan of the faces present on a crystal.

CHAPTER VI

HOW A CRYSTAL GROWS FROM A SOLUTION

ONE of the most deeply interesting aspects of a crystal, especially from the point of view of the history of crystallographic investigation, concerns the mysterious process of its growth from a solution (in a solvent) of the substance composing it. The story of the elucidation, as far as it has yet been accomplished, of the nature of crystallisation from solution in water is one of the most romantic which the whole of scientific progress can furnish. Again we are struck with the parallelism between crystals and living objects. For just as the discovery of bacteria, the infinitesimal germs of life, has given an immense impetus to our knowledge of disease and been blessed with most beneficent effects in combating the ravages of the latter, so the discovery that crystal germs of most common crystallised substances, of no larger size than bacteria, are floating about in our atmosphere, and ready at any time to drop into our solutions and, if the latter are in the proper receptive condition, to set them crystallising, is little less marvellous, and has had as profound an effect on our knowledge of the process of crystallisation. A true story, told to the Royal Society a few years ago, may serve to illustrate the point. A new chemical compound had been discovered, produced synthetically by chemical operations in the laboratory, and at the time there could obviously be no crystal-germs, minute crystallites of the dimensions of possibly only a comparatively few chemical molecules, of this hitherto unknown and non-existent substance floating about in the air. It was found impossible to obtain the deposition of crystals in the ordinary way, from solutions of the substance in its ordinary solvent, although they were in the condition of proper receptivity above referred to, on account of the absence of such germs in the air. But later on, when the air of the laboratory had become impregnated with such germs, on account of the daily handling of the substance in the laboratory, no difficulty was any longer found in obtaining good crystals quite readily from these solutions.

We are at first inclined to wonder whether such extraordinary statements can possibly be sober facts. Yet such is, indeed, the

case, and it will be very well worth devoting a chapter to the story of how we have at length arrived at definite knowledge concerning the process of crystallisation from the state of solution in water. For water is the ordinary solvent from which we obtain our crystals, that is, such as are prepared artificially in the laboratory. The laws which have been discovered to hold for aqueous solutions are, however, equally applicable to the cases where other solvents are used, such, for instance, as the usual organic solvents like alcohol, ether, chloroform, acetone, and benzene.

The conditions under which crystallisation occurs from the liquid state, or from solution of the substance in a solvent, have been accurately determined experimentally by H. A. (now Sir Henry) Miers,¹ and they bear out in the main the predictions from theoretical considerations which were made by Ostwald.² Taking first the case of crystallisation from solution, there are two distinct curves representing the degree of solubility of the solid substance and of supersolubility. The well-known ordinary solubility curve is obtained by taking the temperature for abscissæ and concentration for ordinates, so that any point on the curve indicates the amount of the solid substance which the solvent can hold in solution at that particular temperature. Now the fact that supersaturation may occur has long been established, the phenomenon being of frequent occurrence; and it is common knowledge that a supersaturated solution may be preserved for a long time without crystals being deposited from it, provided the liquid be maintained quietly at rest. Obviously, therefore, this condition of supersaturation ought to be represented by a second curve a few degrees lower as regards temperature than the solubility curve, and its conditions were fairly fully predicted by Ostwald, after collecting together and analysing the results of the experiments of Gernez, Lecoq de Boisbaudran, J. M. Thomson, de Coppet, Lefebvre, and Roozeboom. It was reserved for Miers, however, to discover a means of experimentally tracing this curve, by observations of the refractive index of the solution. The point at which the deposition of crystals from the supersaturated solution occurs is immediately indicated by a sudden change in the refraction of the liquid, the refractive index attaining its maximum value at the temperature of spontaneous crystallisation, and then dropping suddenly the moment the crystals begin to fall. Moreover, the solution at the same time records its own strength, for the refractive index varies directly as the amount of salt dissolved. The determination of the strength of the solution at the critical moment itself had previously proved an impossibility by ordinary methods.

¹ *Journ. Chem. Soc.*, 1906, 89, 413; *Proc. Roy. Soc., A*, 1907, 79, 322.

² "Lehrbuch der Allgemeinen Chemie," Vol. II, Part 2, p. 780.

Fig. 47 gives a general diagrammatic representation of Miers' results for a typical crystalline substance soluble in water. S is the ordinary solubility curve, which may also be termed the "curve of crystallisation by inoculation." For as soon as the solution reaches this condition of normal saturation it is liable to be caused to commence crystallising if a germ crystal, that is, a miniature crystallite floating in the air as dust, of the substance itself or of one isomorphous with it and capable of forming parallel growths or overgrowths or mixed crystals with it, fall into the solution from the air. The more perfectly isostructural (that is, the closer the molecular volumes and topic axial ratios) the substance and the germ

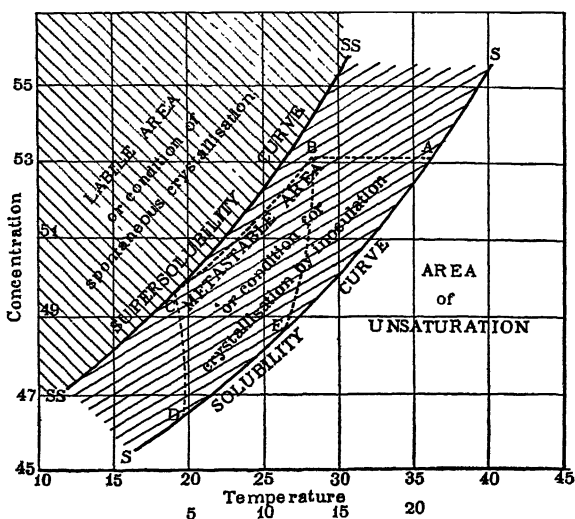

FIG. 47.—Diagram illustrating the Conditions for Crystallisation from Solution or the Liquid State.

crystal are, the more effective is the latter in starting the crystallisation of the former. It has been a revelation to us that such minute crystallites of all common substances are scattered broadcast in our atmosphere, and that sooner or later one will introduce itself into any solution set to crystallise which is not sealed up or placed in a vessel with filtering plug of cotton-wool in its neck or other aperture.

SS is the supersolubility curve, situated approximately 10° to the left of the solubility curve as regards temperature, but about as much above as regards concentration, so that the two curves usually run diagonally and more or less parallel to each other across the diagram. This supersolubility curve may be also called the "curve of spontaneous crystallisation," for it represents the conditions under which alone crystals may begin to form without the initiating

impulse of inoculation by a germ-crystallite. On the suggestion of Ostwald it is also termed the "metastable limit," and the whole area between the solubility and supersolubility curves is named the area of metastability, that which represents the "metastable" condition of the solution. Within this area the conditions are those for the start of crystallisation by inoculation. The area beyond the supersolubility curve represents the "labile" state, in which the conditions are those for spontaneous crystallisation, inoculation being no longer necessary. These precise results will, it is hoped, be quite clear with the aid of Fig. 47.

Hence, when a cooling solution not quite saturated at the higher starting temperature is stirred in an open vessel a slight shower of crystals, started by inoculation, appears when the saturation point is reached, which Miers calls a "metastable shower," corresponding to the ordinary solubility curve; the liquid then goes on cooling without depositing the main bulk of the excess which that curve indicates ought to be deposited, if it represent the whole truth. But when the temperature of the supersolubility curve about 10° lower is reached, a much more copious shower falls by spontaneous crystallisation, the "labile shower."

In a closed vessel, such for instance as a glass tube sealed with the aid of the blowpipe after the introduction of the solution, on cooling after heating to a temperature superior to that of saturation, the first shower never falls at all, no amount of shaking inducing the deposition of crystals at the ordinary saturation point, proving that the slight shower of the experiment in the open vessel is due to crystal-germs introduced from the atmosphere. The second shower of crystals falls at the lower temperature just as before, however, at the temperature of the supersolubility curve, indicating that this shower is due in both cases to spontaneous crystallisation. Solutions thus enclosed in sealed tubes, to which inoculating dust crystals cannot have access, can never be made to crystallise at any temperature higher than that given by the supersolubility curve, however agitated, although they immediately do crystallise, if shaken, as soon as that temperature is reached during the cooling. If allowed to remain absolutely quiet, however, the temperature may fall considerably lower before any crystallisation occurs, the labile region being frequently well penetrated before this happens. When crystallisation does supervene, the temperature usually rises somewhat. After the labile shower has been deposited, the crystals continue to grow steadily further, until the metastable region has been traversed, and the saturation state is eventually reached, when final equilibrium is produced.

The proof that the crystals deposited in the metastable condition were started by the advent of atmospheric germ-crystals—that is,

by infinitesimal but perfectly structurally developed crystals, carried by their very lightness like the particles of dust which are only revealed in the path of a sunbeam as seen against a dark background—was afforded by a series of experiments with a mixture of two rare organic chemical preparations, salol (phenyl salicylate) a substance melting at $42^{\circ}\cdot 5$, and betol (β -naphthol salicylate) another melting at 92° , which Miers assumed were not likely to be present in ordinary air. The assumption proved well grounded, and the first shower never fell at all in the earlier experiments in which mixtures of these two substances were allowed to cool in open vessels, from the state of fusion. But very soon the air of the laboratory became impregnated with crystallites of both substances, due to the very operations themselves being carried on in contact with the air, and in the later experiments the first shower of crystals did fall. The experiments were really designed to effect the determination of the solubility curve for salol and betol in each other, that is, the freezing-point curve of their mixtures, and the discovery of the so-called "eutectic" point at which a mixture of constant composition solidifies at a definite temperature. But incidentally the experiments also served to establish similar laws for the production of crystals from the liquefied state, by cooling below the melting point, to those applying to crystallisation from solution. In the case of the mixtures of the substances the one of lower melting point acted as a solvent for the one of higher melting point, just as water does for salt. Two curves corresponding to the ordinary freezing point and to the limit of superfusion were established, analogous to the solubility and supersolubility curves. Pure salol alone proved to crystallise spontaneously at 33° , $9\frac{1}{2}^{\circ}$ below its melting point, and the refractive index attained a maximum for this temperature. Betol spontaneously crystallised at 79° , 13° below its melting point.

Two general cases of crystallisation are shown by the dotted curves ABCD and ABE in Fig. 47. The first, represented by ABCD, is the case of a supersaturated solution, made by adding the salt to hot water, being allowed to cool slowly while stirred. The solution cools from A to B without anything visibly happening, no crystal-germ falling into the solution until B is reached, somewhere well within the metastable region. When the germ has fallen in, however, crystals begin to appear as a slight shower at B, and from B to C they continue to grow slowly. On reaching the labile condition at C a cloud of crystals, the heavy shower, is deposited, and the concentration falls rapidly to D on the solubility curve, generally with slight rise of temperature.

The second case is the important one employed by the author in the investigations which will be found described in his *Crystalline*

Structure and Chemical Constitution (Macmillan and Co., 1910) and *Crystallography and Practical Crystal Measurement*, Second Edition (Macmillan and Co., 1922), for the purpose of producing crystals of high perfection for goniometrical investigation. The method can be confidently recommended as the one best adapted to afford good measurable crystals, and is of quite general application. The solution is made up so as to be in the metastable condition, that is, only slightly supersaturated for the ordinary temperatures. Eventually, while the solution is at rest in a protected place, free from draughts or vibration, and after it has cooled to the temperature of the air, a crystal-germ enters, followed probably by others; each forms a centre of crystal growth, which proceeds very slowly and deliberately, keeping pace with the evaporation in such a manner that the labile condition is never reached. The natural result is the production of very well-formed crystals bounded by excellent faces, truly plane and free from striation or distortion.

When the operation is arranged to occur during the night, as will usually be the case, the solution being set out to crystallise in a quiet and protected place on the previous afternoon or evening, the slight fall of temperature during the night gently assists the process and almost ensures a good crop of a few well-formed crystals, large enough for goniometrical purposes, next morning. They should be removed before the temperature begins to rise again with the advent of the sun, dried with blotting-paper and by air exposure for a short time, and stored in a miniature bottle labelled with the name or formula of the substance and the date of collection of the crop. In such cases the labile state is never reached, and the course of the crystallisation is represented by the curve BE. The whole conditions for the curve ABE, however, would correspond to much lower temperatures, such as those given at the foot of the diagram below the word "temperature," rather than to the upper row of temperature abscissæ suitable for the other purposes of the diagram already referred to. Crystallisation might well begin about 13° or 14°, as shown at B, and the liquid would cool a couple of degrees or more during the night while crystallisation was steadily proceeding, until equilibrium was reached at E on the solubility curve.

The diagram does not represent any substance in particular, but is a perfectly general one, corresponding to the facts observed with most of the very varied salts worked with by Miers and those of which the author has had experience. The exact temperatures and concentrations will, of course, differ for each substance.

A beautiful experimental demonstration of crystallisation from the metastable and labile conditions of solution respectively is afforded by potassium bichromate, $K_2Cr_2O_7$. When crystallised from a metastable solution under conditions of quietude, this salt

is slowly deposited in bright orange-coloured and excellently formed crystals, often of considerable size, belonging to the triclinic system of symmetry; they are bounded by good pinakoidal (pairs of parallel) faces intersecting in sharp edges. But when the crystallisation occurs from a labile solution, being much more rapid, it takes the form of feathery or arborescent branching skeletal growths, there being inadequate time for the formation of well-developed crystals.

Fig. 48, Plate XII, is a photographic reproduction of well-formed crystals of potassium bichromate, grown from a solution in the metastable condition on a microscope slip, just as they are seen through the microscope in the slow act of formation, employing a $1\frac{1}{2}$ -inch objective. The crystallisation had been started by germ crystals of the salt falling in from the air, after which the drop, placed within a ring of hardened gold-size on the slide, had been covered with a cover-glass, under which the crystallisation had proceeded with sufficient slowness to enable a successful photograph to be taken, when the camera was subsequently attached above the vertically arranged microscope. An upright micrographic apparatus had been designed by the author specially for this photography of growing crystals, many of the results of which are reproduced in this book.

Fig 49 (same Plate) is the reproduction of another photograph taken under similar conditions, but employing a hot and somewhat more concentrated solution of potassium bichromate, and making the exposure at the moment when, in the particular field chosen, a rapid labile crystallisation was just completing itself, the rapidity of growth of the feathery skeletal crystals having just become arrested. Indeed, the branches are frequently terminated by small well-formed crystals, the rapid growth having been succeeded by a final slow crystallisation where the solution had discharged its labile excess and attained once more the metastable condition.

This experiment with potassium bichromate lends itself admirably to lantern demonstration with the projection microscope. When the drop of hot concentrated solution is first placed on the warmed microscope slip, and the latter laid on the stage, nothing visible on the screen happens for a minute or two, the solution becoming, however, more or less rapidly cooled. But suddenly, the drop having cooled sufficiently to bring the solution to the labile condition of supersaturation corresponding to the conditions for spontaneous crystallisation indicated by the supersolubility curve, arborescent or feathery growths begin to shoot out from various points in the field, often near the margin, and traverse the screen so rapidly that in a moment or two it is filled with them. The crystallisation then slows down once more, the labile shower of excess having become exhausted, and the terminations of the branches

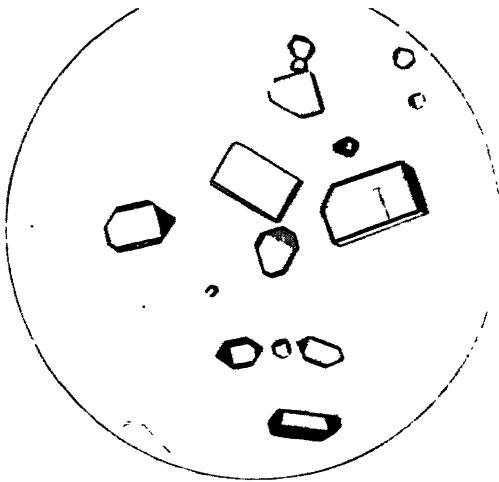

FIG. 48.—Potassium Bichromate slowly crystallising from a Metastable Solution



FIG. 49.—Potassium Bichromate rapidly crystallised from a Labile Solution

CHARACTERISTIC DIFFERENCE IN THE CRYSTALS DEPOSITED FROM METASTABLE AND LABILE SOLUTIONS

and ramifications begin to develop into good little crystals, which thus hang like fruit on a tree. The experiment is rendered the more brilliant and beautiful by the bright orange colour of the crystals.

In Fig. 50, Plate XIII, facing page 72, a reproduction of a photograph of a similar crystallisation from a labile solution of ammonium chloride is given. This salt is also particularly suitable for screen demonstrations. The beautiful skeletal ramifications follow the axial directions of the cubic axes, ammonium chloride crystallising in the pentagonal-icositrahedral class of the cubic system. Good crystals may, however, be very slowly grown from metastable solutions, and they usually exhibit as the principal forms the icositrahedron (predominating), cube, octahedron, rhombic dodecahedron, and the class-distinguishing pentagonal icositrahedron. If the growth be retarded by the addition of a little of the substance urea to the solution, the ammonium chloride crystallises in well-formed cubes. The rapid growths by spontaneous crystallisation of labile solutions, however, invariably take the form of the rectangularly branching feathery crystals shown in Fig. 50.

Further light has been thrown on the act of crystallisation by another most interesting research of Sir Henry Miers concerning "vicinal faces,"¹ such as the three very low pyramid faces (forming a very flat triakis octahedron) which often replace each octahedron face on a crystal of alum which has been grown somewhat rapidly. The author has frequently observed this phenomenon in the course of the numerous crystallisations required for the investigation of the sulphates and selenates (see Chapter XI). It may be described in general terms as the replacement of primary faces possessing the simplest rational indices by faces having such high indices that it is doubtful whether they ought really to be represented by indices at all. The number of such vicinal faces which replace the simple face depends on the symmetry of the crystal, to which, of course, they conform. Thus, while three such vicinal faces replace an octahedral face, and two replace the face of a tetragonal prism, the simple primary prism face of a rhombic or monoclinic crystal would only be replaced by one, which may have a deformation of as much as even 30' from the correct position of the prism-face, and on either side of it. Indeed, it is possible for a whole succession of such vicinal faces to be developed within the degree of arc which may in extreme cases separate the limiting values on each side of the prism face, and such are often seen and make up the well-known bundle of images afforded on the goniometer by a bad face, a face which would cause the author at once to reject the whole crystal for measurement purposes. One of the faces, even in cases such as

¹ *Phil. Trans.*, 1903, A, 202, 459.

alum or a tetragonal crystal, where three or two might have equal values as regards the symmetry, generally predominates, and affords a very much more brilliant image of the goniometer signal than the others in the bundle, so that an unwary observer might easily come to the conclusion that this was the really valid image corresponding to the octahedron face or to the simple primary prism face, or whatever particular face was expected in the neighbourhood indicated by the bundle of images. Obviously, however, it might only be one of three or two equally valid faces of a vicinal form, which had grown predominately during the last period of growth previous to removal from the mother liquor.

The explanation of this interesting phenomenon of the production of vicinal faces is one intimately connected with the structure of crystals, and it forms one of the strongest confirmations of the correctness of the theory of crystal structure the basis of which is the molecular or polymolecular space-lattice. Sir Henry Miers is in full agreement with the author in emphasising the importance of the space-lattice formed by the "points" representative of the molecules or small groups of molecules, and analogously chosen in the molecules or groups. He says: "Whatever structures may be necessary to account for other features of crystals, there is little doubt that we are justified in regarding their faces as the planes of a space-lattice."¹ Now Wulff,² who has contributed very considerably to our knowledge of the nature of the act of crystallisation, has proved, from his own investigations and those of Weyberg, carried out at his suggestion in his laboratory at Warsaw,³ that faces of greatest reticular density, that is, those along which the points of the space-lattice are most thickly strewn, are those which grow the most slowly, and therefore are the best developed. This latter will be obvious on a little consideration, for the faces of less reticular density which grow more, tend in doing so to extend the boundaries of the faces of greatest reticular density, and thus to enlarge those faces. Hence the usual predominating planes on a crystal must be those of high reticular density; and these are such as are represented by the simplest indices, the faces most dense of all in points being the primary ones.

But it has been shown from the researches of Sir Henry Miers that vicinal faces are often produced in preference to these simple-index planes of high density, and such vicinal faces, although the nearest (in angular position) of all possible faces to those simple index planes, are themselves of excessively low reticular density, so much so that if represented by indices at all they can only be indicated by very

¹ *Phil. Trans.*, 1903, A, 202, 519.

² *Zeitschr. für Kryst.*, 1901, 34, 449.

³ *Loc. cit.*, p. 531.

high numbers, not such as we are accustomed to consider as in keeping with the simple spirit of the law of rational indices. Taking the example worked out most fully by Miers, the octahedral crystals of alum, it is a fact that the cubic faces of highest reticular density are those of the cube itself, then come in order those of the rhombic dodecahedron and those of the octahedron. Hence, the density of octahedral faces is very high. But those of the very low triakis octahedron, which Miers finds to replace the octahedron faces so frequently as vicinal faces, are of excessively low reticular density.

Miers explains the appearance of the latter instead of octahedral faces by assuming that the supersaturated liquid in contact with the growing crystal consists of the particles (molecules) of salt uniformly mingled with those of water, the solvent, and that the act of crystallisation consists of the escape of the water and solidification of the salt. Consequently, the salt particles just before crystallisation cannot be so dense as they are along primary planes of the crystal, as they are separated by the water particles, which are presumably much more numerous. Hence it is that they are not deposited along the planes of high reticular density, but along vicinal planes of low density of points. For instance, he shows that the shower of salt particles upon a cube face would have to be so dense that there would be insufficient room for the water particles. The density in a cube face is 114 times as great as that in one of the vicinal planes observed. Now, 100 cubic centimetres of solid alum weigh 172 grammes, and 100 c.c. of the solution depositing crystals contain 9.74 grammes of alum. Thus the density of the growing crystal of alum is nearly 18 times that of the alum in the adjacent saturated solution.

Consequently the deposition of the salt particles, in a moderately quick crystallisation, when insufficient time is afforded for the deliberate escape of the water particles and for the orderly re-arrangement of the salt particles, occurs along vicinal planes instead of along the primary planes. For it must not be forgotten that whenever it has the opportunity of coming into operation there is a directive molecular force of some kind, which controls the operation of crystallisation, and which undoubtedly attempts to cause, and given adequate time and scope succeeds in causing, the production of faces of high reticular density, the fundamentally important primary faces of lowest indices, and which are often those along which cleavage occurs. Wulff emphasises this in saying (*loc. cit.*, p. 461): "Bei der Krystallisation orientiren sich die Molekeln auf den Flächen des Krystalles ganz gleichförmig durch den Einfluss der Richtkraft der Krystallisation." The more rapidly the crystallisation occurs, however, the less chance is there for this force to attain its ultimate object.

This highly interesting explanation of Sir Henry Miers, supported as it is by the work of Wulff, and confirmed also in many respects by the observations of the author, whose great aim throughout his investigations has been to avoid the production of such vicinal faces, throws an important light on the nature of the act of crystallisation. It renders the reason clear why crystals which are very slowly grown from solutions only feebly supersaturated and under conditions of absolute rest, protected from either air currents or preventable earth tremors—conditions which the author has taken quite exceptional pains to procure for the preparation of the crystals used in the investigation of the sulphates and selenates of the rhombic simple salt series and monoclinic double salt series—are occasionally obtained quite free from any sign of such vicinal faces. They are small perfect individuals exhibiting primarily the faces of high reticular density, that is, the faces of the simple forms of low rational indices; and these faces are absolutely plane, affording one single brilliant image of the goniometer signal, which can be adjusted with great precision to the cross-wires of the telescope. For the slower the growth, the more time is afforded for the escape of the water molecules, and for the salt molecules to deposit themselves as directed by the molecular guiding force of crystallisation, along the planes of high reticular density. In many of his experiments Miers expressly stirred the solution, to prevent concentration currents. Hence his experiments in which vicinal faces were produced are not comparable with the author's slow, quiet growths.

The work of Miers assists in the proof that the constancy of angle to within one or two minutes of arc is a real property of the crystals of a substance. For previously the frequent presence of vicinal faces rather than the simple forms of high reticular density, and which had been mistaken for the latter, had caused Pfaff in 1878¹ and others to conclude that variations from the true crystal angle amounting to as much as 30' were of common occurrence as the result of strain during deposition.

Brauns² in 1887 made a careful series of measurements of very good octahedral crystals of lead nitrate, and found 13' 20" the largest deviation of a good image from the theoretical position. He imputed it to the action of gravity as a disturbing cause during deposition. The researches of Sir Henry Miers have cleared away all this misconception, in proving that the bright images referred to, taken for those of the simple primary form, are not such at all, but vicinal faces of very low reticular density.

¹ *Sitzungsber. d. Physik. Med. Soc., Erlangen, 1878, 10, 59.*

² *Neues Jahrbuch, 1887, 138.*

CHAPTER VII

THE DISTRIBUTION OF CRYSTAL FACES IN ZONES, AND THE MODE OF CONSTRUCTING A PLAN OF THE FACES. THE REFLECTING GONIOMETER

It will have been clear from the facts related in the previous chapters that the salient property possessed by all crystals, when ideal development is permitted by the circumstances of their growth, and the substance is not one of unusual softness or liable to ready distortion, is that the exterior form consists of and is defined by truly plane faces inclined to each other at angles which (unless the symmetry be cubic) are specific and characteristic for each definite chemical substance; and that these angles are in accordance with the symmetry of some particular one of the thirty-two classes of crystals, and are such as cause the indices of the faces concerned to be rational small numbers.

It will also be clear that, given the presence of any face other than the three axial planes, the symmetry of the class—supposing the crystal to exhibit some development of symmetry and not to belong to class 1 of the 32, the general case possessing no symmetry—will require the repetition of this face a definite number of times on other parts of the crystal. Such a set of faces possessing the same symmetry value we have already learnt to call a "Form," and the faces composing it will have the same Millerian index numbers in their symbols, but differently arranged and with negative signs over those which relate to the interception of the back part of the *a* axis, the left part of the *b* axis, or the lower part of the vertical *c* axis; that is, parts to the front and right, and above, the centre of intersection of the three crystal axes are considered as the positive parts of those axes.

A form, if of general character, that is, if composed of faces each of which is inclined to all three axes, will comprise more faces the higher the symmetry. Thus, in the cubic system, the form shown in Fig. 21, on page 26, the hexakis octahedron, comprises as many as forty-eight faces, all covered by the form symbol $\{321\}$; while in the rhombic system the highest number of faces in a form is eight, in the monoclinic only four, and in the triclinic system two (parallel). It will also have become clear that the law of rational

indices limits the number of forms possible of any one type. For instance, very few hexakis octahedra are known, the most frequently occurring ones besides $\{321\}$ being $\{421\}$, $\{531\}$, and $\{543\}$. Forms, of any class, possessing higher indices than these are very rare, especially in the systems of lower symmetry.

We next come to a further very interesting fact about crystals. Let us imagine a crystal, on which the faces are fairly evenly developed, to be placed in the middle of a sphere of jelly, as indicated in Fig. 51 (reproduced from a Memoir by the late Prof. Penfield), so that the centre or origin of the axial system of the crystal and the centre of the sphere coincide. Let us now further imagine that long needles are stuck through the jelly and

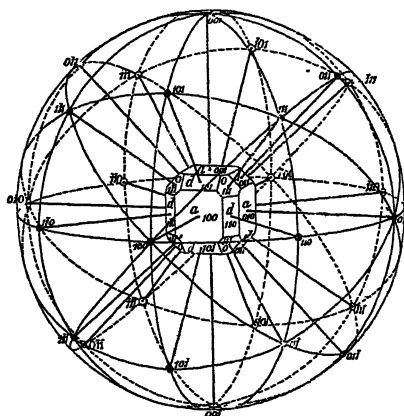

FIG. 51.—The Spherical Projection.

the crystal, one perpendicular to each crystal face, and so as to reach the centre. The crystal represented in Fig. 51 is a combination of the cube a , octahedron o , and rhombic dodecahedron d . If such a thing as we have imagined were possible, we should find that the needles would emerge at the surface of the sphere in points which would lie on great circles, that is, on circles which represent the intersection of the sphere by planes passing through the centre. Moreover, the points

would be distributed along these circles at regularly recurring angular positions, corresponding to the symmetry of the crystal. If the crystal belonged to one of the higher systems of symmetry, it would happen that four of the points on at least one of these great circles, and possibly on three of them, would be 90° apart, that is, would be at the ends of rectangular diameters, which would most likely be the axes of reference. The other points would be distributed symmetrically on each side of these four points.

The great circles on which the points are thus symmetrically distributed—and they may legitimately be taken to represent the faces, for tangent planes to the sphere at these points would be parallel to the faces—are known as “zone circles,” and the faces represented by the points on any one of them form a “zone.” Now a zone of faces has this practical property, that when the crystal is supported so as to be rotatable about the zone axis—which is parallel to the edges of intersection of all the faces com-

posing the zone, and is the normal to the plane of the great circle representing the zone—and a telescope is directed towards the crystal perpendicularly to the zone axis, while a bright object such as an illuminated slit is arranged conveniently so as to be reflected from any face of the crystal into the telescope, an image of it being thus visible in the latter, then it will be found that on rotating the crystal a similar image will be seen reflected in the telescope from every face of the zone in turn. Moreover, when the crystal is mounted on a graduated circle, the angle of rotation between the positions of adjustment to the cross-wires of the telescope of any two successive images, reflected from adjacent faces of the crystal, is actually the angle between the two points representing the faces concerned on the zone circle, and is the supplement of the internal dihedral angle between the two crystal faces themselves. It is, in fact, the angle between the normals (perpendiculars) to the two faces, the angle which is measured on the goniometer.

This is, indeed, the very simple principle of the reflecting goniometer, invented by Wollaston in the year 1809, and which in its modern improved form is the all-important principal instrument of the crystallographer's laboratory. The work with it consists largely in the measurement of the angles between the faces in all the principal zones developed on the crystal. The very fact, however, that crystal faces occur so absolutely accurately in zones immeasurably lightens the labours of the crystallographer, and is one of prime importance.

The most accurate and convenient modern form of reflecting goniometer, reading to half-minutes of arc, and provided with a delicate adjusting apparatus for the crystal, is shown in Fig. 52. It is constructed by Fuess of Berlin.

The graduated circle *a* is horizontal and is divided directly to 15', the verniers enabling the readings to be carried further either to single minutes, which is all that is usually necessary, or to half-minutes in the cases of very perfect crystals. The divided circle is rotated by means of the ring *b* situated below, and the reading of the verniers is accomplished with the aid of the microscopes *c*. The circle which carries the verniers is not fixed, except when this is done deliberately by means of the clamping screw *d*, but rotates with the telescope *e* to which it is rigidly attached by means of an arm and a column *f*. A fine adjustment is provided with the clamping arrangement, so that the telescope can be adjusted delicately with respect to the divided circle. Both telescope and collimator are rigidly fixed (the telescope by the clamping screw *d*) at about 120° from each other during the actual measurements. The collimator *g* is carried on a column *h* definitely fixed to one of the legs (the back one in Fig. 52) of the main basal tripod of the

instrument. The signal slit of the collimator is carried at the focus of the objective about the middle of the tube *g*, the outer half of the latter being an illumination tube carrying a condensing lens to concentrate the rays of light from the goniometer lamp on the slit. The latter is not of the usual rectilinear character, but composed of two circular-arc jaws, so that, while narrow in the middle part like an ordinary spectroscope slit, it is much broader at the two ends in order to be much more readily visible; the central part is narrow in order to enable fine adjustment to the vertical cross-wire of the telescope to be readily and accurately

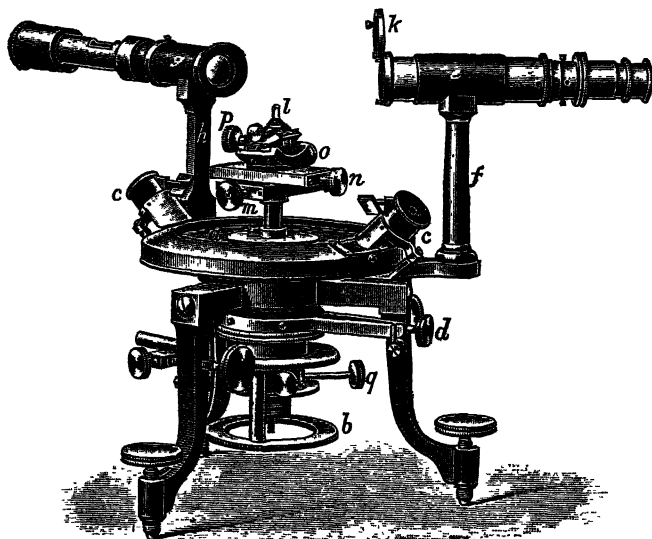

FIG. 52.—The Reflecting Goniometer.

carried out. The shape of this signal-slit will be gathered from the images of the slit shown in Fig. 66 (page 102) in Chapter XI. The telescope carries an additional lens *k* at its inner, objective, end, in order that when this lens is rotated into position the telescope may be converted into a low-power microscope for viewing the crystal and thus enabling its adjustment to be readily carried out.

The crystal *l* is mounted on a little cone of goniometer wax (a mixture of pitch and beeswax) carried by the crystal holder. The latter fits in the top of the adjusting movements, which consist of a pair of rectangularly arranged centring motions, and a pair of cylindrical adjusting movements; the milled-headed manipulating centring screws of the former are indicated by the letters *m* and *n* in Fig. 52, and those which move the adjusting segments are marked *o* and *p*. The top screw (unlettered) fixes the crystal holder.

The crystal on its adjusting apparatus can be raised or lowered to the proper height, level with the axes of the telescope and collimator, by means of a milled head at the base of the instrument, there being an inner crystal axis moving (vertically only) independently of the circle. Moreover, a second axis outside this enables the crystal to be rotated independently of the circle, the conical axis of which is outside this again. The two can be locked together when desired, however, by a clamping screw provided with a fine

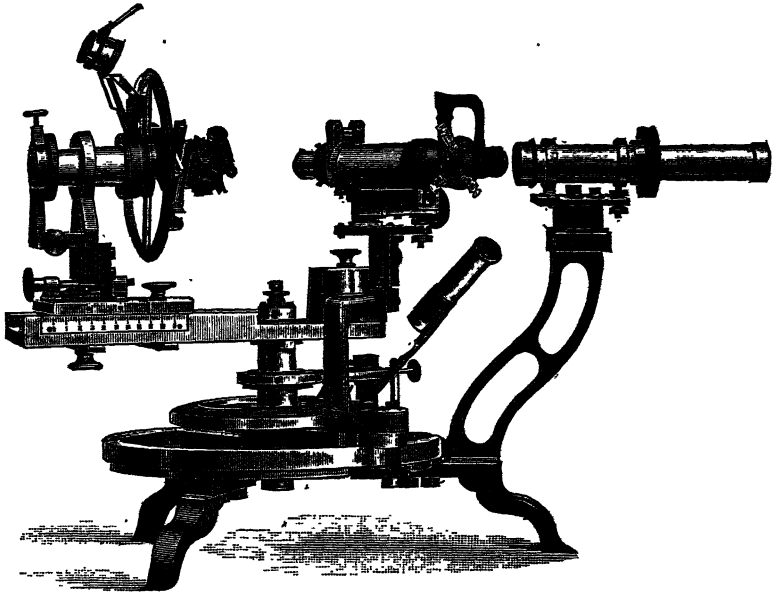

FIG. 53.—Two-circle Goniometer of V. Goldschmidt.

adjustment q . Freedom of movement of the crystal axis, unimpeded by the weight of the circle, is thus permitted for all adjusting purposes, the circle being only brought into play when measurement is actually to occur. With this instrument the most accurate work can be readily carried out, and for ease of manipulation and general convenience it is the best goniometer yet constructed. Messrs. Troughton and Simms, of Charlton, London, S.E., have also provided goniometers on similar lines and of a high order of accuracy.

Another type of goniometer has been much used by certain investigators during recent years, constructed on the theodolite plan with two circles, a vertical one and a horizontal one. One of the best known is shown in Fig. 53, and is the latest (1920) model, embodying all the desirable improvements and conveniences, as used by Prof. V. Goldschmidt of Heidelberg and his school. The

crystal is carried at the end of the horizontal axis of the vertical circle, instead of at the upper end of the vertical axis of the horizontal circle as in the ordinary goniometer shown in Fig. 52, although in another well-known type of two-circle goniometer, that of Czapski, it is so carried. The method of measurement of the crystal by the two-circle goniometer is also different to that with the single-circle instrument. Instead of measuring the interfacial angles in each zone completely, one after the other until the whole 360° are explored, resetting the crystal as often as is necessary in order to measure all the different zones of any importance developed, and thus recording the measurements essentially in zones—so convenient for the purpose of the construction of a stereographic projection—the two-circle method consists in determining the position of each face by two angular measurements (co-ordinates), namely, the azimuth angle ϕ , which is measured on the same circle as carries the crystal on its axis, and the altitude or polar distance angle ρ , which is measured on the other circle. To determine the latter, some prominent and eminently suitably situated face—for instance, the basal plane face (001) or (0001) when the system is one of the rectangular ones or the hexagonal, and such a face is actually developed—is chosen as the pole-face of reference, the zero of polar distance, $\rho=0^\circ$. Similarly, a prominent face, such as one of the important primary pinakoid faces (100) or (010), is arranged to be the zero of azimuth, $\phi=0^\circ$. Any other face on the crystal is then determined by its azimuth ϕ , and its polar distance ρ , as measured on the two respective and proper circles.

The two-circle goniometer proves very useful for rapid measurement, and especially for use with mineral crystals, which are so often only developed at one termination of their main prism-zone axis, being attached to their rock cavity at the other end. Such crystals can often be measured completely with only one setting on the goniometer wax of the crystal holder, by their undeveloped end, the prism zone being arranged parallel to the axis of the circle. But for very accurate measurement for research purposes with complete crystals the author still prefers the single-circle goniometer; when the instrument is constructed by such firms as Fuess or Troughton and Simms, whose circle-dividing engines are so perfect, it is accurate to a truly surprising degree of refinement, well within half a minute of arc, and it affords less possibility of looseness, and of undesirable relative movement of parts unrecorded by the measuring circle and verniers. Also the theodolitic measurements by the two-circle goniometer require special interpretation, and do not directly afford and make clear the zonal relationships, which are so very important, essential, and instructive, as regards the determination of the crystal symmetry.

The idea of regarding the centre of the crystal as the centre of a sphere, within which the crystal is placed (Fig. 51, page 54), gives crystallographers a very convenient method of graphically representing a crystal on paper, by projecting the sphere on to the flat surface of the paper, the eye being supposed to be placed at either the north or south pole of the sphere, and the plane of projection to be that of the equatorial great circle. The faces in the upper hemisphere are represented by dots which are technically known as the "poles" of the faces, corresponding to the points where the needles normal to the faces emerge from the imaginary globe, and all these points or poles lie on a few arcs of great circles,

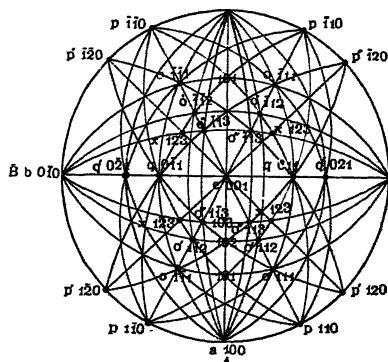

FIG. 54.—Stereographic Projection of Topaz.

which appear in the projection either also as circular arcs terminating at diametrically opposite points on the circumference of the equatorial circle, which forms the outer boundary of the figure and is termed the "primitive circle," or else, when the planes of the great circles are at right angles to the equatorial primitive circle, they appear as diametral straight lines passing through the centre of the primitive circle.

Such a "stereographic projection" offers a comprehensive plan of the whole of the crystal faces, which at once informs us of the symmetry in all cases other than very complicated ones. A typical stereographic projection, that of the rhombic crystal of topaz shown in Fig. 22 (page 26), is given in Fig. 54.

It will happen in all cases of higher symmetry, as in that of topaz, for instance, that the poles in the lower hemisphere will project into the same points as those representing the faces in the upper hemisphere; but in cases of lower symmetry, where they are differently situated, they are usually represented by miniature

rings instead of dots. From the interfacial angles measured on the goniometer the relative lengths and angular inclinations (if other than 90°) of the crystal axes can readily be calculated, by means of the simple formulæ of spherical trigonometry. Also, even in the most difficult general case of triclinic crystals, from five suitably situated measured angles we are able to calculate all the remaining angles of a crystal, however rich in faces it may be, and thus to check the values of any angles for which by reason of poorly reflecting faces the measurements are open to doubt. When the crystal is monoclinic, only three basal angles are needed for such calculations; when it is of rhombic symmetry, only two are necessary; and in the cases of hexagonal, tetragonal and trigonal crystals only one accurately known angle is required from which to calculate all the rest. The stereographic projection, constructed from the measurements as just described, proves an inestimable aid to these calculations, by affording a comprehensive diagram of all the spherical triangles required in making the calculations.

The relative axial lengths $a : b : c$ (in which b is always arranged to be =1), and the axial angles α (between b and c), β (between a and c), and γ (between a and b), form the "elements" of a crystal. These, together with a list of the "forms" observed, and a table of the interfacial angles, define the morphology of the crystal, and are included in every satisfactory description of a crystallographic investigation. They are preceded by a statement of the name and chemical composition and formula of the substance, the system and the class of symmetry, and the habit or various habits developed by crystals from a considerable number of crops. An example of the mode of setting out such a description will be found on pages 165 to 168.

Having thus made ourselves acquainted with the real nature of the distribution of faces on a crystal, and learnt how the crystallographer measures the angles between the faces by means of the reflecting goniometer, plots them out graphically on a stereographic projection, and calculates therefrom the "elements" of the crystal, it will be convenient again to take up the historical development of the subject so far as it relates to crystal forms and angles, and their bearing on the chemical composition of the substance composing the crystal, by introducing the reader to the great work of Mitscherlich, whose influence in the domain of chemical crystallography was as profound as that of Haüy proved to be as regards structural crystallography.

CHAPTER VIII

THE WORK OF EILHARDT MITSCHERLICH AND HIS DISCOVERY OF ISOMORPHISM

DURING the height of the French Revolution, which caused the work of the Abbe Haüy to be suspended for a time, although he was fortunately not one of the many scientific victims of that terrible period, there was born, on the 7th of January, 1794, in the village of Neuende, near Jever, in Oldenburg, the man who was destined to continue that work on its chemical side. Eilhardt Mitscherlich was the son of the village pastor, and nephew of the celebrated philologist, Prof. Mitscherlich of Göttingen. His uncle's influence appears to have given young Mitscherlich a leaning towards philological studies, for during his later terms at the Gymnasium at Jever, where he received his early education, he devoted himself with great energy to the study of history and languages, for which he had a marked talent, under the able direction and kind solicitude of the head of the Gymnasium at that time, the historian Schlosser. He eventually specialised on the Persian language, and when Schlosser was promoted to Frankfort, young Mitscherlich accompanied him, and there prosecuted these favourite studies until the year 1811, when he went to the university of Heidelberg.

For some time now he had cherished the hope of proceeding to Persia and conducting philological investigations on the spot, and in 1813, an opportunity presenting itself in the prospect of an embassy being despatched to Persia by Napoleon, he transferred himself to the university of Paris, with the object of obtaining permission from Napoleon to accompany the embassy. This visit to Paris must have been one of Mitscherlich's most exciting and interesting experiences. For Napoleon had just returned from the disastrous Russian campaign of 1812, and was feverishly engaged in raising a new army wherewith to stem the great rise of the people which was now reawakening patriotic spirit throughout the whole of Germany, and which threatened to sweep away, as it eventually did, the huge fabric of his central European Empire.

Indeed Mitscherlich appears to have been detained in Paris during the exciting years 1813 and 1814, and with the abdication

of Napoleon on April 4th of that year, he was obliged to give up all idea of proceeding to Persia. He decided that the only way of accomplishing his purpose was to attempt to travel thither as a doctor of medicine. He therefore returned to his native Germany during the summer of 1814 and proceeded to Göttingen, which was then famous for its medical school. Here he worked hard at the preliminary science subjects necessary for the medical degree, while still continuing his philology to such serious purpose as to enable him to publish, in 1815, the first volume of a history of the Ghurides and Kara-Chitayens, entitled "Mirchondi historia Thaheridarum." It is obvious from the sequel, however, that he very soon began to take much more than a merely passing interest in his scientific studies, and he eventually became so fascinated by them, and particularly chemistry, as to abandon altogether his cherished idea of a visit to Persia. Europe was now settling down after the stormy period of the hundred days which succeeded Napoleon's escape from Elba, terminating in his final overthrow on June 18th, 1815, at Waterloo, and Mitscherlich was able to devote himself to the uninterrupted prosecution of the scientific work now opening before him. He had the inestimable advantage of bringing to it a culture and a literary mind of quite an unusually broad and original character; and if the fall of Napoleon brought with it the loss to the world of an accomplished philologist, it brought also an ample compensation in conferring upon it one of the most erudite and broad-minded of scientists.

In 1818, Mitscherlich went to Berlin, and worked hard at chemistry in the university laboratory under Link. It was about the close of this year, or the beginning of 1819, that he commenced his first research, and it proved to be one which will ever be memorable in the annals both of chemistry and of crystallography. He had undertaken the investigation of the phosphates and arsenates, and his results confirmed the conclusions which had just been published by Berzelius, then the greatest chemist of the day, namely, that the anhydrides of phosphoric and arsenic acids each contain five equivalents of oxygen, while those of the lower phosphorous and arsenious acids contain only three. But while making preparations of the salts of these acids, which they form when combined with potash and ammonia, he observed a fact which had escaped Berzelius, namely, that the phosphates and arsenates of potassium and ammonium *crystallise in similar forms*, the crystals being so like each other, in fact, as to be indistinguishable on a merely cursory inspection.

Being unacquainted with crystallography, and perceiving the importance of the subject to the chemist, he acted in a very practical and sensible manner, which it is more than singular has not been

universally imitated by all chemists since his time. He at once commenced the study of crystallography, seeing the impossibility of further real progress without a working knowledge of that subject. He was fortunate in finding in Gustav Rose, the Professor of Geology and Mineralogy at Berlin, not merely a teacher close at hand, but also eventually a lifelong intimate friend. Mitscherlich worked so hard under Rose that he was very soon able to carry out the necessary crystal measurements with his newly prepared phosphates and arsenates. He first established the complete morphological similarity of the acid phosphates and arsenates of ammonium, those which have the composition $\text{NH}_4\text{H}_2\text{PO}_4$ and $\text{NH}_4\text{H}_2\text{AsO}_4$ and crystallise in primary tetragonal prisms terminated by the primary pyramid faces; and then he endeavoured to produce other salts of ammonia with other acids which should likewise give crystals of similar form. But he found this to be impossible, and that only the phosphates and arsenates of ammonia exhibited the same crystalline forms, composed of faces inclined at similar angles, which to Mitscherlich at this time appeared to be identical. He next tried the effect of combining phosphoric and arsenic acids with other bases, and he found that potassium gave salts which crystallised apparently exactly like the ammonium salts.

He then discovered that not only do the acid phosphates and arsenates of potassium and ammonium, H_2KPO_4 , $\text{H}_2(\text{NH}_4)\text{PO}_4$, H_2KAsO_4 , and $\text{H}_2(\text{NH}_4)\text{AsO}_4$ crystallise in similar tetragonal forms, but also that the four neutral di-metallic and di-ammonium salts of phosphoric and arsenic acids of the type HK_2PO_4 crystallise similarly to each other in monoclinic forms.

He came, therefore, to the conclusion that there do exist bodies of dissimilar chemical composition having the same crystalline form, but that these substances are of similar constitution, in which one element, or group of elements, may be exchanged for another which appears to act analogously, such as arsenic for phosphorus and the ammonium group (although its true nature was not then determined) for potassium. He observed that certain minerals also appeared to conform to this rule, such as the rhombohedral carbonates of the alkaline earths, calcite CaCO_3 , dolomite $\text{CaMg}(\text{CO}_3)_2$, chalybite FeCO_3 , and dialogite MnCO_3 ; and the orthorhombic sulphates of barium (barytes, BaSO_4), strontium (celestite, SrSO_4), and lead (anglesite, PbSO_4). Wollaston, who, in the year 1809, had invented the reflecting goniometer, and thereby placed a much more powerful weapon of research in the hands of crystallographers, had already, in 1812, shown this to be a fact as regards the orthorhombic carbonates (witherite, strontianite, and cerussite) and sulphates (barytes, celestite, and angle-

site) of barium, strontium, and lead, as the result of the first exact angular measurements made with his new instrument; but his observations had been almost ignored until Mitscherlich reinstated them by his confirmatory results.

While working under the direction of Rose, Mitscherlich had become acquainted with the work of Haiüy, whose ideas were being very much discussed about this time, Haiüy himself taking a very strong part in the discussion, being particularly firm on the principle that every substance of definite chemical composition is characterised by its own specific crystalline form. Such a principle appeared to be flatly contradicted by these first surprising results of Mitscherlich, and it naturally appeared desirable to the latter largely to extend his observations to other salts of different groups. It was for this reason that he had examined the orthorhombic sulphates of barium, strontium, and lead, and the rhombohedral carbonates of calcium, magnesium, iron, and manganese, with the result already stated that the members of each of these groups of salts were found to exhibit the same crystalline form, a fact as regards the former group of sulphates which had already been pointed out, not only by Wollaston, but by von Fuchs (who appears to have ignored the work of Wollaston) in 1815, but had been explained by him in a totally unsatisfactory manner. Moreover, about the same time the vitriols, the sulphates of zinc, iron, and copper, had been investigated by Beudant, who had shown that under certain conditions mixed crystals of these salts could be obtained; but Beudant omitted to analyse his salts, and thus missed discovering the all-important fact that the vitriols contain water of crystallisation, and in different amounts under normal conditions. Green vitriol, the sulphate of ferrous iron, crystallises usually with seven molecules of water of crystallisation, as does also white vitriol, zinc sulphate; but blue vitriol, copper sulphate, crystallises with only five molecules of water under ordinary atmospheric conditions of temperature and pressure. Moreover, copper sulphate forms crystals which belong to the triclinic system, while the sulphates of zinc and iron are dimorphous, the common form of zinc sulphate, $\text{ZnSO}_4 \cdot 7\text{H}_2\text{O}$, being rhombic, like Epsom salts, the sulphate of magnesia which also crystallises with seven molecules of water, $\text{MgSO}_4 \cdot 7\text{H}_2\text{O}$, while that of ferrous sulphate, $\text{FeSO}_4 \cdot 7\text{H}_2\text{O}$, is monoclinic, facts which still further complicate the crystallography of this group and which were quite unknown to Beudant and were unobserved by him. But Beudant showed that the addition of fifteen per cent. of ferrous sulphate to zinc sulphate, or nine per cent. to copper sulphate, caused either zinc or copper sulphate to crystallise in the same monoclinic form as ferrous sulphate. He also showed that all three vitriols will crystallise in mixed crystals with magnesium

or nickel sulphates, the ordinary form of the latter salt, $\text{NiSO}_4 \cdot 7\text{H}_2\text{O}$, being rhombic like that of Epsom salts.

The idea that two chemically distinct substances not crystallising in the cubic system, where the high symmetry determines identity of form, can occur in crystals of the same form, was most determinedly combated by Haüy, and the lack of chemical analyses in Beudant's work, and the altogether incorrect "vicarious" explanation given by von Fuchs, gave Haüy very grave cause for suspicion of the new ideas. The previous observations of Romé de l'Isle in 1772, Le Blanc in 1784, Vauquelin in 1797, and of Gay-Lussac in 1816, that the various alums, potash alum, ammonia alum, and iron alum, will grow together in mixed crystals or in over-growths of one crystal on another, when a crystal of any one of them is hung up in the solution of any other, does not affect the question, as the alums crystallise in the cubic system, the angles of the highly symmetric forms of which are absolutely identical by virtue of the symmetry itself.

It was while this interesting discussion was proceeding that Mitscherlich was at work in Berlin, extending his first researches on the phosphates and arsenates to the mineral sulphates and carbonates. But he recognised, even thus early, what has since become very clear, namely, that owing to the possibility of the enclosure of impurities and of admixture with isomorphous analogues, minerals are not so suitable for investigation in this regard as the crystals of artificially prepared chemical salts. For the latter can be prepared in the laboratory in a state of definitely ascertained purity, and there is no chance of that happening which Haüy was inclined to think was the explanation of Mitscherlich's results, namely, that certain salts have such an immense power of crystallisation that a small proportion of them in a solution of another salt may coerce the latter into crystallisation in the form of that more powerfully crystallising salt. Mitscherlich made a special study, therefore, of the work of Beudant, and repeated the latter observer's experiments, bringing to the research both his crystallographic experience and that of a skilful analyst. He prepared the pure sulphates of ferrous iron, copper, zinc, magnesium, nickel and cobalt, all of which form excellent crystals. He soon cleared up the mystery in which Beudant's work had left the subject, by showing that the crystals contained water of crystallisation, and in different amounts. He found what has since been abundantly verified, that the sulphates of copper and manganese crystallise in the triclinic system with five molecules of water, $\text{CuSO}_4 \cdot 5\text{H}_2\text{O}$ and $\text{MnSO}_4 \cdot 5\text{H}_2\text{O}$; in the case of manganese sulphate, however, this is only true when the temperature is between 7° and 20° , for if lower than 7° rhombic crystals of $\text{MnSO}_4 \cdot 7\text{H}_2\text{O}$ similar to those of

the magnesium sulphate group are deposited, and if higher than 20° the crystals are tetragonal and possess the composition $\text{MnSO}_4 \cdot 4\text{H}_2\text{O}$. The Epsom salts group crystallising in the rhombic system with seven molecules of water consists of magnesium sulphate itself, $\text{MgSO}_4 \cdot 7\text{H}_2\text{O}$, zinc sulphate $\text{ZnSO}_4 \cdot 7\text{H}_2\text{O}$, and nickel sulphate $\text{NiSO}_4 \cdot 7\text{H}_2\text{O}$. The third group of Mitscherlich consists of sulphate of ferrous iron $\text{FeSO}_4 \cdot 7\text{H}_2\text{O}$ and cobalt sulphate $\text{CoSO}_4 \cdot 7\text{H}_2\text{O}$, and both crystallise at ordinary temperatures with seven molecules of water as indicated by the formulæ, but in the monoclinic system. Thus two of the groups contain the same number of molecules of water, yet crystallise differently. But Mitscherlich next noticed a very singular fact, namely, that if a crystal of a member of either of these two groups be dropped into a saturated solution of a salt of the other group, this latter salt will crystallise out in the form of the group to which the stranger crystal belongs. Hence he concluded that both groups are capable of crystallising in two different systems, rhombic and monoclinic, and that under the ordinary circumstances of temperature and pressure three of the salts form most readily the rhombic crystals, while the other two take up most easily the monoclinic form. Mitscherlich then mixed the solutions of the different salts, and found that the mixed crystals obtained presented the form of some one of the salts employed. Thus even so early in his work, Mitscherlich indicated the possibility of dimorphism. Moreover, before the close of the year 1819 he had satisfied himself that aragonite is a second distinct form of carbonate of lime, crystallising in the rhombic system and quite different from the ordinary rhombohedral form, calcite. Hence this was another undoubted case of dimorphism.

During this same investigation in 1819, Mitscherlich studied the effect produced by mixing the solution of each one of the above-mentioned seven sulphates of dyad-acting metals with the solution of sulphate of potash, or ammonium, and made the very important discovery that a double salt of definite composition was produced, containing one equivalent of potassium or ammonium sulphate, one equivalent of the dyad sulphate (that of magnesium, zinc, iron, manganese, nickel, cobalt, or copper), and six equivalents of water of crystallisation, and that they all crystallised well (except potassium manganese sulphate) in similar forms belonging to the monoclinic system. Some typical crystals of one of these salts, ammonium magnesium sulphate, are illustrated in Fig. 30 (Plate VIII, facing page 30). A crystal of another salt of the series, potassium nickel sulphate, is also illustrated in Fig. 15, on page 23. This is probably the most important series of double salts known to us, and, together with the analogous and isomorphous double

selenates referred to on page 76, is the series which has formed the subject of prolonged investigation on the part of the author, no less than sixty-two different members of the series having been studied crystallographically and physically since the year 1890, the work having been completed in February, 1922. An account of this work, up to the year 1909, is given in a Monograph published in the year 1910 by Messrs. Macmillan & Co., Ltd., and entitled, "Crystalline Structure and Chemical Constitution," and the salts are brought up to the year 1921 in the second edition of the author's larger work, "Crystallography and Practical Crystal Measurement" (published by Messrs. Macmillan in March, 1922).

This remarkable record for a first research was presented by Mitscherlich to the Berlin Academy on the 9th December, 1819. During the summer of the same year, Berzelius visited Berlin, and was so struck with the abilities of Mitscherlich, then twenty-five years old, that he persuaded him to accompany him on his return to Stockholm, and Mitscherlich continued his investigations there under the eye of the great chemist. His first work at Stockholm consisted of a more complete study of the acid and neutral phosphates and arsenates of potash, soda, ammonia, and lead. He showed that in every case an arsenate crystallises in the same form as the corresponding phosphate. Moreover, in 1821 he demonstrated that sodium dihydrogen phosphate, NaH_2PO_4 , crystallises with a molecule of water of crystallisation in two different forms, both belonging to the rhombic system but with quite different axial ratios; this was consequently a similar occurrence to that which he had observed with the sulphates of the iron and zinc groups.

It was while Mitscherlich was in Stockholm that Berzelius suggested to him that a name should be given to the new discovery that analogous elements can replace each other in their crystallised compounds without any apparent change of crystalline form. Mitscherlich, therefore, termed the phenomenon "isomorphism," from *ἰσός*, equal to, and *μορφή*, shape. The term "isomorphous" thus strictly means "equal shaped," implying not only similarity in the faces displayed, but also absolute equality of the crystal angles. The fact that the crystals of isomorphous substances are not absolutely identical in form, but only very similar, was not likely to be appreciated by Mitscherlich at this time. For the reflecting goniometer had only been invented by Wollaston in 1809, and accurate instruments reading to minutes of arc were mechanical rarities. It will be shown in the sequel, as the result of the author's investigations, that there *are* angular differences, none the less real because relatively very small, between the members of such series. But Mitscherlich was not in the position to observe

them. It must be remembered, moreover, that he was primarily a chemist, and that he had only acquired sufficient crystallographic knowledge to enable him to detect the system of symmetry, and the principal forms (groups of faces having equal value as regards the symmetry) developed on the crystals which he prepared. His doctrine of isomorphism, accepted in this broad sense, proved of immediate and important use in chemistry. For there were uncertainties as to the equivalents of some of the chemical elements, as tabulated by Berzelius, then the greatest authority on the subject, and these were at once cleared up by the application of the principle of isomorphism.

The essence of Mitscherlich's discovery was, that the chemical nature of the elements present in a compound influences the crystalline form by determining the number and the arrangement of the atoms in the molecule of the compound; so that elements having similar properties, such for instance as barium, strontium, and calcium, or phosphorus and arsenic, combine with other elements to form similarly constituted compounds, both as regards number of atoms and their arrangement in the molecule. Number of atoms alone, however, is no criterion, for the five atoms of the ammonium group NH_4 replace the one atom of potassium without change of form.

This case of the base ammonia had been one of Mitscherlich's greatest difficulties during the earlier part of his work, and remained a complete puzzle until about this time, when its true chemical character was revealed. For until the year 1820 Berzelius believed that it contained oxygen. Seebeck and Berzelius had independently discovered ammonium amalgam in 1808, and Davy found, on repeating the experiment, that a piece of sal-ammoniac moistened with water produced the amalgam with mercury just as well as strong aqueous ammonia. Both Berzelius and Davy came to the conclusion that ammonia contains oxygen, like potash and soda, and that a metallic kind of substance resembling the alkali metals, potassium and sodium, was isolated from this oxide or hydrate by the action of the electric current, which Seebeck had shown facilitated the formation of the so-called ammonium amalgam. Davy, however, accepted the views of Gay-Lussac and Thénard, who, in 1809, concluded from their experiments that ammonium consisted of ammonia gas NH_3 with an additional atom of hydrogen, the group NH_4 then acting like an alkali metal, views which time has substantiated. But their further erroneous conclusion that sodium and potassium also contained hydrogen was rejected by him. Berzelius, however, set his face both against this latter fallacy and the really correct NH_4 theory, and it was not until four years after Ampère, in 1816, had shown that sal-ammoniac

was, in fact, the compound of the group NH_4 with chlorine, that Berzelius, about the year 1820, after thoroughly sifting the work of Ampère, accepted the view of the latter that in the ammonium salts it is the group NH_4 , acting as a radicle capable of replacing the alkali metals, which is present.

The fact that this occurred at this precise moment, four years after the publication of Ampère's results, leads to the conclusion that the observation of Mitscherlich, that the ammonium compounds are isomorphous with the potassium compounds, was the compelling argument which caused Berzelius finally to admit what has since proved to be the truth.

While still at Stockholm, Mitscherlich showed that the chromates and manganates are isomorphous with the sulphates, and also that the perchlorates and permanganates are isomorphous with each other. Although these facts could not be properly explained at the time, owing to the inadequate progress of the chemistry of manganese, it was seen that potassium chromate, K_2CrO_4 , contained the same number of atoms as potassium sulphate, K_2SO_4 , and that potassium permanganate KMnO_4 and perchlorate KClO_4 likewise resembled each other in regard to the number of atoms contained in the molecule.

As a good instance of the use of the principle of isomorphism, we may recall that when Marignac, in 1864, found himself in great difficulty about the atomic weights of the little-known metals tantalum and niobium which he was investigating, he discovered that their compounds are isomorphous; the pentoxides of the two metals occur together in isomorphous mixture in several minerals, and the double fluorides with potassium fluoride, K_2TaF_7 and K_2NbF_7 , are readily obtained in crystals of the same form. The specific heat of tantalum was then unknown, so that the law of Dulong and Petit connecting specific heat with atomic weight could not be applied, and the vapour density of tantalum chloride, as first determined by Deville and Troost with impure material, did not indicate an atomic weight for tantalum which would give it the position among the elements that the chemical reactions of the metal indicated. Yet Marignac was able definitely to decide, some time before the final vapour density determinations were made by Deville and Troost with pure salts, from the fact of the isomorphism of their compounds, that the only possible positions for tantalum and niobium were such as corresponded with the atomic weights 180 and 93 respectively. Time has only confirmed this decision, and we now know that niobium and tantalum belong to the same family group of elements as that to which vanadium belongs, and the only difference which modern research has introduced has been to correct the decimal places of the atomic weights,

that of niobium (now more properly called columbium, Cb, the name given to it by its discoverer, Hatchett, in 1801) being now accepted as 92.8 and that of tantalum 179.6, when that of hydrogen=1.

Applying the law of isomorphism in a similar manner, Berzelius was enabled to fix the atomic weights of copper, cadmium, zinc, nickel, cobalt, iron, manganese, chromium, sulphur, selenium, and chlorine, the numbers accepted to-day differing only in the decimal places, in accordance with the more accurate results acquired by the advance of experimental and quantitative analytical methods. But with regard to several other elements, owing to inadequate data, Berzelius made serious mistakes, showing how very great is the necessity for care and for ample experimental data and accurate measurements before the principle of isomorphism can be applied with safety. Given these, and we have one of the most valuable of all the aids known to us in choosing the correct atomic weight of an element from among two or three possible alternatives. We are only on absolutely sure ground when we are dealing not only with a series of compounds consisting of the same number of atoms, but when also the interchangeable elements are the intimately related members of a family group, such as we have since become familiar with in the vertical groups (and same odd or even series) of elements in the periodic table of Mendeléeff (Appendix III).

Before leaving Stockholm, Mitscherlich showed, from experiments on the crystallisation of mixtures of the different sulphates with which he had been working, that isomorphous substances in general intermix in crystals in all proportions (certain limitations will be dealt with in Chapter XI), and that they also replace one another in minerals in indefinite proportions, a fact which has of recent years been wonderfully exemplified in the cases of the hornblende (amphibole) and augite (pyroxene) groups.

In November, 1821, Mitscherlich closed these memorable labours at Stockholm and returned to Berlin, where he acted as extraordinary professor of the university until 1825, when he was elected professor in ordinary. His investigations for a time were largely connected with minerals, but on July 6th, 1826, he presented a further most important crystallographic paper to the Berlin Academy, in which he announced his discovery of the fact that one of the best known chemical elements, sulphur, is capable of crystallising in two distinct forms. The ordinary crystals found about Etna and Vesuvius and in other volcanic regions agree with those deposited from solution in carbon bisulphide in exhibiting rhombic symmetry, as shown in Fig. 104, Plate XIX, facing page 150. But Mitscherlich found that when sulphur is fused and allowed to cool until partially solidified, and the still liquid portion

is then poured out of the crucible, the walls of the latter are found to be lined with long monoclinic prisms. These have already been illustrated in Fig. 2, Plate I, facing page 2, in Chapter I.

Here was a perfectly clear case of an element—not liable to any suspicion of difference of chemical composition such as might have applied to the cases of sodium dihydrogen phosphate, carbonate of lime, or iron vitriol and its analogues, which he had previously described as cases of the same substance crystallising in two different forms—which could be made to crystallise in two different systems of symmetry at will, by merely changing the circumstances under which the crystallisation occurred. His explanation being thus proved absolutely, he no longer hesitated, but at once applied the term “dimorphous” to these substances exhibiting two different forms, and referred to the phenomenon itself as “dimorphism.” The case of carbonate of lime had given rise to prolonged discussion, for the second variety, the rhombic aragonite, had been erroneously explained by Stromeyer, after Mitscherlich’s first announcement in 1819, as being due to its containing strontia as well as lime, and the controversy raged until Buchholz discovered a specimen of aragonite which was absolutely pure calcium carbonate, so that Mitscherlich’s dimorphous explanation was fully substantiated.

Dimorphism is very beautifully illustrated by the case of the trioxide of antimony, Sb_2O_3 , a slide of which, obtained by sublimation of the oxide from a heated tube on to the cool surface of a glass microscope-slip, is seen reproduced in Fig. 55, Plate XIII. The two forms are respectively rhombic and cubic. The rhombic variety usually takes the form of long needle-shaped crystals, which are shown in Fig. 55 radiating across the field and interlacing with one another; the cubic variety crystallises in octahedra, of which several are shown in the illustration, perched on the needles, one interesting individual being poised on the end of one of the needles. The two forms occur also in nature as the rhombic mineral valentinite and the cubic mineral senarmontite, which latter crystallises in excellent regular octahedra. Antimonious oxide, moreover, is not only isomorphous, but isodimorphous with arsenious oxide, a slide of octahedra of which has already been reproduced in Fig. 3, Plate I, in Chapter I. For besides this common octahedral form of As_2O_3 artificial crystals of arsenious oxide have been prepared of rhombic symmetry, resembling valentinite. Hence the two lower oxides of arsenic and antimony afford us a striking case of the simultaneous display of Mitscherlich’s two principles of isomorphism and dimorphism.

Thus the position in 1826 was that Mitscherlich had discovered the principle of isomorphism, and had also shown the occurrence of dimorphism in several well-proved specific cases, and that he

regarded at this time isomorphism as being a literal reality, absolute identity of form.

These striking results appeared at once to demolish the theory that any one substance of definite chemical composition is characterised by a specific crystalline form, which was Haiiy's most important generalisation. Mitscherlich, however, soon expressed doubts as to the absolute identity of form of his isomorphous crystals, and saw that it was quite possible that, in the systems other than the cubic (in which latter system the highly perfect symmetry itself determines the form, and that the angles shall be identically constant), there might be slight distinctive differences in the crystal angles. For he caused to be constructed, by the celebrated optician and mechanic, Pistor, the most accurate goniometer which had up till then been seen, provided with four verniers, each reading to ten seconds of arc, and with a telescope magnifying twenty times, for viewing the reflections of a signal, carried by a collimator, from the crystal faces. Unfortunately in one respect, he was almost at once diverted, by the very excess of refinement of this instrument, to the question of the alteration of the crystal angles by change of temperature, and lost the opportunity, never to recur, of doing that which would at once have reconciled his views with those of Haiiy in regard to this important matter, namely, the determination of these small but real differences in the crystal angles of the different members of isomorphous series, and the discovery of the interesting law which governs them, a task which in these later days has fallen to the lot of the author.

Another remarkable piece of crystallographic work, this time in the optical domain, which has rendered the name of Mitscherlich familiar, was his discovery of the phenomenon of crossed-axial-plane dispersion of the optic axes in gypsum. (The nature and meaning of "optic axes" will be explained in Chapter XV, page 183.) During the course of a lecture to the Berlin Academy in the year 1826, Mitscherlich, always a brilliant lecturer and experimenter at the lecture table, exhibited an experiment with a crystal of gypsum (selenite) which has ever since been referred to as the "Mitscherlich experiment." He had been investigating the double refraction of a number of crystalline substances at different temperatures, and had observed that gypsum, hydrated calcium sulphate, $\text{CaSO}_4 \cdot 2\text{H}_2\text{O}$, was highly sensitive in this respect, especially as regards the position of its optic axes. At the ordinary temperature it is biaxial, with the two optic axes separated at an angle of about 60° . But on heating the crystal the angle diminishes, until about 10° below the temperature of boiling water the axes become identical, as if the crystal were uniaxial, and then they again separate as the temperature rises further, but in the plane



FIG. 50.—Ammonium Chloride crystallizing from a Labile Supersaturated Solution (see p. 49)



FIG. 55.—Rhombic Needles and Cubic Octahedra of Antimony Trioxide obtained by Sublimation. An interesting Example of Dimorphism

REPRODUCTIONS OF PHOTOMICROGRAPHS

To face p. 72

at right angles to that which formerly contained them; hence the phenomenon is spoken of as "crossed-axial-plane dispersion." Mitscherlich employed a plate of the crystal cut perpendicularly to the bisectrix of the optic axial angle, and showed to the Academy the interference figures (see Plate XIV) which it afforded in convergent polarised light with rising temperature. At first, for the ordinary temperature, the usual rings and lemniscates surrounding the two optic axes were just apparent at the extreme right and left margins of the field; as the crystal was gently heated (its supporting metallic frame being heated with a spirit lamp) the axes themselves at the centres of the two series of rings came into view and approached each other, with ever changing play of colour and alteration of shape of the rings and lemniscates, until eventually the dark hyperbolic brushes, marking by their well-defined vertices the positions of the two optic axes within the innermost rings, united in the centre of the field to produce the uniaxial dark rectangular cross; the rings around the centre had now become circles, the lemniscates having first become ellipses which more and more approximated, as the temperature rose, to circles. Then the dark cross opened out again, and the axial brushes separated once more, but in the vertical direction, and the circles became again first ellipses and then lemniscates, eventually developing inner rings around the optic axes; if the source of heat were not removed at this stage the crystal would suddenly decompose (about 120° C.), becoming dehydrated, and the field on the screen would become dark. If, however, the spirit lamp were removed before this occurred, the phenomena were repeated in the reverse order as the crystal cooled.

This beautiful experiment is now frequently performed, as gypsum is perhaps the best example yet known which exhibits the phenomenon of crossed-axial-plane dispersion by change of temperature alone. A considerable number of other cases are known, such as brookite, the rhombic form of titanium dioxide TiO_2 , and the triple tartrate of potassium, sodium, and ammonium, but these are more sensitive to change of wave-length in the illuminating light than to change of temperature.

The author, in the year 1908, exhibited the "Mitscherlich experiment" to the Royal Society¹, and also in his Evening Discourse to the British Association at their 1909 meeting in Winnipeg, in a new and more elegant manner, employing the large Nicol-prism projection polariscope shown in Fig. 56, and a special arrangement of lenses for the convergence of the light, which is so effective that no extraneous heating of the crystal is required. The convergence of the rays is so true on a single spot in the centre of the crystal

¹ *Proc. Roy. Soc.*, 1908, A, 81, 40.

plate about two millimetres diameter, that a crystal plate not exceeding 6 mm. is of adequate size, mounted in a miniature holder-frame of platinum, or brass, with an aperture not more than 3 mm. ; the thickness of the crystal should remain about 2 mm., in order that the rings round the axes may not be too large and diffuse, the crystal being endowed with very feeble double refraction, which is one of the causes of the phenomenon. Such a small crystal heats up so rapidly in the heat rays accompanying the converging light rays—even with the essential cold water cell two inches thick placed between the lantern condenser and the polarising Nicol, for the protection of the balsam of the latter—that any

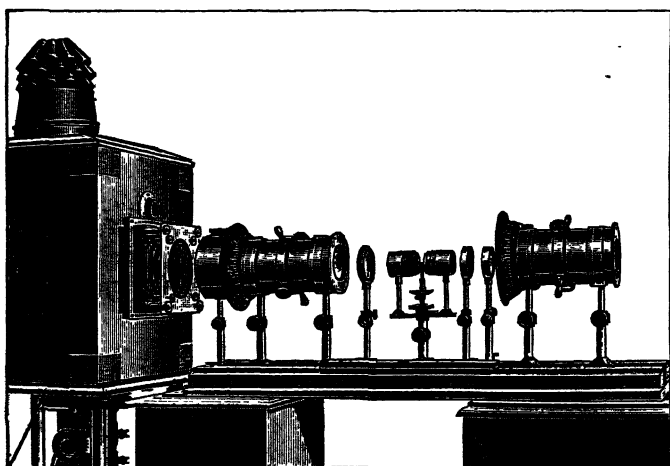

FIG. 56.—The Mitscherlich Experiment with Gypsum.

extraneous heating by a spirit or other lamp is entirely unnecessary. The moment the electric arc of the lantern is switched on, the optic axial rings appear at the right and left margins of the screen, when the crystal is properly adjusted and the arc correctly centred, and they march rapidly to the crossing point in the centre, where the dark hyperbolæ unite to produce the rectangular St. Andrew's cross, the rings, figure-eight curves, and other lemniscates passing through the most exquisite evolutions and colour changes all the time until they form the circular Newton's rings, around the centre of the cross ; after this the cross and circles again open out, but along the vertical diameter of the illuminated field on the screen, into hyperbolæ and rings and loop-like lemniscates surrounding two axes once more. It is wise as soon as the separation in this plane is complete and the first or second separate rings have appeared round the axes, to arrest the heating by merely interposing inter-

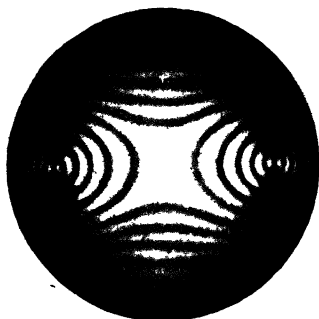

FIG. 57.—Appearance of the Interference Figure half a Minute after commencing the Experiment. Temperature of Crystal about 40° C.

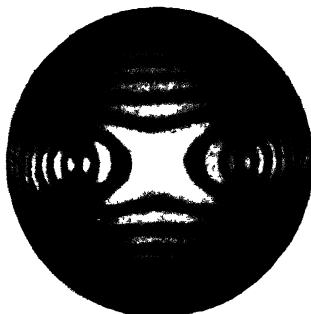

FIG. 58.—Appearance a Minute or so later, the Axes approaching the Centre. Temperature of Crystal about 75° C.

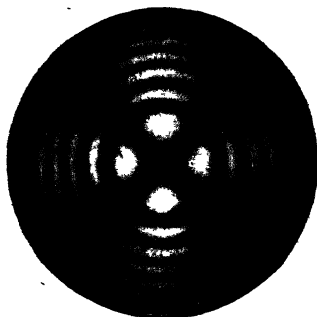

FIG. 59.—The Two Optic Axes coincident in the Centre of the Figure, two or three Minutes from the commencement. Temperature of Crystal 91° C.

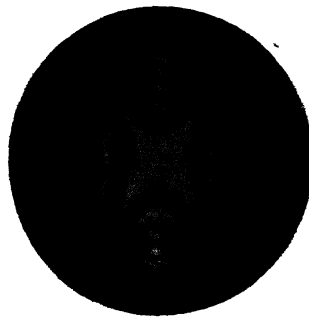

FIG. 60.—The Axes re-separated in the Vertical Plane a Minute or two later. Temperature of Crystal about 115° C.

THE MITSCHERLICH EXPERIMENT WITH GYPSUM

FOUR STAGES IN THE TRANSFORMATION OF THE INTERFERENCE FIGURE IN CONVERGENT POLARISED LIGHT, FROM HORIZONTALLY BIAxIAL THROUGH UNIAxIAL TO VERTICALLY BIAxIAL, ON RAISING THE TEMPERATURE TO 115° C.

(From Photographs by the author.)

mittently a hand screen between the lantern and polariser, or by blowing a current of cool air past the crystal, which will cause the axes to recede again, and the phenomena to be reversed, the crossing point being repassed, and the axes brought into the original horizontal plane again. By manipulation of the hand screen, or air-current, the axes can thus be caused to approach or to recede from the centre at will, along either the horizontal or vertical diameter. Four characteristic stages of the experiment are shown in Figs. 57 to 60, Plate XIV. Fig. 57 exhibits the appearance shortly after commencing the experiment, the optic axes being well in the field of view. Fig. 58 shows the axes horizontally approaching the centre. Fig. 59 shows the actual crossing, which occurs for different wave-lengths of light at temperatures varying from $88^{\circ}1$ (for violet G-light) to $91^{\circ}0$ (for yellow light of wave-length, 0.000573 mm.); and Fig. 60 represents the axes again separated, but vertically. The fact of the maximum crossing temperature of 91° C. being for yellow light of the particular wave-length just mentioned, is connected with the interesting fact that the optic axial angle of gypsum has a maximum for this specific wave-length of light. The uniaxial cross is formed for yellow sodium light at $90^{\circ}9$, for green thallium light at $90^{\circ}8$, for red hydrogen C-light at $90^{\circ}4$, for red lithium light at $90^{\circ}2$, and for greenish-blue F-hydrogen light at $90^{\circ}1$ C.

The experiment as thus performed is one of the most beautiful imaginable, and it can readily be understood how delighted was Mitscherlich's audience on the occasion of its first performance by him. The author has since discovered no less than six other cases of substances which exhibit crossed-axial-plane dispersion of the optic axes, in the course of his investigations, one of which is illustrated in Plate XV, facing page 82; and, moreover, has arrived at a general explanation of the whole phenomenon, the main points of which are that such substances, besides showing very feeble double refraction (the two extreme of the three refractive indices being very close together), also exhibit very close approximation of the intermediate refractive index β to either the minimum index a or the maximum index γ . Also, change of temperature, or of wave-length, or most usually both, must so operate as to bring the two indices closest together into actual identity and then to pass beyond each other, these two indices thus exchanging positions, the extreme one becoming the intermediate index. In other words, the uniaxial cross and circular rings are produced owing to two of the three refractive indices (corresponding to the directions of the three rectangular axes of the ellipsoid which, in general, expresses the optical properties of a crystal) becoming equal at the particular temperature at which the phenomenon is observed to occur, and

for light of the specific wave-length in question. The ellipsoid of general form which represents the optical properties of a biaxial crystal thus becomes converted into a rotation ellipsoid corresponding to a uniaxial crystal. Brookite and the triple tartrate are excellent examples of the predominance of the effect of change of wave-length, for the optic axes are separated in both cases widely in one plane for red light and almost equally widely in the perpendicular plane for blue light. The new cases observed by the author are sensitive both to change of wave-length and to change of temperature, and so fall midway between the cases just quoted and the case of gypsum. The cause of it, in four of these new instances, is a very interesting one, connected with the regular change of the refractive indices in accordance with the law of progression in an isomorphous series according to the atomic weight and atomic sequence number of the alkali metal present, which will be discussed in Chapter XI.

A further most important discovery was made by Mitscherlich in the year 1827, which also profoundly concerns the work of the author, namely, that of selenic acid, H_2SeO_4 , analogous to sulphuric acid, and of the large group of salts derived from it, the selenates, analogous to the sulphates. He showed first that potassium selenate, K_2SeO_4 , is isomorphous with potassium sulphate, K_2SO_4 , and subsequently that the selenates in general are isomorphous with the corresponding sulphates; consequently it followed that selenium is a member of the sulphur family of elements. This element selenium had only been discovered ten years previously by his friend, Berzelius, and doubtless Mitscherlich had seen a great deal of the work in connection with it during the two years which he spent in the laboratory of Berzelius at Stockholm, and was deeply interested in it.

The discovery has proved a most fruitful one, for the selenates are beautifully crystalline salts, particularly suitable for crystallographic researches, and their detailed investigation, and that of the double selenates analogous to the double sulphates referred to on page 66, has afforded a most valuable independent confirmation of the important results obtained for the sulphates and double sulphates.

Again in 1830, Mitscherlich, following up the preliminary work already referred to, definitely established another fact bearing on the same series, namely, the isomorphism of potassium manganate K_2MnO_4 with the sulphate and selenate of potash; moreover, on continuing his study of the manganese salts he further substantiated the isomorphism of the permanganates with the perchlorates, and isolated permanganic acid. This also proved a most important step forward, as these salts likewise afford admirable material for

crystallographic investigation, and such an examination, carried out by Muthmann and Barker, has yielded most valuable results.

Much later in his career, Mitscherlich also described the dimorphous iodide of mercury, HgI_2 , one of the most remarkable and interesting salts known to us, the unstable yellow rhombic modification being converted into the more stable red tetragonal form by merely touching with a hard substance. Also we are indebted to him at the same later period for our knowledge of the crystalline forms of the elements phosphorus, iodine, and selenium, when crystallised from solution in bisulphide of carbon.

From the record of achievements which has now been given in this chapter, it will be obvious how much chemical crystallography owes to Mitscherlich. The description of his work has taken us into almost every branch of the subject, morphological, optical, and thermal, and although it has consequently been necessary to refer to phenomena which have not yet been explained in this book, it has doubtless proved on the whole most advantageous thus to present the life-work of this great master as a complete connected story.

CHAPTER IX

MORPHOTROPY AS DISTINCT FROM ISOMORPHISM

It has been shown in the last chapter how Mitscherlich discovered the principle of isomorphism, as applying to the cases of substances so closely related that their interchangeable chemical elements are members of the same family group; and also how the principle enabled him to determine the chemical constitution of two hitherto unknown acids which he isolated, selenic H_2SeO_4 and permanganic HMnO_4 . For he observed that the selenates were isomorphous with the sulphates, and the permanganates with the perchlorates. It was further made clear that the principle as bequeathed to us by Mitscherlich was only defined in very general terms, and its details have only recently been precisely decided.

Before proceeding further (in Chapter XI) with the elucidation of the true nature of isomorphism, however, some important crystallographic relationships between substances less closely related than family analogues must be referred to, as the outcome of a series of investigations by von Groth, chiefly between the derivatives of the hydrocarbon benzene. Also, some suggestive results obtained by the author from an investigation of an organic homologous series, that is, one the members of which differ by the regular addition of a CH_3 group, may be briefly referred to.

The interval between the work of Mitscherlich and that of von Groth was one of doubt, discouragement, and somewhat of discredit for chemical crystallography. The chemists Laurent¹ and Nicklès² carried out during the years from 1842 to 1849 measurements of numerous organic substances and of some inorganic compounds, the former chiefly halogen or other derivatives of particular hydrocarbons or salts of homologous fatty acids. Laurent, for instance, found that naphthalene tetrachloride, $\text{C}_{10}\text{H}_8\cdot\text{Cl}_4$, and chloronaphthalene tetrachloride, $\text{C}_{10}\text{H}_7\text{Cl}\cdot\text{Cl}_4$, crystallise in different systems, the former in the monoclinic and the latter in the rhombic system. Yet the primary prism angles of the two are less than a degree different, namely, $109^\circ 0'$ and $109^\circ 45'$. Laurent named this kind of similarity "hemimorphism," a most unfortunate term as it was

¹ *Comptes Rendus*, 1842, 15, 350, and 1845, 20, 357.

² *Ibid.*, 1848, 27, 611, and 1849, 29, 339.

already employed in crystallography in its other well-known geometrical significance, that is, to denote a crystal differently terminated at the two ends of an axis. Many other like similarities were discovered by Laurent, and he again coined an objectionable term, now discarded, to represent the cases of similarity extending over more than the same system, namely, "isomeromorphism."

Nicklès observed similar facts in connection with the barium salts of the fatty acids, which crystallise in different systems with different amounts of water of crystallisation. But their prism angles are all within a couple of degrees of each other, varying from 98° to 100° . Thus the phenomenon of "isogonism," a term much less objectionable than those invented by Laurent, appears to be a common observance not only for different kinds of derivatives of the same original hydrocarbon or other organic nucleus, but also for the case of homologous series. But Nicklès missed the real point by including salts with different amounts of water, which, it will be shown later, entirely upset the crystalline structure. When this is eliminated the resemblance between true similarly constituted homologues, differing by regular increments of CH_2 , is very much closer than would appear from Nicklès' results.

Unfortunately, some of the work of Laurent and Nicklès was not carried out with the care and accuracy which is indispensable for researches which are to retain permanent value, and critics were not slow to arise. Kopp,¹ in 1849, unmercifully exposed these failings, so that the real kernel of the work, which was of considerable value, came into discredit.

Pasteur, however,² in 1848, besides the important observations regarding enantiomorphism, to be described in Chapter XIV, had noticed similar zonal likenesses between related tartrates, amounting only therefore to isogonism and not to isomorphism; for here again the system often differed, particularly when the members of a series compared differed in their water of crystallisation. Thus there was ample evidence of a really significant series of facts in the work of these authors, but they were not properly arranged and explained.

So high was the feeling against the whole subject carried, however, after Kopp's memoir, that had it not been for the steadying influence of Rammelsberg and Marignac, who themselves carried out many crystallographic measurements as new substances continued to be discovered with great rapidity, the science would have suffered a serious set-back. Moreover, even Rammelsberg was led astray in the direction of the views of the chemists of the time, that isomorphism could be extended over the crystal system. Frankenheim, whose discovery of the space-lattice, to be referred

¹ *Jahresbericht*, 1849, 19.

² *Comptes Rendus*, 1848, 26, 535.

to in the next chapter, will ever render his name famous, strongly opposed this view. Delafosse, on the other hand, recognised some truth in both views, and assumed that there were two kinds of isomorphism, that of Mitscherlich on the one hand, and the broader one of Laurent on the other hand, and that in the case of the latter kind the overstepping of the system is no bar.

Hjortdahl,¹ in the year 1865, supported the views of Delafosse more or less, at any rate so far as to assume the possibility of the existence of partial isomorphism, that is, of isogonism. He was very definite, however, against accepting the proposition that any general law could be applied. He himself discovered a partial similarity of angles in several homologous series of organic compounds.

About this time Sella² uttered a warning which is one worthy of being prominently posted in every research laboratory, namely, that *It is unwise to make hasty generalisations from the results of a small number of observations.* Were this principle more generally followed, much greater progress would in the end be achieved, and without the discouragement and discredit which inevitably follows the detection of errors due to lack of broad experimental foundation. It is certainly an incontrovertible fact that only such generalisations as find themselves in accordance with all new but well-verified experimental facts as they are revealed can stand the test of time and become accepted universally as true laws of nature. And it is unreasonable to expect any generalisation to be of such a character unless it is already based on so large a number of facts that there is little fear of other new ones upsetting them.

Some order was, however, introduced into this chaotic state of chemical crystallography in the year 1870 by P. von Groth.³ He investigated systematically the derivatives of the hydrocarbon benzene, C_6H_6 , many of which are excellently crystallising solids suitable for goniometrical measurement. He showed that although the crystal system may be and often is altered, yet there is a striking similarity in the angles between the faces of certain zones, which for the purposes of comparison he arranged to be parallel to each other in his descriptions of the crystals, so that the relationship would then consist in an elongation or a shortening of this particular zone axis, which was usually a crystallographic axis. He recognised that this was a totally different phenomenon from isomorphism, and called it "morphotropy." Although it may possibly be permissible from one point of view to regard isomorphism as a particular case of complete morphotropy along all zones, such a

¹ *Journ. für Prakt. Chemie*, 1865, **94**, 286.

² *Mem. R. Accad. di Torino*, 2A, **17**, 337, and **20**, 255.

³ *Pogg. Ann.*, **141**, 31.

course is not advisable, as morphotropic similarities are frequently of a comparatively loose and often indeed of a somewhat vague character, while isomorphous relationships are governed by very precise laws.

Thus von Groth showed first that benzene, C_6H_6 , crystallises in the rhombic system with axial ratios $a : b : c = 0.891 : 1 : 0.977$. Next, that when one or two of the hydrogen atoms are replaced by hydroxyl OH groups the substances produced, phenol $C_6H_5 \cdot OH$ and resorcinol $C_6H_4(OH)_2$, are found also to crystallise in the rhombic system, and in the second case, for which alone the axial ratios could be determined, the ratio $a : b$ proved to be very similar, but the ratio $c : b$ was different, the actual values being $a : b : c = 0.910 : 1 : 0.540$. Pyrocatechol, the isomer (same empirical composition) of resorcinol, also crystallises in the rhombic system, but the crystals have not been obtained sufficiently well formed to enable any deductions to be made from any measurements carried out with them.

Similarly, the nitro-derivatives of phenol, orthonitrophenol $C_6H_4 \cdot OH \cdot NO_2$, dinitrophenol $C_6H_3 \cdot OH \cdot (NO_2)_2$, and trinitrophenol $C_6H_2 \cdot OH \cdot (NO_2)_3$, also crystallise in the rhombic system, and with the following respective axial ratios: $0.873 : 1 : 0.60$; $0.933 : 1 : 0.753$; $0.937 : 1 : 0.974$. Again, the value for the ratio $a : b$ is not very different from that of benzene itself, while the ratio $c : b$ differs considerably in the first two cases. Similar relations were also found to hold good in the cases of meta-dinitrobenzene, $C_6H_4(NO_2)_2$, axial ratios $0.943 : 1 : 0.538$, and trinitrobenzene, $C_6H_3(NO_2)_3$, which possesses the axial ratios $0.954 : 1 : 0.733$.

The introduction of a chlorine or bromine atom or a CH_3 group in place of hydrogen was found by von Groth to produce more than the above effect, the symmetry being often lowered to monoclinic, a fact which had also been observed to occur in the cases of certain isomers of the substances quoted above, ortho-dinitrobenzene for instance. But it was nevertheless observed that the angles between the faces in the prism zone remained very similar, the angles between the faces of the primary prism (110) and $\bar{1}\bar{1}0$, for instance, only varying in eight such derivatives of all three types, whether rhombic or monoclinic, from $93^\circ 45'$ to $98^\circ 51'$.

The crystallographic relationships of organic substances, however, are very much complicated by the possibilities of isomerism; the ortho, meta, and para compounds—corresponding to the replacement of the two hydrogen atoms attached to two adjacent, alternate, or opposite carbon atoms respectively, of the six forming the benzene ring—generally differing extensively and sometimes completely in crystalline form. Consequently, the phenomenon of morphotropy is best considered quite independently of isomorphism.

An interesting intermediate case between morphotropy and true

isomorphism was investigated by the author in the year 1890, namely, a series of homologous organic compounds differing by regular increments of the organic radicle CH_2 . They were prepared by Prof. Japp and Dr. Klingemann, and consisted of the methyl,

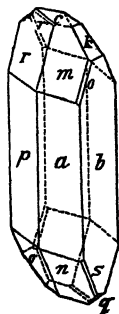

FIG. 61.
Crystal of
Methyl
Triphenyl
Pyrrolone.

CH_3 , ethyl, C_2H_5 , and propyl, C_3H_7 , derivatives of the substance triphenyl pyrrolone, all of them being solids crystallising well. The problem was somewhat complicated by the development of polymorphism, the methyl, ethyl, and propyl compounds having each been found to be dimorphous, and not improbably trimorphous, but only two varieties of each salt were obtained in crystals adequately perfect for measurement. That the production of these different forms was due to polymorphism and not to chemical isomerism (different arrangement of the chemical atoms in the molecule) was shown by the fact that one variety could be obtained from the other by simply altering the conditions of crystallisation from the same solvent. Their identical chemical composition was established by direct analysis.

The methyl (CH_3) compound¹ crystallised in rhombohedra and in triclinic prisms. The ethyl (C_2H_5) derivative was deposited in triclinic prisms exactly resembling those of the methyl compound in habit and disposition of faces. A crystal of the triclinic methyl derivative which would represent equally well the ethyl compound is shown in Fig. 61. The angles also of the crystals of the two substances are so similar that one might infer the existence of true and complete isomorphism. The actual angular differences rarely exceeded three degrees.

Besides the triclinic form the ethyl derivative was also obtained in monoclinic crystals, one of which is represented in Fig. 62. This illustration might serve equally well, however, for a corresponding monoclinic form of the propyl (C_3H_7) derivative, and the angles of these two monoclinic ethyl and propyl compounds are even closer than those of the triclinic methyl and ethyl derivatives, the closeness increasing with the advent of symmetry.

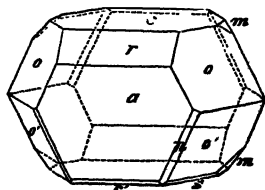
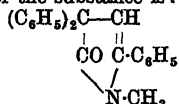

FIG. 62.—Crystal of Ethyl
Triphenyl Pyrrolone.

¹ The constitutional formula of the substance is:—



In the ethyl and propyl compounds the CH_3 at the foot of the formula is replaced by C_2H_5 and C_3H_7 , respectively.



FIG. 63.—Interference Figures in Convergent Polarised Light of different Wave-lengths afforded by the Monoclinic Variety of Ethyl Triphenyl Pyrrolone; *a*, in Red Lithium Light; *b*, in Yellow Sodium Light; *c*, in Greenish-Yellow Light of the Critical Wave-length 0.000575 mm. for Production of the Uniaxial Figure; *d*, in Green Thallium Light; *e*, in mixed Sodium and Thallium Light; and *f*, in White Light

(Reproductions of Drawings by the author.)

This similarity of angles in the cases of the two pairs of triclinic and monoclinic compounds is not only true about particular zones, but about all the zones, so that it is a case of isomorphism rather than of isogonism (morphotropy). The similarity of optical properties is also very close, and so much so in the cases of the monoclinic crystals of ethyl and propyl triphenyl pyrrolone that both exhibit very high dispersion of the optic axes. In the case of the propyl derivative the difference between the apparent angle in air of the optic axes for red lithium light and for green thallium light amounts to 11° . In the case of the ethyl compound this difference is enhanced so considerably that the crystals afford a remarkable instance of dispersion of the optic axes in crossed axial planes, resembling the case of gypsum discovered by Mitscherlich and described in the last chapter, except that the sensitiveness is to change of wave-length in the illuminating light rather than to change of temperature. The optic axial plane is perpendicular to the symmetry plane for lithium and sodium light, as it is also in the case of the propyl compound; but in the ethyl derivative it crosses over for thallium light and rays beyond that towards the violet, into a plane at right angles to the former plane, namely, the symmetry plane itself. The total dispersion between the two axes as separated in the one plane for red light, and as separated in the other perpendicular plane for blue light, is more than 70° . Fig. 63, Plate XV, shows the nature of the interference figures afforded in convergent polarised light of different wave-lengths by a section-plate perpendicular to the first median line. The figure at *f* represents what is observed in white light, as far as is possible by a drawing in black and white. It consists of a series of concave coloured curves, falling in between the arms of the cross, and looping round the axes, a figure very much like that afforded by brookite and triple tartrate of ammonium, potassium, and sodium, the substances already mentioned in Chapter VIII as being similarly very sensitive to change of wave-length. The figure in red monochromatic lithium light is shown at *a* in Fig. 63, and that for yellow sodium light at *b*, the axes being now much closer together. On changing to green thallium light the line joining the optic axes becomes vertical instead of horizontal, as shown at *d*.

When, instead of employing monochromatic flames, the spectroscopic monochromatic illuminator (Fig. 118, page 188), described by the author some years ago to the Royal Society,¹ is employed to illuminate the polariscope, the source of light being the electric arc, the change of the figure from that given by the extreme red of the spectrum to that afforded by the violet may be beautifully followed, and the exact wave-length in the greenish yellow determined for

¹ Phil. Trans. Roy. Soc., A, 1895, 185, 913.

which the crossing occurs and an apparently uniaxial figure of circular rings and rectangular cross is produced. For it is possible with the aid of this illuminator directly to observe the production of the uniaxial figure. The wave-length is either directly afforded by the graduation of the fine-adjustment micrometric drum or is obtained from a curve of wave-lengths, constructed to correspond to the circle readings of the illuminator. The appearance of the interference figure for this critical wave-length is shown at *c* in Fig. 63, and a series of careful determinations showed that the wave-length in question is 0.000575 mm. in the slightly greenish yellow. The remaining figure at *e* represents the appearance when a mixture of sodium and thallium light is employed, which clearly indicates the four oppositely disposed axial positions for these two colours of light, and assists in elucidating the nature of the figure *f* exhibited in white light.

The second form of the propyl derivative belongs to the rhombic system, and a similar rhombic form of the ethyl compound was once obtained, but lost again on attempting to recrystallise.

These interesting relationships of the homologous methyl, ethyl, and propyl derivatives of triphenyl pyrrolone thus appear to form a connecting link between cases of isogonism or morphotropy and of true isomorphism.

We are now, therefore, in a position to approach the question of true isomorphism, and as leading up to the fuller treatment of the subject in Chapter XI we may conclude this chapter by referring first to one important investigation in which the necessity for extreme accuracy of measurement and perfection of material was fully appreciated. This was an admirable research carried out in the years 1887 and 1888 by H. A. Miers¹ (now Sir Henry Miers) on the red silver minerals, proustite, sulpharsenite of silver, Ag_3AsS_3 , and pyrargyrite, the analogous sulphantimonite of silver, Ag_3SbS_3 , which afforded a further indication of the existence of real small differences of angle between the members of truly isomorphous series. These two minerals form exceptionally beautiful crystals belonging to the trigonal system, the hexagonal prism being always a prominent form, terminated by the primary and other rhombohedra, scalenohedra and various pyramidal forms, many of the crystals being exceedingly rich in faces. When the crystals are freshly obtained from the dark recesses of the silver mine they are very lustrous and transparent, but they are gradually affected by light, like many silver compounds, and require to be stored in the dark in order to preserve their transparency. A magnificent crystal of proustite from Chili is one of the finest objects in the British Museum at South Kensington, but is rarely seen on account

¹ *Mineralogical Magazine*, 1888, 8, 37.

of the necessity for preservation from light. Pyrargyrite is generally dark grey in appearance, and affords a reddish-purple "streak" (colour of the powder on scratching or pulverising). Proustite, however, possesses a beautiful scarlet-vermilion colour, and affords a very bright red streak.

Now these two beautiful minerals are obviously analogous compounds of the same metal, silver, with the sulpho-acid of two elements, arsenic and antimony, belonging strictly to the same family group, the nitrogen-phosphorus group V, and the analogous odd series 5 and 7, of the periodic classification of the elements according to Mendeléeff (Appendix III). Consequently, they should be perfectly isomorphous. Sir Henry Miers has shown in a most complete manner that they are so, that they occur in very perfect crystals of similar habit belonging to the same class of the trigonal system, the ditrigonal polar class, both minerals being hemimorphic, that is, showing different forms at the two terminations, in accordance with the symmetry of the polar class of the trigonal system. But the angles of the two substances were not found to be identical although constant for each compound within one minute of arc, there being slight but very real differences, which are very well typified by the principal angle in each case, that of the primary rhombohedron. In the case of proustite it is $72^{\circ} 12'$, while the rhombohedron angle of pyrargyrite is $71^{\circ} 22'$.

This interesting and beautiful investigation of Sir Henry Miers thus gave us an inkling of the truth, that small angular differences do exist between the members of isomorphous compounds. It paved the way for, and, indeed, partly suggested, the author's systematic investigation of the sulphates, selenates, and double salts of the alkali series of metals, a brief account of the main results of which will be given in Chapter XI.

CHAPTER X

THE NATURE OF ATOMS. THE UNITS OF CRYSTAL STRUCTURE.
THE CRYSTAL SPACE-LATTICE AND ITS MOLECULAR OR POLY-
MOLECULAR UNIT CELL. THE 230 POINT-SYSTEMS OF HOMO-
GENEOUS CRYSTAL STRUCTURE.

THE interval between the morphotropic work described in the last chapter and the present time has been remarkable for the completion of the geometrical and mathematical investigation, and the successful identification, of all the possible types of homogeneous structures possessing the essential attributes of crystals. It has now been definitely established that there are 230 such types of homogeneous structures possible, and the whole of them conform to the conditions of symmetry of one or other of the thirty-two classes of crystals. This fact is now thoroughly agreed upon by all the authorities who have made the subject their special study, and may truly be considered as fundamental.

There has long been a consensus of opinion that the crystal edifice is built up of structural units which can be likened to the bricks or stone blocks of the builder, but which in the case of the crystal are so small as to be invisible even under the highest power of the microscope. The conceptions of their nature, however, have been almost as numerous as the investigators themselves, everyone who has thought over the subject forming his own particular ideas concerning them. We have had the "Molécules intégrantes" of Haüy, the "Polyhédres" of Bravais, the "Fundamentalbereich" of Schoenflies, the "Parallelohedra" of Fedorov, and the fourteen-walled cell, the "Tetrakaidecahedron" of Lord Kelvin, and again the "Polyhedra" of Pope and Barlow. Ideas have thus been extremely fertile, and indeed almost every variety of speculation has been indulged in as to the shape and nature of the unit of the structure which can exhibit such remarkable evidences of organisation and such extraordinary optical and other physical properties as those of a crystal.

There is one inherent difficulty, however, which accounts largely for the great variety of conception possible. It is this, that the matter of the molecules, and again that of the atoms composing them, is certainly not continuous and in contact throughout, but

that on the contrary the space which may legitimately be assigned to the unit of the structure is partly void. How much of this unit space is matter and how much is unoccupied, and how the one is related to the other as regards its position or distribution in space, are distinct problems of great difficulty and the deepest interest. The brilliant work during the last decade of Sir J. J. Thomson and his school of physicists, and of Sir Ernest Rutherford, Bohr, Van der Broek and Moseley, has rendered it clear, however, that the chemical atom is composed of a positively charged nucleus surrounded by negatively electrified planetary "electrons," or electronic corpuscles, held in equilibrium by the forces from the nucleus, and the orbital or other motions of which determine the boundaries of the atom. The exceptionally interesting work of Moseley has revealed the very important fact that the positive electric charge on the nucleus is directly represented by the atomic number, the sequence number of the element according to its position in the periodic table. Further, it has proved that the atomic number is also identical with the number of the negative electrons which surround the nucleus planetarily, in cycles or shells, when the number gets more than a very few.

The planetary electrons occupy rather than fill a region the diameter of which, according to Sir Ernest Rutherford, is of the order 2×10^{-8} cm. The dimensions of the sphere of impenetrability of the atoms of the various elements have, however, now been definitely ascertained within very narrow limits, as the result of the X-ray analysis of crystals to be referred to in Chapter XII. Moreover, the cycles or shells of electrons correspond to the periods of the periodic law of the elements, the tabular representation of which is given at the end of the book in Appendix III. The successive shells are completed when the atoms of the inert gases, helium, neon, argon, krypton, xenon, and niton are produced, the very fact of the shell being complete being the explanation of the remarkable lack of chemical affinity exhibited by these elements.

Starting with the lightest element, hydrogen, the first of the periodic table, and therefore of atomic (sequence) number 1, the atoms of this element possess a nucleus with a positive charge of one unit, and with one attendant negative electron. The next element, helium, of atomic number 2, has a positive charge of two units and two attendant negative electrons. These two gases alone form the first period, and it is a remarkable fact that the nuclei of the atoms of all other elements are now known to be built up of hydrogen and helium nuclei and electrons, and further, that the helium nucleus itself is a secondary unit composed of four hydrogen nuclei and two electrons, so that the nuclei of all atoms are composed ultimately of hydrogen nuclei, with the addition of

negative electrons. Hence, the hydrogen nucleus, which has been termed in consequence a "proton," is the ultimate unit of matter, as was long ago suggested by Prout.

The next element after helium, lithium, of atomic number 3, begins a new cycle or shell, with a nucleus of positive charge 3 and 3 negative electrons; then we have in order beryllium, boron, carbon, nitrogen, oxygen, fluorine, and neon, with respective atomic numbers, positive charges and planetary electrons 4, 5, 6, 7, 8, 9 and 10, the atoms of the inert gas, neon, completing the period or series, thus having two complete planetary shells around the nucleus, the inner one of two electrons and the outer one of eight. The third period, series, or octave, of eight elements begins with sodium and ends with the inert atmospheric gas, argon, of atomic number 18, which has a third complete shell of eight electrons, making 18 electrons in all. The fourth period begins with the alkali metal potassium, of atomic number, charge, and electrons 19, and it appears to include two series of elements, a double octave, of 18 electrons, for the next inert gas, krypton, does not come at the end of series 4 but at the close of series 5, with the atomic number 36, so that this fourth shell must have 18 electrons. A similar thing occurs with the next period beginning with the alkali metal rubidium of atomic number 37, for the next inert gas of the argon family, xenon, comes at the end of two more series, with the atomic number 54, so that the fifth shell also has 18 electrons. Finally, the next period beginning with the last and most powerful alkali metal cesium, of atomic number, positive nuclear charge, and number of negative electrons 55, includes four series, or a quadruple octave, the next and last inert gas, niton, having the atomic number charge and electrons 86, this shell thus possessing no less than 32 electrons. But this last long period includes two series of rare-earth elements, and it may be, there being considerable evidence, that the atoms of these elements are not formed in the ordinary manner by the addition of electrons to the outer shell, but by internal addition of electrons.

The version of the atomic structure theory which has been given, and which assumes successive shells of 2, 8, 8, 18, 18, and 32 electrons, is the most recent one due to G. N. Lewis and I. Langmuir, which will be shown in the Chapter XII on X-ray analysis of crystals to fit the crystallographic facts best. But the original version, due to N. Bohr and A. Sommerfeld, while agreeing on all the main facts with the new version, assumes that there is a fresh cycle or shell for each period-series of eight or ten elements of the periodic table as given in Appendix III, except during the formation of the two periods of rare earths beginning with cerium, no electrons being added to the exterior, but only internally, until we arrive at

the element tantalum, when the ordinary procedure is resumed. The two versions will doubtless before long be reconciled, and indeed the most recent work of Sir J. J. Thomson is tending to that consummation.

Now the most interesting fact of all is that the electrons of the outer shell of the atom determine the chemical properties of the element, and they are frequently alluded to as valency electrons, and indeed have been even considered as roving or movable ones. But the new version of the structure theory takes the view that when the shell is complete, as in the case of the inert gas atoms, the chemical affinity is *nil* because there is a state of satisfaction, whereas when there are less than the complete number of electrons in the shell energy in the form of chemical affinity is displayed by more or less powerful attempts to acquire the complete number, either by taking them from other atoms able to part with them, or by giving up electrons to other atoms able to receive them. What direction the energy takes appears to depend on whether the shell is already more than half or less than half completed. For instance, the alkali metals, potassium, rubidium, and caesium, come next after an inert gas in each case, and thus have only one electron in the outer shell, and the very strongest electropositive chemical affinity is displayed owing to the readiness with which this one extra electron is parted with when a suitable other atom capable of absorbing it is adjacent. On the other hand, just such an atom is that of any one of the halogen elements, chlorine, bromine, or iodine, which has one electron short of a complete shell in its outer coat, as it immediately precedes an inert gas in the periodic series. Consequently, a chlorine atom, for example, when brought into adequate proximity to a potassium atom, takes up the extra electron of the latter with the greatest avidity possible, thereby completing its own shell and leaving the potassium atom likewise with a complete outer shell. But in so doing, and producing atoms with 18 electrons each like argon, the potassium atom of atomic number and positive charge 19 is no longer a neutral body but is left with an excess of one unit of positive charge, while the chlorine atom of atomic number and positive charge 17 is no longer also neutral, but has now one unit excess of negative charge. Hence, electrostatic attraction occurs between the two atoms and they form the chemical compound potassium chloride, KCl, in which the two atoms are held together as closely as their outer shells, atomic domains of impenetrability, or spheres of influence permit, such atomic domain being that the diameter of which will be shown in Chapter XII to have been ascertained by the X-ray analysis of the solid crystal of the compound substance.

Similarly, the atom of the dyad electropositive element, calcium

has two electrons only in its outer shell, while that of the dyad electronegative element, oxygen, has two less than the full number for a complete inert gas shell, and so here again combination occurs, by the transference of the two extra or valency electrons of the calcium atom to the oxygen atom. On the other hand, two electronegative elements, such as carbon and oxygen, are supposed in the Lewis-Langmuir version to combine by the sharing of pairs (duplets) of their outer electrons, this type of combination being a very close one, the two atoms being very intimately bound together, while the compound resulting from the combination of an electropositive with an electronegative element occupies more space.

The periodic law of Newlands and Mendeléeff, which has been the greatest mystery of modern chemistry, is thus now wonderfully explained. The brilliant researches of Moseley, moreover, have definitely fixed the order and positions of all the chemical elements in the table, as well as their sequence numbers, the atomic numbers; and they have also shown that there are only 92 possible elements, up to and including uranium, which has this atomic number, and that all of them are known except five, for which vacant places are awaiting the day of their discovery. The mass or weight constant of the atom, the atomic weight—which relates entirely to the nucleus, the negative electrons having no appreciable weight or mass (only $1/1840$ of the mass of the hydrogen atom), and on which so much skill, care, and labour has been expended in order to fix it for each of the elements with accuracy—with the exception of the unit case of hydrogen, is generally in the neighbourhood of twice the atomic number. In the table given in Appendix III the heavy numbers are the atomic numbers and the italic numbers the atomic weights when oxygen is 16.00. It has recently been found that there may be two or more varieties of atoms of the same element, which have been denominated "isotopes," and which have the same nuclear charge (equal to the atomic number), but different nuclear masses, and therefore slightly different atomic weights, the difference being about two or three units as a rule, but sometimes as much as six between the extremes where there are several isotopes. Lead, for instance, which has been derived by radio-active change from uranium, has an atomic weight of 206, while lead derived similarly from thorium has the higher atomic weight 208. Ordinary lead appears to be a mixture of the two varieties, for its atomic weight is about the mean, 207.

The two radio-active changes which have been referred to are of great interest. For uranium slowly disintegrates into three atoms of helium and an atom of radium; radium, in turn, the most radio-active of the three best known radio-active elements on the

verge of instability, breaks up into one atom of helium and one atom of a gaseous emanation, which appears to be an isotope of niton; and finally, this emanation disintegrates into four atoms of helium and one of lead. Again, thorium disintegrates directly into six atoms of helium and one atom of lead. Thus the ultimate products of all this radio-activity appear to be helium and lead. During the spontaneous disintegration of radium the helium atoms lose their negative electrons (β -particles), which are thus liberated and resemble those generated in the Crookes' tube, and like those electrons they also produce radiations of the character of X-rays, the γ -rays.

Since this remarkable work concerning the atomic weight of lead, and the fact also derived therefrom that the radium emanation was an isotope of niton, one of two possible varieties of the element, F. W. Aston has shown by means of a remarkable series of researches with a mass spectrograph for positive rays produced in a special form of Crookes' tube, that many of the better known and more volatile or gaseous chemical elements as we know them are mixtures of two or more isotopes, which accounts for the slightly different atomic weights often found for the same element derived from different sources. On the other hand, hydrogen, helium, carbon, nitrogen, oxygen, fluorine, phosphorus, sulphur, arsenic and iodine are single elements (no isotopes), and it is remarkable that for all these elements the atomic weights are whole numbers, except hydrogen, which has the exact atomic weight 1.008.

To effect any permanent change in an element by artificial means (for all the radio-active changes which have been referred to are naturally spontaneous) the nucleus itself must be disrupted. The spontaneous changes naturally occurring in the cases of the radio-active metals are entirely due to the fact of their complexity having reached the verge of instability, these elements being those of maximum atomic number and mass. This spontaneous disruption consists, as just described, of the emission from the nucleus of swift so-called α particles, which are helium nuclei (atoms without the two electrons which are emitted separately as already shown). Sir Ernest Rutherford, however, early in the year 1922, succeeded in artificially causing the disruption of nitrogen atoms by bombarding them with these α -particles, the result having been to detach hydrogen nuclei from the nitrogen atoms, thus affording a direct proof that hydrogen is the ultimate unit of matter. The nitrogen nucleus would thus appear to be built up of three helium nuclei of total mass 12 and two hydrogen nuclei of total mass 2.015 (when oxygen=16.00); the nitrogen atom should thus be of mass 14.01, as found by chemical methods. Moreover, by firing α -particles into the atoms of quite a number of other elements, he

has been able to discover, from the deflections suffered by the α -particles, the magnitude and law of the forces in the neighbourhood of the nucleus, and the dimensions of the latter. The law of inverse squares is found to hold fairly well, and in the case of heavy atoms the nuclear dimensions are of the order 4×10^{-12} cm., or only 1/5000th of the diameter of the whole atom-structure, while in the case of a light atom, such as helium, it is only 5×10^{-13} cm.

Somewhat later in the same year (May, 1922), Sir Ernest Rutherford effected the disruption of the atoms also of boron, fluorine, sodium, aluminium and phosphorus by bombarding them with the swift α -particles expelled from radium, swift hydrogen nuclei being discharged from the nuclei of the atoms bombarded in each case. Aluminium behaved in a particularly interesting manner, for nearly as many hydrogen atoms were shot backwards as forwards in the direction of the colliding α -particles.

The α -particle (helium nucleus) expelled from radium is the most concentrated source of energy known, and the only one capable of attacking with any success such stable structures as atomic nuclei, which are held together by such powerful forces; it alone, by its collision with the atomic nuclei of the six elements mentioned, is able to break them up. The disintegration, however, is on an extremely minute scale, for only about two α -particles in every million approach near enough to the nucleus to dislodge a hydrogen particle. If all the α -particles from one gramme of radium were fired into aluminium, only one-thousandth of a cubic millimetre of hydrogen could be liberated in a year.

The α -particle or helium nucleus of mass 4 has already, like hydrogen, been shown to be one of the units of which atoms are built up. Now it is interesting that hydrogen particles are only liberated by α -particles from elements of the masses, $4n+2$ or $4n+3$, where n is a whole number. Elements such as carbon and oxygen, the atomic masses of which are $4n$, give off no hydrogen particles. So the former elements must have in their constitution helium nuclei of mass 4 and hydrogen nuclei of mass 1.008, the latter probably as close and strongly bound satellites.

Moreover, all these six disruptible elements possess odd atomic numbers, namely, 5, 7, 9, 11, 13, and 15; and W. D. Harkins has shown that the elements of odd atomic number are much less stable than those of even atomic number. These facts would appear to account for this remarkable disruption of the six elements in question.

It has been essential to refer to these experimental facts, which are fundamental, and in any case of fascinating interest, concerning the nature of the chemical atoms, and which are entirely the product of the last decade of research, in order that any approach to a correct

appreciation of the nature and ultimate structure of crystals may be attained.

As regards the distribution of the atoms in the molecule in the solid state, that is, the positions of the various elementary atoms in the unit cell of the space-lattice, which is occupied by a single chemical molecule, or a small group (four, for instance, as in the rhombic alkali sulphates) of molecules, we are now obtaining a considerable amount of definite information from the new X-ray analysis of crystal structure, to which a special chapter (XII) is devoted later on in the book. This is an entirely new field of research of vast interest and importance, which we owe to the initial discovery of Laue, that the almost infinitesimally short wave-length of the X-rays renders them capable of being reflected by the planes of atoms in a crystal, the order of the wave-length being similar to the order of atomic dimensions.

It will have become clear from these facts concerning the nature and structure of atoms, that there are large empty spaces (relatively) within the atom; yet the outer shells of electrons are not penetrable by other atoms, so that the outer shell of electrons may be regarded as the "Sphere of Influence" of the atom, and it will be shown in Chapter XII that the diameter of this sphere has actually been determined by X-ray analysis, in the cases of a considerable number of the chemical elements.

It may now be quite definitely stated, moreover, that the unit of the space-lattice of the crystal structure is either the chemical molecule itself, or a very small aggregation of chemical molecules, such as two, three, or four molecules, this fact concerning the grosser structural unit, that of the Bravais space-lattice, having been proved very fully by the development of the X-ray analysis which we owe to Prof. Sir W. H. Bragg and his school of workers.

Fortunately, however, there is no necessity whatever to introduce the subject of the actual shape or size of the atomic ultimate unit of the crystal structure, and great progress had already been effected before the discovery of X-ray methods by disregarding it altogether, and agreeing to the representation of the unit by a point. This leads us at once to perceive the importance of the brilliant work of the geometers, who long before the discovery of Laue had completed their theory of the homogeneous partitioning of space into point-systems possible to crystals, the structural units of the latter being regarded as points. The work of the investigators by means of X-rays has so remarkably confirmed the work of the crystallographic geometer, that the story of the completion of the geometrical theory of crystal structure is one of the deepest and almost romantic interest. The investigations extend from those of Frankenheim in the year 1830 to the finishing

touches given by Barlow in 1894, and prominently standing forth as those of the greatest contributors to the subject, besides the two investigators just mentioned, are the names of Bravais, Sohncke, Schoenflies and Fedorov.

Bravais, perfecting the work of his predecessor, Frankenheim, made us acquainted with the fourteen fundamentally important space-lattices, or same-ways orientated arrangements of points. If we regard each chemical molecule, or small group of molecules, the grosser crystal-structural-unit, as represented by a point, disregarding the separate atoms (ultimate structural units) of which it is composed, then these fourteen space-lattices represent the possible arrangements of the grosser structural units in the crystal; three of these lattices have cubic symmetry; the tetragonal, hexagonal, trigonal, rhombic and monoclinic systems claim two space-lattices each; while one space-lattice conforms to the lack of symmetry of the triclinic system.

The fourteen space-lattices of Bravais thus represent the arrangement of the chemical molecules, or polymolecular groups, in the crystal, and determine the systematic symmetry. The points being taken absolutely analogously in all the molecules, or groups,

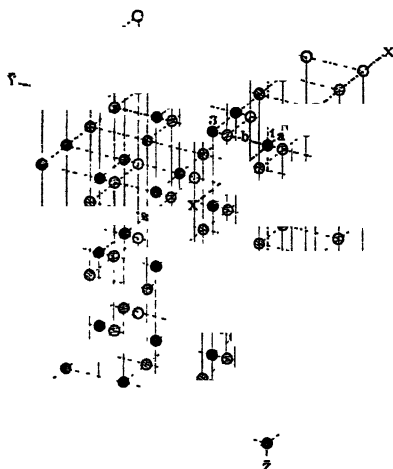

FIG. 64.—Triclinic Space-Lattice.

one from each to represent it, and the whole assemblage being homogeneous, that is, such that the environment about any one point is the same as about every other, the arrangement is obviously a same-ways orientated one, the molecules, or groups, being all arranged parallel-wise to each other.

But the fact that the structure is that of a space-lattice also causes the crystal to obey the law of rational indices. To enable us to see how this comes about it is only necessary to regard a space-lattice. In Fig. 64 is represented the general form of space-lattice, that which corresponds to triclinic symmetry. It is obviously built up of parallel-epipeda, the edges of which are proportional to the lengths of the three triclinic axes, and their mutual inclinations are those of the latter. As we may take our representative point anywhere in the molecule (or group of molecules) so long as the position chosen is the same for all the molecules, or groups, of the assemblage,

we may imagine the points occupying the centres of the parallel-epipeda instead of the corners if we choose, for that would only be equivalent to moving the whole space-lattice slightly parallel to itself. Hence, each cell may be regarded as the habitat of the chemical molecule, or of the small group of two, three, or four molecules which compose the grosser structural unit.

Now the faces of the crystal parallel to each two of the three sets of parallel lines forming the space-lattice will be the three pairs of axial-plane faces, and any fourth face inclined to them must be got by removing parallelepipedal blocks in stepwise fashion, precisely like bricks, as already shown in Fig. 12 (page 18) in Chapter III, in order to illustrate the step by step removal of Haüy's unit blocks. It will readily be seen that if one more cell be removed from each row than from the row below it, the line of contact touching the projecting corner of the last block of each row will be inclined more steeply than if two more cells were removed from each row. Moreover, the angle varies considerably between the two cases, and if three blocks are removed at a time the angle gets very small indeed. Hence, there cannot be many such planes possible, and we see at once why the indices of the faces developed on a crystal are composed of low whole numbers and why the forms are so relatively few in number. Owing to the minuteness of a chemical molecule, all the irregularities of such a surface are submicroscopic, and the general effect to the eye is that of a smooth plane surface.

The space-lattice arrangement of the molecules or polymolecular groups in the crystal structure thus causes the crystal to follow the law of rational indices, by limiting and restricting the number of possible facial forms which can be developed. It also determines which one of the seven systems of symmetry or styles of crystal architecture the crystal shall adopt. It does not determine the details of the architecture, however, that is, to which of the thirty-two classes it shall conform, this not being the function of the molecular or polymolecular arrangement (that of the grosser structural units), but of the atomic arrangement, that is, of the arrangement of the cluster of atoms which form the molecule, and of the several molecules forming the group if the grosser unit be polymolecular (in other words, of the ultimate structural units), and this leads us to the next step in the unravelling of the internal structure of crystals.

The credit of this next stage of further progress is due to Sohncke, whose long labours resulted in the discrimination and description of sixty-five "Regular Point-Systems,"¹ homogeneous assemblages

¹ Figures illustrating each of these sixty-five point-systems will be found in Vol. I of the author's *Crystallography and Practical Crystal Measurement* (Macmillan and Co.), Second Edition, 1922.

of points symmetrically and identically arranged about axes of symmetry, which are sometimes screw axes, that is, axes about which the points are spirally distributed. Sohncke's point-systems express the number of ways in which symmetrical repetition can occur. Moreover, the points may always be grouped in sets or clusters, the centres of gravity of which form a Bravais space-lattice. Also in some instances a space-lattice is a special case of one of the sixty-five point-systems.

These latter facts are of great interest, for they mean that Sohncke's points may represent the chemical atoms, and that the stereometric arrangement of the atoms in the molecule is that which produces the point-system and determines the crystal class, while the whole cluster of atoms forming the molecule (or a group of molecules) furnishes, as above stated, in its representative point (say, centre of gravity), a point of the space-lattice.

This, however, is not the whole story, for the sixty-five Sohnckian regular point-systems only account for twenty-one of the thirty-two crystal classes, the remaining eleven being those which are not only of lower than full holohedral systematic symmetry, but which are also characterised by showing complementary right and left-handed forms. In other words, they exhibit two varieties, on one of which faces, often of low symmetry, are developed on the right, while on the other symmetrically complementary faces are developed on the left; that is, these little faces modify on the right and left respectively the solid angles formed by those faces of the crystal which are common to both the holohedral class of the system and to the lower symmetry class in question. In some cases, moreover, these two complementary forms are known to exist alone, without the presence of faces common to both the holohedral class and the class of lower symmetry. The two varieties of the crystals are the mirror images of each other, being related as a right-hand glove is to a left-hand one.

Further, the crystals of these eleven classes very frequently exhibit the power of rotating the plane of polarised light to the right or to the left, and complementarily in the cases of the two varieties of any one substance, corresponding to the complementarity of the two crystal forms. The converse is even more absolute, for no optically active crystal has yet been discovered which does not belong to one or other of these eleven classes of lower than holohedral symmetry.

The final step of accounting for the structure of these highly interesting eleven classes of crystals was taken simultaneously by a German, Schoenflies, a Russian, Fedorov, and an Englishman, Barlow, who quite independently and by totally different lines of reasoning and of geometrical illustration showed that they were

entirely accounted for by the introduction of a new element of symmetry, that of mirror-image repetition, or "enantiomorphous similarity" as distinguished from "identical similarity." These three investigators all united in finally concluding that when the definition of symmetrical repetition is thus broadened to include enantiomorphous similarity, 165 further point-systems are admitted, and the whole 230 point-systems then account for the whole of the thirty-two classes of crystals.

Schoenflies' simple definition of the nature of the structure is that every molecule is surrounded by the rest collectively in like manner, when likeness may be either identity or mirror-image resemblance. Fedorov finds the extra 165 types to be comprised in "double systems," consisting of two "analogous systems" which are the mirror images of each other. Barlow proceeds to find in how many ways the two mirror-image forms can be combined together, there being in general three distinct modes of duplication, including the insertion of one inside the other. He also shows that all homologous points in a structure of the type of one of these additional 165 point-systems together form one of the sixty-five Sohnckian point-systems, the structure being capable of the same rotations or translations, technically known as "coincidence movements" (movements which bring the structure to exhibit the same appearance as at first), as those which are characteristic of that point-system. Moreover, the sixty-five point-systems of Sohncke involve only such coincidence movements as are of what are termed the first class, consisting of rotations and translations; whereas the further 165 point-systems involve coincidence movements of the second class, which include mirror-reflection (across a plane).

This fascinating subject of mirror-image symmetry, and the optical activity connected with it, will be reverted to and the latter explained in Chapter XIV.

We have thus seen how satisfactorily the geometrical theory of the homogeneous partitioning of space has been worked out, and how admirably it agrees with our preliminary supposition that a crystal is a homogeneous structure. The fact that the 230 homogeneous point-systems all fall into and distribute themselves among the thirty-two classes of crystals, the symmetry of which has also now been fully established, affords undeniable proof that as regards this branch of the subject something like finality and clearness of vision has now been arrived at. We may accept this with all the more confidence, as it has since been confirmed so absolutely by the remarkable new mode of investigating crystals by means of X-rays, as will be shown conclusively in Chapter XII.

CHAPTER XI

LAW OF VARIATION OF ANGLES IN ISOMORPHOUS SERIES. RELATIVE DIMENSIONS OF UNIT CELLS. FIXITY OF ATOMS IN CRYSTAL

WE are now in a position to approach the conclusion of the long controversy as to the constancy or otherwise of crystal angles in the cases of greatest similarity, those of isomorphous substances, and to appreciate how the conflicting views of Haüy and Mitscherlich and their schools of thought have at length been reconciled. As the result of the comprehensive study by the author, already referred to on page 67, of the sulphates and selenates of the rhombic series $R_2\overset{S}{\text{Se}}\text{O}_4$, and of the double sulphates and selenates of the monoclinic series $R_2M(\overset{S}{\text{Se}}\text{O}_4)_2 \cdot 6\text{H}_2\text{O}$, in which R represents the alkali metals, potassium, rubidium and caesium, and in which M may be magnesium, zinc, iron, nickel, cobalt, manganese, copper or cadmium, four facts of prime significance have been definitely established.¹

(1) The crystals of the different members of an isomorphous series exhibit slight but real and quite definite differences in their interfacial angles, the magnitude of the angle changing regularly with the alteration of the atomic weight and atomic number of the interchangeable metals or negative elements of the same family group which give rise to the series, as one metal or acid-forming element is replaced by another. The amount of the difference increases as the symmetry of the system diminishes. Thus the maximum difference for the more symmetrical rhombic series of sulphates and selenates is $56'$, which occurs in the case of one angle between potassium and caesium selenates, and it is usually much less than this; in the case of the less symmetrical monoclinic series of double salts the maximum angular difference observed was $2^\circ 28'$, between potassium and caesium copper selenates.

(2) The physical properties of the crystals, such as their optical and thermal constants, are also functions of the atomic weights

¹ It should be remembered that the atomic weights ($H=1$) of the alkali metals are: $K=38.85$, $Rb=84.9$, and $Cs=131.9$, and therefore that $Rb-K=46$ and $Cs-Rb=47$. The atomic numbers of K, Rb, and Cs are 19, 37, and 55, so that $Rb-K=18$ and $Cs-Rb=18$. The differences for the two interchanges are therefore equal in the cases of both constants.

and atomic numbers of the elements of the same family group which by their interchange produce the series.

(3) The dimensions of the elementary parallelepipedon of the space-lattice, or in other words, the distances of separation of the molecular or polymolecular centres of gravity, the points or nodes of the space-lattice, along the three directions of the crystal axes, also vary with the atomic weight and atomic number of the interchangeable elements.

(4) Specific chemical replacements are accompanied by clearly defined changes in the crystal structure along equally specific directions. Thus, when the metal, say potassium, in an alkali sulphate or selenate is replaced by another of the same alkali-family group, rubidium or caesium, there is a marked alteration in the crystal angles and in the dimensions of the space-lattice, corresponding to elongation of the vertical axis; and when the acid-forming element sulphur is replaced by selenium, its family analogue, a similar very definite change occurs, but the expansion in this case takes place in the horizontal plane of the crystals.

Confirmatory results have also been obtained as regards the morphological constants, the investigations not extending to the optical or thermal properties, by Muthmann for the permanganates, and by Barker for the perchlorates, of the alkali metals. Hence, there can be no doubt whatever that, as regards the various series investigated, which are such as would be expected to afford the most definite results owing to the electro-positive nature of metals being at its maximum strength in the alkali group, the above rules are definite laws of nature.

Thus it is clear that in the cases of isomorphous substances, which were the only possible exceptions to the generalisation that *to every chemically distinct solid substance of other than perfect cubic symmetry there appertains a specific crystalline form, endowed with its own particular angles and morphological crystal elements, which are absolutely constant for the same temperature*, the law does really hold, and isomorphous substances are no exceptions. The law of progression of the crystal properties according to the atomic weight and atomic sequence number of the interchangeable elements affords, indeed, at the same time both an amplification of the generalisation and a precise explanation of its mode of operation in these cases.

The discovery of the local effect produced by the two kinds, positive and negative, of chemical replacement, has a profound bearing on crystal structure. For it is thereby rendered certain that the atoms are fixed in the crystal edifice, and therefore in the molecule in the solid state. It becomes obvious that the atoms—in their stereometric positions in the molecule, being thus fixed in

the solid crystal when the molecules set themselves rigidly in the regular organisation of the space-lattice—form the points of the regular point-system of the crystal structure, which determines to which of the thirty-two classes of symmetry the crystal shall belong. Any movement of the atoms in the crystal, other than the very limited one which accompanies change of temperature, and possibly change of pressure, is thus improbable; and this experimental proof of their fixity, afforded by the fact that definitely orientated changes accompany the replacement of particular atoms, also doubtless indicates that the latter are located in the particular directions along which the changes of exterior angle and of internal structural dimensions are observed to occur. Stereo-chemistry, which has made such enormous advances during the last few years, thus becomes of even greater importance than Wislicenus and its other originators ever dreamt of.

Within the atoms in the crystal the constituent negative electrons may be and probably are in rapid movement about the positive nucleus, and such physical effects as have hitherto been ascribed to movement of the atoms within the crystal are doubtless due to movement of the electrons within them, the sphere of influence of the atom itself being fixed in space in the solid crystal, and being doubtless defined by the area within which the electronic movements occur.

According to the Lewis-Langmuir version of the atomic structure theory, however, the movements of the electrons do not occur in

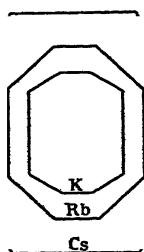

FIG. 65.—Diagram illustrating Progressive Change of Crystal Angles in Isomorphous Series.

the wide orbits assumed in the Bohr-Sommerfeld version, but are restricted about particular symmetrical positions on the shells to which they belong, such, for instance as about the eight corners of a cube.

Three illustrations of the law of change of the crystal properties with variation of the atomic weight and atomic number of the determinative elements of an isomorphous series may be given, and will serve to render the practical meaning of the generalisation clearer. The first is a diagrammatic representation, in Fig. 65 (in a very exaggerated manner as the real change would be inappreciable on the scale drawn), of the change of angle on replacing the potassium in potassium sulphate, K_2SO_4 , or selenate, K_2SeO_6 , by rubidium or cæsium. The inner crystal outline, a vertical section, is that of the potassium salt. The vertical lines represent the intersections of the two faces of the brachypinakoid $b = \{010\}$ with a vertical plane parallel to the (paper and the) macropinakoid $a = \{100\}$; the

horizontal lines represent the intersection of the two faces of the basal plane $c=\{001\}$ with the same vertical plane; and the oblique lines represent the intersection of the vertical plane with the four faces of the dome form $q=\{011\}$, which are inclined to both b and c planes. The diagram is thus designed to show the variation of the inclination of these latter dome faces to the two rectangular axial plane faces b and c . The outer crystal outline represents a similar section of a crystal of the corresponding caesium salt, and the middle outline that of a crystal of the rubidium salt.

The progressive alteration of the angle of the q -face will be obvious, the direction of the change being correct, but the amount of change, as already stated, being much exaggerated; in reality it never reaches a degree between the two extreme (potassium and caesium) salts. It will be remembered that the respective atomic weights of potassium, rubidium, and caesium are 38.85, 84.9 and 131.9, when hydrogen equals 1, that of rubidium being almost exactly the mean.

The value of any particular angle in the case of the crystals of any rubidium salt, of either the rhombic simple sulphate and selenate series, or the monoclinic double sulphate and selenate series, is always intermediate between the values of the same angle on the crystals of the corresponding potassium and caesium salts. The exact position for the rubidium salt is not generally precisely midway, but in the case of the important axial angle β of the monoclinic series, which is the same as the angle between the basal pinakoid $c(001)$ and the orthopinakoid $a(100)$, the position is truly halfway, so that the changes of this angle for the two replacements are directly proportional to the two changes in the atomic weights or atomic numbers of the interchangeable alkali metals. Also, which is even more interesting, when all the changes of the 36 or 37 different interfacial angles for the replacement of potassium by rubidium and of potassium by caesium are tabulated and their mean taken, the mean of the second replacement is found to be exactly double that for the first replacement, just as the change in atomic weight and number is double (93 to 46 and 36 to 18). So that the average change of angle is also directly proportional to the change of atomic weight or number.

Moreover, the maximum change of angle (the largest in the list) is likewise directly proportional to the change of atomic weight or number. These rules are followed with remarkable precision by the monoclinic double salt series, for which the changes are much larger, and therefore more clearly apparent, and much further removed from the limits of possible error in measurement due to slight distortion of the crystals.

The second illustration is taken from the optical properties.

Fig. 66 represents graphically the regular diminution of double refraction (the difference between the two extreme indices of refraction α and γ) which accompanies increase of the atomic weight and atomic number of the metal present. The diagram exhibits the closing up of the two spectra afforded by three analogously orientated 60° -prisms, one of each of the three salts, such as was used in determining two (in this case α and γ) of the three (α , β , and γ) refractive indices of the salt. Each prism produces two refracted rays from the single ray furnished by the collimator of the spectrometer, and consequently two images of the signal-slit of the collimator when monochromatic light is used, or two spectra if white light be employed, one corresponding to α and the other to γ . The

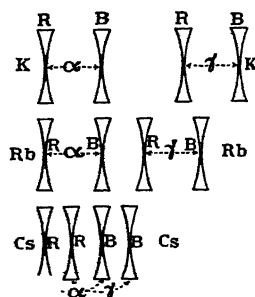

FIG. 66.—Diagram illustrating Progressive Change of Double Refraction in Isomorphous Series.

of the latter, coloured monochromatic light of each of the two colours in turn and of the exact C and F wave-lengths having been fed to the spectrometer from the spectroscopic illuminator (described on page 187). It will be observed in the case of the top row that the two spectra, each indicated by the adjacent red and greenish-blue images linked together by a dotted line and arrows, are well apart, the relative distance being about that actually observed in the case of potassium sulphate. They are nearer together, however, in the second row, which indicates what is observed in the case of the analogous rubidium salt, and in the lowest row representing the relative distances of the two spectra apart in the case of the caesium salt, they are so close together as to overlap; for in this latter case the greenish-blue image of the left-hand spectrum, corresponding to the α index of refraction, occupies the same position as the image for yellow sodium light of the right-hand spectrum corresponding to γ would occupy in the case of caesium sulphate, the α refractive index for F-light being 1.5660 and the γ index for Na-light being 1.5662. The progression of the alteration of the amount of the double refraction is thus very striking, as the atomic weight (and atomic number) of the metal is varied.

Websky signal-slit is narrow at the centre to enable an accurate allocation to the vertical cross-wire of the telescope to be made, but wide at its top and bottom ends, in order to transmit ample light, and Fig. 66 shows four images of this signal produced by each prism, namely, one R in red C-hydrogen light and another B in greenish-blue F-hydrogen light belonging to each of the two spectra, in order to locate the two ends of each

The third illustration of the law of progression with atomic weight and sequence number is also an optical one, and is taken from the monoclinic series of double sulphates and selenates. It indicates the rotation, with increase of the atomic weight and number of the metal, of the ellipsoid which graphically represents the optical properties, about the unique axis of symmetry, which is likewise an axis of optical symmetry, of the crystal. In the potassium salt the ellipsoid occupies the position indicated by the ellipse drawn in continuous line in Fig. 67, the section of the ellipsoid by the symmetry plane; the outline of a tabular crystal parallel to the symmetry plane is also given, as well as the axes of the crystal and of the ellipsoid lying in that plane.

In the rubidium salt the ellipsoid has rotated over to the left, as indicated by the dotted ellipse, for a few degrees, the number of which varies slightly for the different groups of double salts; while in the caesium salt it has swung over much more still, to the place marked by the ellipse drawn in broken line. In both this and the last illustration it will be remarked that the optical change is greater between the rubidium and caesium salts than it is between the potassium and rubidium salts, the reason being that the optical properties are usually functions (of the atomic weight and number of the interchangeable elements) which are of an order higher than the first corresponding to simple proportionality.

These three ocular illustrations may serve to render this interesting law of progression, according to the atomic weight and atomic number of the interchangeable elements which give rise to the isomorphous series, clearer to the mind, by placing before it concrete instances of the operation of the law.

The generalisation itself may be very concisely expressed in the statement that :

The whole of the properties, morphological and physical, of the crystals of an isomorphous series of salts are functions of the atomic weights and atomic numbers of the interchangeable chemical elements of the same family group which give rise to the series.

The fact that this law extends to the structural dimensions, equally with all other morphological properties, as stated under (3)

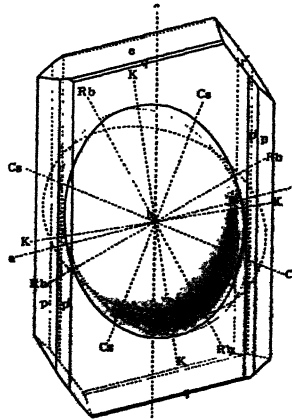

FIG. 67.—Diagram illustrating Progressive Rotation of Optical Ellipsoid in Monoclinic Isomorphous Series.

at the beginning of this chapter, is of especial interest. For it has actually been found possible to determine the relations of the dimensions of the unit parallelepipeda of the space-lattices of the various salts, that is, the separation of the molecular or polymolecular representative points of the space-lattice in the directions of the three crystal axes, for the various salts of the isomorphous series. This is achieved by combining in suitable formulæ the volume of the unit cell of the space-lattice with the relative lengths of the three crystal axes, a , b , c .

The axial ratios $a : b : c$ are calculated from the measurements of the crystal angles, as explained in Chapter VII, page 60, and the volume is the physical constant long known as "molecular volume," but now for the first time understood as regards its meaning in the case of solid substances. It is the quotient of the chemical constant molecular weight (the sum of the atomic weights, taking into account the number of atoms of each element present) by the specific gravity of the substance, here the solid crystal. Very great care has been taken to obtain absolutely accurate determinations of the specific gravities of the salts, as much depends on this now very valuable physical constant, and all the values obtained were reduced to the constant reference temperature of 20° , as the density notoriously alters rapidly with change of temperature. This reduction to constant temperature was rendered very accurately possible by the fact that the author had made very careful determinations of the thermal expansion of the rhombic alkali sulphates, with the aid of an original interference dilatometer, shown in Fig. 163 on page 236. This instrument affords measurements of small movements or distances with the most extreme refinement yet attained, namely, to the eight-millionth part of an inch, the half wave-length of the monochromatic light employed being the infallible grosser unit of the scale.

We have thus arrived at morphological constants of very considerable importance, which are best termed "*Molecular Distance Ratios*," as they express the relative distances apart in the three directions of space of the centres of gravity or other representative points of contiguous chemical molecules, or small groups of molecules. They have also been termed "*Topic Axial Ratios*" (from $\tau\omicron\pi\omicron\varsigma$, "space"). They are dependent on three experimental determinations, atomic weight, specific gravity, and crystal angles, all of which have now been brought to the highest pitch of refinement and accuracy; hence the molecular distance or topic axial ratios are particularly trustworthy constants. If it were only known how much is matter and how much is space in the molecular or polymolecular parallelepipedal cell, we should actually have in these constants a relative measure of the sizes of the molecules.

They do give us, however, the relative directional dimensions of the molecular, or polymolecular unit parallelepipedal cells of the space-lattices of the various members of the isomorphous series, just as the molecular volumes give us the relative volumes of these cells. For in an isomorphous series we are absolutely sure that the plan on which the space-lattice is constructed, its style of architecture, is identical for all the members of the isomorphous series. Also, if the grosser structural unit be a group of two to four molecules, the number of molecules in the group is the same throughout the series. Hence, the molecular distance, or topic axial ratios, are in these cases absolutely valid and strictly comparable. The ratios are generally expressed by the Greek letters $\chi : \psi : \omega$.

On comparing the molecular distance or topic axial ratios for a potassium, a rubidium, and a caesium salt of any of the series of sulphates, selenates, permanganates, perchlorates, double sulphates or double selenates investigated, we invariably find that the values of χ , ψ , and ω for the rubidium salt (rubidium having the intermediate atomic weight and atomic number) lie between the analogous sets of three values for the potassium and caesium salts respectively, in complete accordance with the law.

For the generalisation to apply absolutely it is essential that the interchangeable elements shall belong strictly to the same family group of the periodic classification of Mendeléeff. Potassium, rubidium, and caesium fulfil this condition absolutely, both as regards vertical group (I) and oddness or evenness of the horizontal series (4, 6, 8), and so the law of progression of the crystal properties with the atomic weight and atomic number of the interchangeable elements applies rigidly to their salts. Now there are two bases, the metal thallium and the complex radicle group ammonium NH_4 , which are not thus related to the group of three alkali metals just mentioned, but which are yet capable of replacing those metals isomorphously in their crystals without more change of angle or of structural constants than is provoked by the replacement of potassium by caesium; and often indeed the amount of change has been singularly like the lesser amount observed when rubidium has been interchanged for potassium.

So true is this as regards the molecular volumes and topic axial ratios that these constants are almost identical for analogous rubidium and ammonium salts; in other words, these salts are almost perfectly isostructural. This is further confirmed by the fact that they crystallise together in all proportions as mixed crystals, and readily form overgrowths on each other, a property only displayed when the structural dimensions are very close. The analogous potassium and caesium salts, which differ most in molecular volume and topic axial ratios, do not crystallise together

at all, and the potassium and rubidium salts, or the rubidium and caesium salts, only do so imperfectly, their structural dimensions, while not extremely wide apart, being still considerably different.

As regards the interfacial crystal angles, the directions of the changes occurring when potassium is replaced by ammonium or thallium are irregular, being sometimes the same as when rubidium or caesium is introduced, and sometimes contrariwise, and in the case of thallium there are also striking optical differences, the thallium salts being exceptionally highly refractive. Still, morphologically the ammonium and thallium salts may legitimately be included in the same isomorphous series with the salts of potassium, rubidium, and caesium, and a somewhat wider interpretation has to be given to the term "isomorphism" in order to admit these cases. To distinguish the inner group formed by the family analogues, potassium, rubidium, and caesium, that is, the more exclusive group obeying the law of progression according to the atomic weight and atomic number, the term "eutropic" is employed.

Thus the "isomorphous series" of rhombic sulphates and selenates, and that of the permanganates and perchlorates and the monoclinic series of double sulphates and double selenates, comprise the potassium, rubidium, caesium, thallium and ammonium salts and double salts of sulphuric and selenic acids and of permanganic and perchloric acids, while the inner more exclusive "eutropic series," following the law absolutely, comprises in each case only the salts containing the family analogues, potassium, rubidium, and caesium.

The logical reason for, and explanation of, this interesting law of progression of the crystal properties with the atomic weight and atomic number, is afforded by the far-reaching generalisation of Moseley, referred to on page 90. For, as the complexity of the chemical atom progresses regularly with the atomic sequence number in the periodic table—the positive electrical charge on the nucleus, and the actual number of the negative satellite electrons, being actually indicated by and identical with the atomic number—so do the properties of the crystals of the isomorphous series of substances formed by the interchange of these atoms of progressive complexity likewise alter progressively and definitely. Thus the law of progressive crystal change is but a natural consequence of the law of Moseley, and what has hitherto been but a remarkable and inexplicable fact is now found to be really only the natural consequence of the operation of a fundamental law controlling the complexity and evolution of the atoms of the chemical elements themselves.

In this beautiful manner has the controversy between the schools

of Haiÿ and Mitscherlich now been settled, the interesting law described in this chapter having definitely laid down the true nature and limitations of isomorphism, while at the same time absolutely proving as a law of nature the constancy and specific character of the crystal angles of every definitely chemically constituted substance, not crystallising in the cubic system of perfect symmetry and fixed angles.

CHAPTER XII

THE REVELATION OF CRYSTAL STRUCTURE BY X-RAYS. THE LAW OF ATOMIC DIAMETERS

SINCE the first edition of this book was published in the year 1911 the structure of a crystal which has been developed in the foregoing pages—as being that of one of the fourteen space-lattices of Bravais as regards the grosser (molecular or polymolecular) structure, and of one of the 230 point-systems as regards the ultimate detailed (atomic) structure—has received absolute confirmation of a most remarkable and unexpected character. For it was discovered in the year 1912, by Dr. M. Laue in Munich, that the planes of atoms of the space-lattice structure were capable of reflecting X-rays, by virtue of the fact that the minute order of size of atoms is very similar to the excessively short wave-length of these radiations derived from a Crookes' tube. It was known that the size of a molecule of hydrogen consisting of two atoms, for instance, was about 1.64×10^{-8} centimetres, and that an average wave-length of X-radiation was about 0.5×10^{-8} centimetre (that from a palladium anticathode, for example, has since been shown to be 0.584×10^{-8} centimetre).

The scientific coterie at Munich in the year 1912 was a remarkable one. It included Prof. von Röntgen the discoverer of X-rays, Prof. von Groth the doyen of crystallographers, Prof. Sommerfeld famous for X-ray research in connection with atomic structure, Prof. Ewald the authority on gratings for long electromagnetic waves, and Dr. (now Prof. von) Laue a keen worker on interference and diffraction in optics. Assembled in common room one evening, a discussion arose as to whether the extremely short X-rays would be likely to be capable of reflection by the planes of atoms within a crystal. Dr. Laue's assistant, W. Friedrich, who was present, offered to try the experiment, and with the assistance of a colleague, P. Knipping, did so next day. The experiment was carried out on a crystal of zinc blende (zinc sulphide, ZnS), and Dr. Laue having been called in on its repetition, the three observers were delighted to find that it was brilliantly successful. For on receiving the X-rays normally on the crystal plate (a natural tabular crystal) and permitting them to traverse the crystal, and then receiving the transmitted rays on a photographic plate placed behind the crystal and developing the plate, each plane of atoms affected

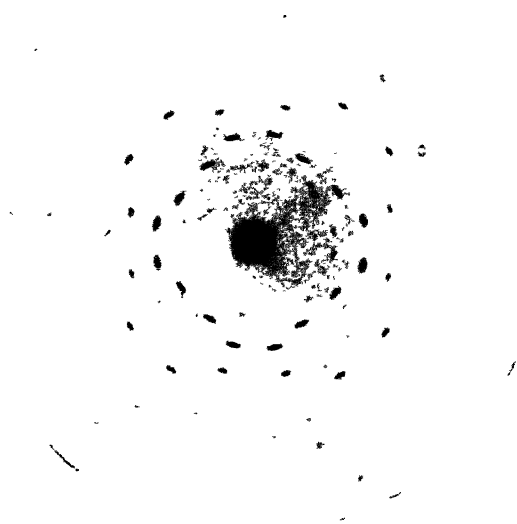

FIG. 68.—Original Laue X-Radiogram of Zinc Blende

was found to have recorded itself by an elliptical dark spot where the rays reflected or diffracted by that plane had impinged on the sensitive plate, the series of these spots forming a symmetrical pattern around the intense central spot caused by undiffracted direct rays. That is, the spots were observed to be arranged in a geometrical pattern having the symmetry of the cubic system, to which the crystals of zinc blende belong. Every plane of atomic points in the space-lattice, parallel to every possible crystal face, met by the incident beam of X-rays, had responded and declared itself by its reflection or diffraction spot, and a careful analysis of this remarkable radiogram confirmed absolutely the structure assigned to crystals of zinc blende by the crystallographer, as derived from the measurement of its external interfacial angles and the determination of its optical properties, with one reservation. This exception was, that only the holohedral or full cubic symmetry (class 32) was indicated, whereas zinc blende really belongs to the hexakis tetrahedral class (31) of the cubic system.

This remarkable reaction of X-rays towards crystals was not surface reflection from the crystal faces, but reflection from, or diffraction by, the various planes of atoms well inside the crystal. In accordance with the law of rational indices (the reason for which has been shown in Chapter X, page 95, to be afforded by the space-lattice structure), all such planes of atoms, corresponding to the planes of "points" of the space-lattice, were possible crystal faces, and some of them were developed on the crystal employed; the largest of the cube faces was the one perpendicular to which the incident X-rays impinged on the crystal. The greater part of the rays, indeed, had passed through the crystal directly to the sensitive plate, on which they had produced the strongest and circular central spot. The successive parallel internal planes of atoms had acted towards the X-rays in like manner to that in which a diffraction grating acts towards light waves; but instead of a one-dimensional grating of engraved parallel lines acting on light waves, the successive planes of atoms parallel to any plane of points of the space-lattice acted as a 3-dimensional grating towards the X-rays (for the particles are in general differently spaced in the three directions of space, although the three dimensions become, of course, equal in the case of the simple cube).

During a visit to Munich in August, 1912, the original pioneer photograph with zinc blende was shown to the author, and Dr. Laue subsequently sent a lantern slide prepared from it for a lecture delivered by the author at the Royal Institution in March, 1913, together with transparencies of many other radiograms taken shortly after the first and of pictures of the apparatus used in the experiments. This historic first radiogram and the view of the

first apparatus, are reproduced in Fig. 68 on Plate XVI and in Fig. 69.

What was happening in these experiments of Laue and his associates was, that the X-rays of very short wave-length, falling on the grating composed of the atoms arranged like the points in a plane of the space-lattice (any three points of the lattice determining a plane), were diffracted in identical wave-trains from each of these atoms, the whole plane acting as a unit of the grating, and the parallel succession of such whole planes acting as the grating itself. Laue obtained a mathematical expression for the intensity at all points due to the diffraction of waves of known wave-length

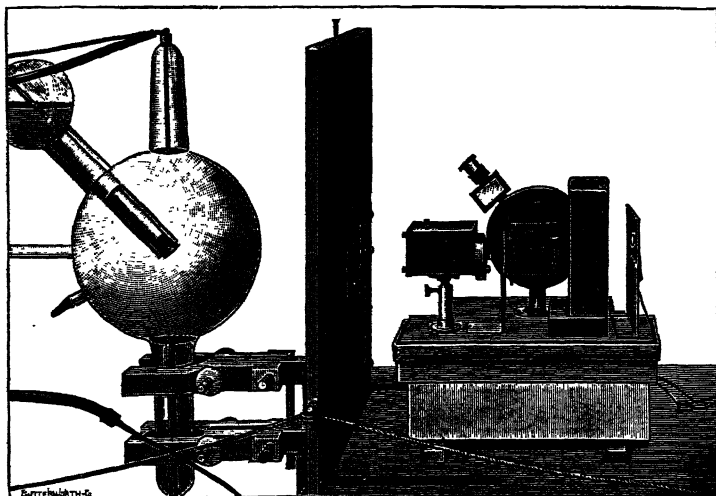

FIG. 69.—Laue's original Apparatus for producing X-Radiograms of Crystals.

incident on a set of particles arranged on a space-lattice, and a study of this expression showed that the spots on the radiogram were situated, around the central very intense spot afforded by the incident beam, so as to agree precisely with the supposition that they were due to diffraction. Each different kind of plane gave a separate diffraction spot. The effect (referring to any one spot) was not due to one plane only, however, the diffracted energy from one plane not being sufficient to affect the sensitive plate, but to the combined or reinforced action of the bundle (very large number) of successive planes parallel to it.

Prof. Sir W. H. Bragg and his son, Mr. (now Prof.) W. L. Bragg, subsequently gave a simpler mode of regarding the case, which is illustrated in Fig. 70.

When a ray PP passes over the atoms in the plane AA , each emits a diffracted ray which spreads spherically, and is represented

by the circles, all of which touch a "reflected" wave $P'P'$, that is, all the diffracted waves combine to form a wave-front which obeys the laws of reflection from a plane.

Now it has been made clear in this book that in the crystal space-lattice there are many ways of choosing such planes of atomic points, but only a very few of these planes will be thickly bestrewn with points; those corresponding to cleavage planes and the primary faces will be the most densely studded, and the more complex the planes and rarer the faces corresponding to them (the higher the facial indices) the more thinly will they be packed with points. Therefore, when a wave of X-rays passes over the crystal its scattered energy is concentrated into definite beams, which may be regarded as feeble reflections of the rays on the planes of

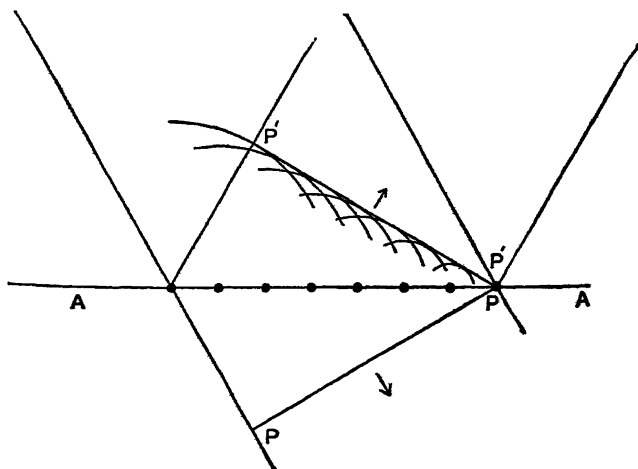

FIG. 70.

atoms (corresponding to possible crystal faces) in the interior of the crystal, and it is these definite beams which produce the spots of the radiogram. It cannot be made too clear that it is not surface reflection of X-rays on an exterior crystal face which is concerned. No such surface reflection of X-rays is possible to the extent observed, for the first few layers combined are incapable of diffracting any appreciable proportion of the rays; the latter have to pass through millions of layers before the X-rays are appreciably absorbed. Reflection takes place on all the layers, but when the latter become too deep inside the crystal the absorption by the outer layers renders the reflection negligible as regards affecting a photographic plate. While, in the case of light waves, the amplitude and wavelength are so large compared with the size of the atom that the crystal medium is then practically continuous, in the case of X-rays

the amplitude and wave-length are so short that a crystal is to these waves a regularly arranged space-lattice of widely separated particles (forming the nodes of the lattice), and each particle is then only capable of diffracting a very minute proportion of the energy of the rays. But the combined effect of a very large number of successive parallel planes is sufficient to afford diffracted rays of intensity adequate to produce the observed effect on the photographic plate.

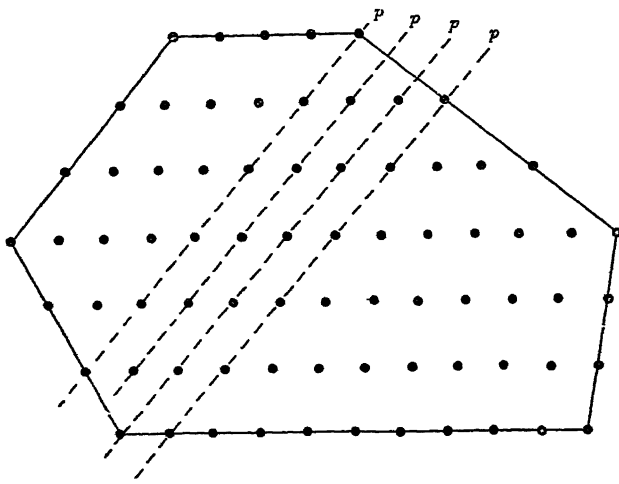

FIG. 71.

Sir William Bragg next carried the subject a very considerable stage further. Instead of sending the X-rays through the crystal and obtaining a diffraction pattern on a photographic plate placed on the other side (at the back) of the crystal, he used the crystal directly as a reflector for X-rays, obtaining a reflection of the X-rays (proceeding in a fine pencil from the slit of a leaden collimator, lead being practically impervious to X-rays) from the planes of atoms within the crystal, parallel to a well-developed crystal face adjusted to the correct glancing angle on the spectrometer-goniometer; and, instead of making the reflection record itself on a sensitive plate, he received it in an ionisation chamber of tubular form acting instead of the telescope of the spectrometer. Suppose, for instance, the upper left face in Fig. 71 has been adjusted, and *pppp* are four planes of atoms parallel to it. Suppose, further, that in Fig. 72 we have these same four successive parallel planes of atoms, separated by the equal distances d (the spacing). If then, A, A_1, A_2, A_3 be a train of advancing waves of X-rays of wave-length λ meeting the first plane at B , and BC be their reflection

tion, the other rays which will be reflected in common along BC from the other three lower planes p will be $A'B'$, $A''B''$, $A'''B'''$. Now if we draw BN perpendicular to $A'B'$ produced and BD perpendicular to the planes p to meet this line $A'B'$ also at D, it will be clear that the difference between the path $A'B'C$ and ABC is equal to ND, and that the path $A''B''C$ is still greater by the same quantity, and so on. Now if ND be equal to the wave-length λ or to any whole multiple of it, all the wave-trains reflected by the planes p are in the same phase, and the amplitudes are added to each other. If the distance ND be different, even but slightly, from the wave-length, the numerous reflections of all kinds of phase simply destroy each other. Hence, if a "monochromatic" wave-train of X-rays be used, it is only when the glancing angle θ has certain well-defined values that reflection is observed to occur.

Now $ND=2d \sin \theta$, so that the definite values in question, θ_1 , θ_2 , θ_3 , etc., will be:—

$$\begin{aligned}\lambda &= 2d \sin \theta_1, \\ 2\lambda &= 2d \sin \theta_2, \\ 3\lambda &= 2d \sin \theta_3, \text{ etc.}\end{aligned}$$

The angle θ_1 is that of the reflection of the first order, that at θ_2 is of the second order, and that at θ_3 of the third order, and so on. Hence, if the crystal be rotated on the goniometer-spectrometer we come to three particular successive positions, when the angle becomes θ_1 , θ_2 , θ_3 , etc., at which reflection of the X-rays impinging on the crystal is observable (by its ionising effect). Knowing the wave-length, we can at once calculate from the

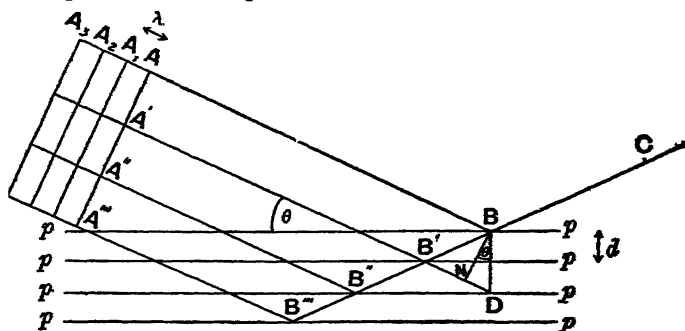

FIG. 72.

formula the spacing d of the planes $pppp$ from each other. Another crystal face (the planes of atoms parallel to it) having a different relation to the symmetry of the crystal (that is, not belonging to the same "form"), would afford a different value for d , the angles θ_1 , θ_2 , θ_3 , etc., being different.

Sir William Bragg's X-ray spectrometer, as in actual use at University College, London, is shown in Fig. 73. It consists essentially of a goniometer-spectrometer with the ordinary telescope replaced by a tubular ionisation chamber, a tube somewhat wider than that of a telescope, filled with sulphur dioxide, SO_2 , or methyl bromide, CH_3Br , both of which gases are particularly readily ionisable by X-rays; this chamber is connected with a Wilson tilted gold-leaf electroscope, to indicate the amount of the ionisation.

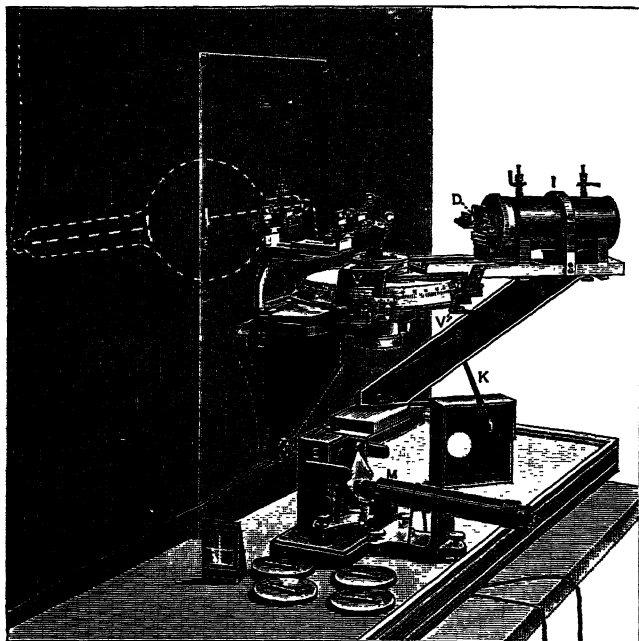

FIG. 73.—The X-Ray Spectrometer.

The deflection of the gold leaf is read off by a microscope, and matters are so arranged that a strong reflection of X-rays from the crystal causes the leaf to move to the extent of twenty divisions of the scale per second. The X-rays are admitted through a slit in a leaden screen, and the X-ray bulb is sheltered behind a leaden box (lead being particularly impervious to X-rays).

The principle of the use of an ionisation chamber is as follows: The ionisation of gases by X-rays, which is one of the most interesting phenomena experimentally found to occur in connection with these wonderful radiations, is effected solely by means of the β -rays, or negative electrons, which spring up in the path of the X-rays during their passage through the gas, and to which their

energy is transferred. These β -rays or free electrons are generally derived from the metallic walls of the tubular chamber, which in these experiments contains the gas, unless the latter is very dense. Usually the gas employed by Sir William Bragg is sulphur dioxide, SO_2 , but sometimes, with the more penetrating X-rays, methyl bromide, CH_3Br , is used. What occurs is that the electrons (β -rays) immediately form "ions," that is, electrically charged molecules, in the gas; these ions, however, are not the same as those met with in electrolytic dissociation. Each electron attaches to itself a number of molecules of the gas, and so forms a gas ion. If the velocity of the electron be very great, it may produce a large number of positive and negative gas ions. But these ions do share one property in common with those produced in electrolytic dissociation, namely, they impart a certain degree of electrical conductivity to the gas, so that if the latter be raised in its chamber to a fairly high potential, by means of a storage battery, for instance, and it be connected with an electroscope, a current or discharge passes and the electroscope is affected. The conductivity only lasts, however, until the positive and negative ions have apparently recombined and again formed neutral molecules; the process is really that of the combination of the electrons in the positive gas ions with those in the negative gas ions. Hence, the current is only brief, more like a discharge, but it lasts long enough to enable one to measure it. The metallic chamber containing the gas, usually a wide tube like a spectroscopy collimator or telescope, is itself insulated and raised to a high potential by means of a storage battery, and it has an electrode mounted within it axially and nearer one end, and so placed that it is not in the way of the stream of X-rays entering the tube, and it is to this electrode that the Wilson tilted gold-leaf electroscope is attached by means of a wire.

A few typical cases of the use made in this manner of X-rays to elucidate crystal structure may now be given.

One of the most important substances studied is rock-salt, sodium chloride, NaCl . The Braggs had already shown that the planes of atoms parallel to a cube face of a crystal of rock-salt are spaced at intervals of 2.81×10^{-8} cm., using the palladium anticathode affording the monochromatic X-radiation of the wave-length 0.584×10^{-8} cm. For these planes of atoms afford strong reflections of the palladium rays at the angles $5^\circ.9$ (first order), $11^\circ.85$ (second order), and $18^\circ.15$ (third order); and inserting these values in the formula $n\lambda = 2d \sin \theta$ (in which in the three cases $n=1, 2,$ and 3 respectively), we obtain the value for $d=2.81 \times 10^{-8}$ cm. Normally the relative intensities of the first five orders of reflection are as $100 : 20 : 7 : 3 : 1$, and this order is well conformed to by the reflections from the rock-salt cube planes (100), and also from the planes of the rhombic

dodecahedron (110) of this substance. When successive planes of atoms differ in composition or distances of separation, however, the usual intensities of the three orders are upset, and in a manner which is very instructive. Now the reflections from the octahedral planes of atoms (111) of rock-salt exhibit just such an altered intensity relation of the orders, the first order reflection being weak, the second order strong, and the third order very feeble, while there is quite a good fourth order reflection also obtained. The reason is that the octahedral planes are composed alternately of sodium and of chlorine atoms. The structure of rock-salt is that of the simple cube lattice No. 1, when both kinds of atoms are considered irrespectively; but if each kind of atom—sodium or chlorine—be considered, it is that of two interpenetrating face-centred cubic space-lattices No. 3. The face-centred cube is shown in Fig. 74, and the structure of rock-salt in Fig. 75.

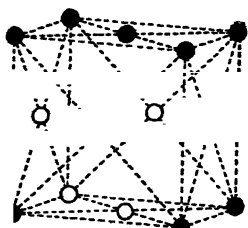

FIG. 74.—The Face-Centred Cube.

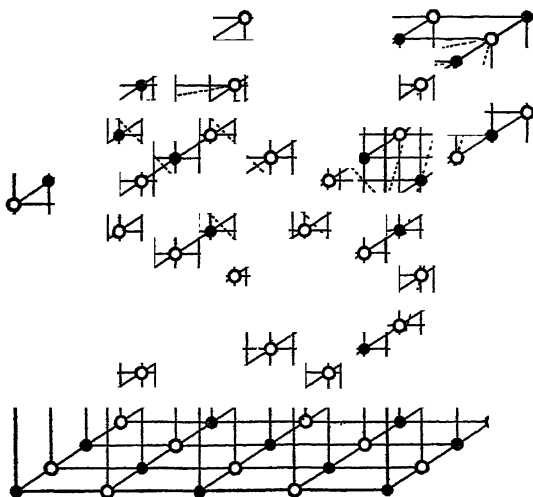

FIG. 75.—The Structure of Rock Salt.

Now the intensity of reflection from an atom is proportional to its mass,¹ which may be represented by its atomic weight. The atomic weight of sodium being 23 and that of chlorine 35.5,

¹ We may state this otherwise thus: The amplitude of the waves reflected by each net-plane is nearly proportional to the total mass of the atoms lying in that net-plane.

alternate octahedral planes reflect in this proportion, and it is only the alternate identically similar planes that correspond to d in the equation and give the normal second order reflection. The first order reflection is almost destroyed, as well as all odd order reflections, as the waves from the chlorine planes are not quite in phase with those from the sodium planes.

If we consider now the corresponding chloride of potassium, sylvine, KCl, the atomic weights of potassium (39) and chlorine (35.5) are so nearly the same that the atoms reflect almost identically, and the crystal behaves as if the structure were that of the simple-cube lattice and composed of identical atoms. Hence, potassium chloride gives the reflections from the (100), (110), and (111) faces to be expected from a simple cubic lattice. For the corresponding reflection maxima from the three faces, (100) (cube), (110) (rhombic dodecahedron), and (111) (octahedron), occur at the angles, $5^{\circ}22'$, $7^{\circ}30'$, and $9^{\circ}05'$, the sines of which, 0.0910, 0.1272, and 0.1570, are in the ratio $1 : \sqrt{2} : \sqrt{3}$, which is the characteristic of the cubic space-lattice. Thus the cube and rhombic dodecahedron planes of atoms of both sodium and potassium chlorides afford normal reflections of the usual relative intensities. But while the octahedral planes of sylvine also afford reflections of X-rays which show normal relations, corresponding to the simple cubic lattice arrangement, those of rock-salt give a stronger second order reflection than the first order one, which is feeble, and quite a good fourth order reflection, while the third order reflection is scarcely perceptible. In the case of rock-salt, it is the side of the small cube which has the length 2.81×10^{-8} cm. The various sections of Fig. 75 corresponding to (100) and (110) are identical in each case, respectively, consisting of equal numbers of metal and chlorine atoms, represented respectively by the dots and rings. The sections parallel (111), however, will be seen to be alternately composed of layers of chlorine atoms and layers of metallic atoms, which in the case of sylvine behave similarly, as their atomic weights are nearly the same; in the case of rock-salt, on the other hand, the result of the interference of rays coming from layers 1, 3, 5, 7, etc., will be different from that of the waves coming from the alternating layers, 2, 4, 6, 8, etc. The latter series will have a phase opposite to that of the former series, but as their amplitudes are different they will not completely counterbalance each other. The spacing of the layers of atoms parallel to the cube (100) faces of rock-salt has been shown to be 2.81×10^{-8} cm.; that of the analogous (100) layers of sylvine is 3.15×10^{-8} cm.

To render this important point concerning the octahedral (111) planes of sodium and potassium chlorides quite clear, as it involves a principle of general application, let us consider the effect of a

set of parallel atom-bearing planes uniformly spaced but alternately of unequal densities a and b . The accompanying Fig. 76 shows the effect of giving b various values, beginning with a and ending in zero. The relative intensities and glancing angles (more correctly their sines) of the different orders of reflection are shown in each case.

It is assumed that when the planes are all alike and equally spaced the intensities in the different orders are as the inverse squares of the orders, because some assumption is necessary for the

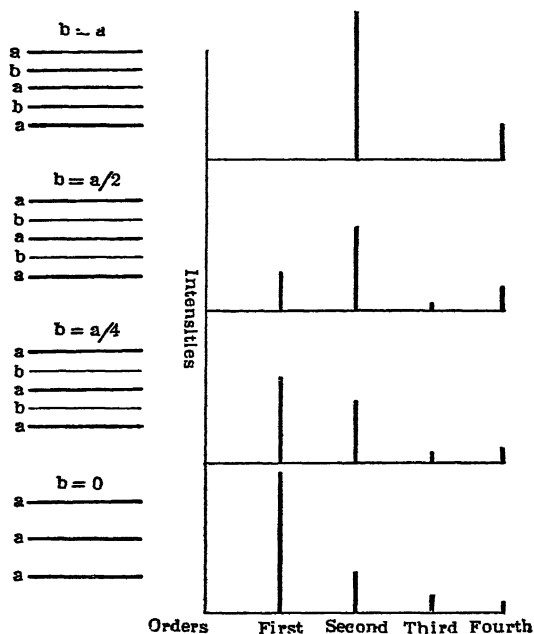

Fig. 76.—Relation between Densities of alternate Planes of Atoms and Intensities of Reflection Orders.

purposes of illustration, and this particular assumption has been found to be nearly correct in several actual cases.

Now the case of potassium chloride, KCl, is that shown at the top of Fig. 76, when $b=a$, and two of the orders of spectra are represented by the thick lines, as regards their glancing angles by their positions along the horizontal base-line, and as regards their relative intensities, which are normal, by the heights of the thick lines themselves. The successive planes all behave alike, the atoms of potassium and chlorine composing them being of approximately equal atomic weight, 39 and $35\frac{1}{2}$, and therefore of equal reflecting power.

If, however, planes at double this spacing of the KCl (111) planes

were present, alone, we should have the effect shown at the foot of Fig. 76, where $b=0$, that is, the b -planes would have now disappeared. In this case we should have a normal series of spectrum orders, at approximately only half the previous angles (more correctly, at angles the sines of which are half as great, for in $\lambda=2d \sin \theta$ if d be doubled $\sin \theta$ must be halved, as λ remains the same, a single wave-length corresponding to a first order spectrum). Hence, all four orders are shown in this bottom case, the first order

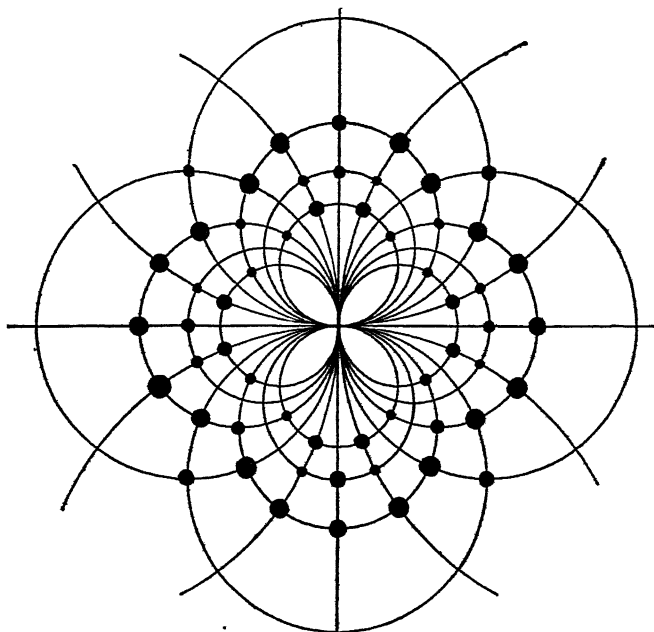

FIG. 77.—X-Radiogram of Rock Salt.

appearing at half the distance along the line compared with the first order spectrum of the top case, and a third order appearing midway between the first and second orders of the top case.

When, however, the b -planes are present, although not so strongly capable of reflecting on account of lower atomic weight of the atoms, we have the cases represented by the second and third types in the Fig. 76, where $b=a/2$ and $b=a/4$. The second case most closely resembles that of rock-salt NaCl, where we have atoms of atomic weights 23 and $35\frac{1}{2}$. If the intermediate planes b were of equal reflecting power with the a planes, the first order of the bottom case would disappear altogether, this case becoming really

identical with the top case. For we should have two sets of reflections, from a and b planes respectively, the phases of which would be exactly opposite and the amplitudes equal, extinction being therefore the natural result; in other words, no reflection at all would be perceptible at this angle. But the case of rock-salt being an intermediate one as regards the amplitudes of the two opposite-phase reflections, some of the reflection of the greater amplitude and therefore greater intensity would persist, unextinguished, and we should have the second case presented, namely,

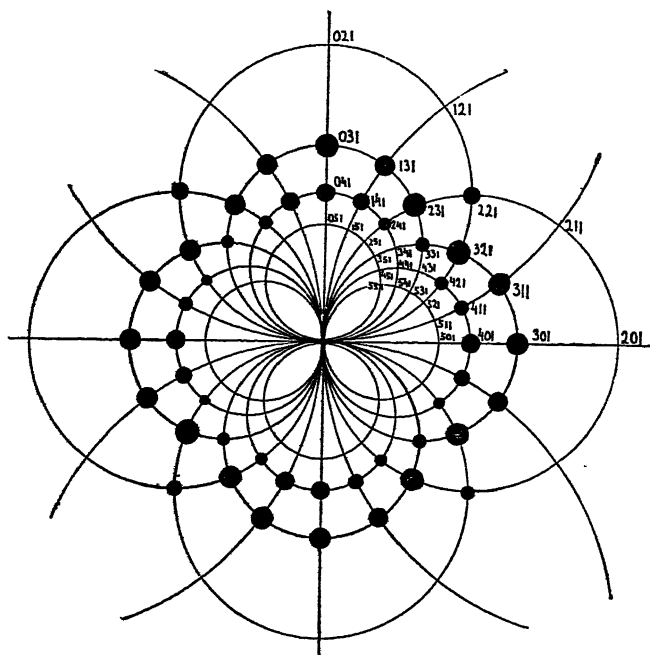

FIG. 78.—X-Radiogram of Sylvine.

a more or less feeble first order reflection, a strong second order one, a very faint third order reflection, and a more appreciable fourth order one.

The Laue radiograms (diagrammatically constructed on the same principle as the stereographic projection) for rock-salt and sylvine are given in Figs. 77 and 78. The spots in Fig. 78 are perfectly regular, corresponding to a simple-cube lattice. Those in Fig. 77 lie on the same circles, but some are missing, and the intensities, represented by the sizes of the spots, are different, corresponding to the face-centred-cube lattice. Each spot lies on two circles, which are the stereographic projection of ellipses, the sections of

a cone having the zone axis as its axis and the direct and reflected rays as two generators; the diagram thus obtained is only slightly different from the actual photograph, on which the ellipses are readily recognisable, and it is much easier to draw circles than ellipses.

The intensity of the Laue spot depends on the number of atoms in the plane affording it; the greater the reticular density the more intense the spot. As reticular density goes with importance of crystal face and simplicity of facial indices, the most important facial planes, the primary faces, reflect the intensest spots.

In a similar manner, from the determinations by the Bragg method

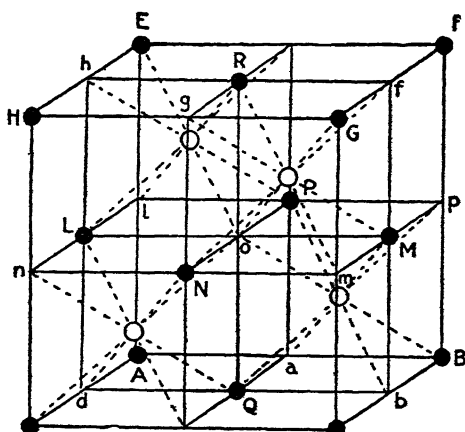

FIG. 79.—The Structure of Zinc Blende.

of the glancing angles of reflection of the X-rays from the planes of atoms parallel to the principal faces of the crystals, and from the study of the relative intensities of the spectra of the first, second, third, fourth, and fifth orders, the structure of many other substances has been determined. Thus in the case of zinc blende, zinc sulphide, ZnS —the substance first studied by Laue and a radiogram of which is given in Fig. 68, Plate XVI—which also belongs to the cubic system, the zinc atoms are found to be arranged at the nodes of the face-centred-cube lattice, while the sulphur atoms are so distributed as to occupy the centres of four only (alternate ones) of the eight smaller cubes into which the face-centred-cube may be considered to be divided. This will be rendered clear by Fig. 79, in which corners and face-centres occupied by the zinc atoms are indicated by capital letters, the other nodes indicated by small letters and also the centres of alternate cubelets being unoccupied.

Moreover, a remarkable fact was discovered about the diamond ; for it was shown that this most exquisite of all crystallised structures, composed of the element carbon in its most highly organised form, is precisely like zinc blende, both zinc and sulphur atoms, however, being of course replaced by carbon atoms. The second order X-ray reflection from the octahedron faces (111) of the diamond is completely extinguished ; for the alternating layers in this case are obviously composed of identically similar atoms, and the amplitudes of both oppositely directed secondary vibrations are, therefore, equal. In the case of zinc blende the (111) planes are alternately composed of zinc and sulphur, and are such that the distance separating the zinc atoms is four times that separating zinc and sulphur atoms. As the atomic weight of zinc is 65, just double that of sulphur, 32, the first order reflections from the sulphur

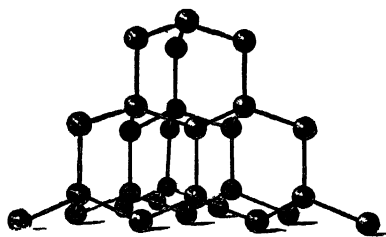

FIG. 80.—Model illustrating Structure of Diamond.

planes reinforce slightly those from the zinc planes ; but in the case of the second order reflections the waves from the sulphur planes are not in phase with those from the zinc planes, and only a weak reflection due to difference of atomic weight is obtained. This reflection would disappear altogether if the atomic weights were equal,

and this is actually the case with the diamond, the carbon atoms occupying precisely the positions of both zinc and sulphur atoms in zinc blende. The carbon atoms are arranged in two face-centred-cube lattices, the atomic points of one occupying the corners and face-centres of the main large cube, while those of the other are situated at the centres of alternate small cubes of the eight forming the large cube. Fig. 80 represents a model of the diamond in accordance with this structure, as standing on a (111) base.

The structure thus revealed agrees most remarkably with the chemical properties of carbon, and with the stereometric suppositions of Van t'Hoff and Le Bel, as regards the directions in space of the four valency bonds. For the balls representing the carbon atoms and points of the space-lattice obviously build up a tetrahedron, each atom having four others around it at equal distances. The sphere of influence of each atom is a regular tetrahedron, so modified by the rhombic dodecahedron that each tetrahedral face has become a regular hexagon. This deviates considerably from a true sphere, and the assemblage is not a closely packed one, but one loosely packed, a fact which does not agree with the suppositions of Barlow and Pope in their valency volume theory. It also shows

that the diamond is holohedrally cubic, of class 32, and not hexakis tetrahedral of class 31, and in this respect it confirms the recent work of Van der Veen and others.

The proof that the two space-lattices of the diamond and zinc blende are of the face-centred-cube type is that in each case the ratio of the sines of the angles of reflection from the three primary

planes of atoms (100), (110), and (111) are as $1 : \sqrt{2} : \sqrt{\frac{3}{2}}$, which

is the ratio characteristic of that lattice. The ratio for the simple cube lattice has already been given as that exhibited by sylvine, and the only other possible cubic space-lattice, that of the centred cube, is

characterised by a different ratio of the sines, $1 : \frac{1}{\sqrt{2}} : \sqrt{3}$.

Zinc blende is not a holohedral cubic (class 32) mineral, but belongs to the hexakis tetrahedral class 31, to which the diamond was formerly incorrectly also supposed to belong. The Laue radiogram, however, does not reveal this fact concerning zinc blende. Indeed, Friedel has shown that unfortunately the Laue radiograms can only distinguish eleven of the 32 classes of crystals, the exact rule being that the Laue radiogram indicates the symmetry actually possessed by the crystal plus an additional symmetry element, a centre of symmetry. The Bragg X-ray spectrometric method, however, is not so limited, owing to the further evidence afforded by the relative intensities of the different orders of the X-ray spectra, and many "hemihedral" structures have been elucidated by its means.

In a manner similar to the above unravellings of the structures of the alkali chlorides, zinc blende, and diamond, many other crystallised substances have been successfully investigated by the two X-ray methods. They include fluorspar CaF_2 , iron pyrites FeS_2 , the spinels, cuprite Cu_2O , metallic copper, silver, gold, and lead, all of which are cubic and mostly show the face-centred-cube type of main space-lattice, the elementary metals mentioned showing this lattice purely and simply. Among trigonal minerals calcite, ruby, and quartz have been investigated, the latter proving to have the atomic points spirally arranged about the trigonal axis, and in either a right-handed or a left-handed manner as expected.

Indeed, three crystallised substances of outstanding interest, of hexagonal or trigonal symmetry, are among those which have been investigated by means of X-rays, namely, ice, calcite, and quartz, and they deserve more than cursory mention. Spacings and lattice-cell dimensions are given in Angström units (one A.U. = 10^{-8} cm.).

Ice.—The combined results of independent investigations by A. St. John, D. M. Dennison, and Sir William Bragg, indicate that ice possesses the structure shown in Fig. 81. It is that of four interpenetrating close-packed hexagonal lattices, with edges 4.52 Å.U. long and 7.34 Å.U. in height, the axial ratio being $a : c = 1 : 1.62$. Each oxygen atom is at the centre of gravity of 4 neigh-

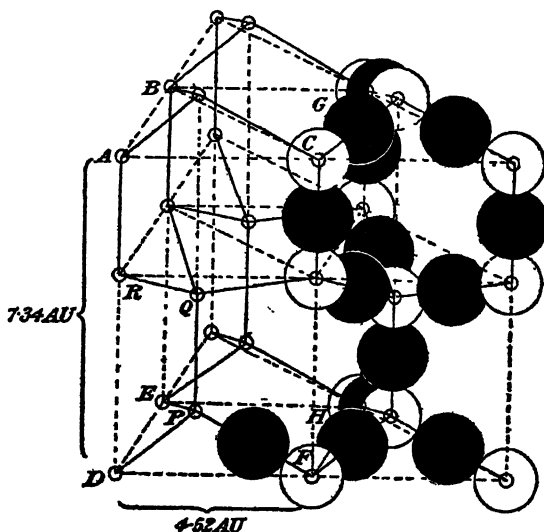

FIG. 81.—The Structure of Ice.

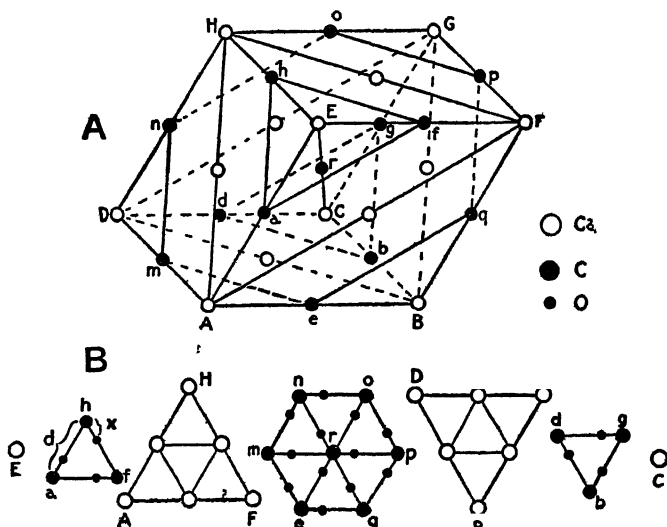

FIG. 82.—The Structure of Calcite.

bouring equidistant O atoms, from each of which it is separated by a hydrogen atom, there being twice as many H atoms round each O atom as there are O atoms round each H atom. The structure is an extremely open one, corresponding to the low density 0.9165. This explains why H_2O molecules, of liquid water, occupy less space, and the consequent expansion on freezing and the melting of ice by pressure. According to F. Rinne, ice crystallises in class 25 (apatite class, hexagonal bi-pyramidal) of the hexagonal system.

Calcite has been very thoroughly studied by Sir William Bragg, and proved to have the expected rhombohedral structure corresponding to class 21 of the trigonal system. The unit rhomb is the elementary space-lattice cell (space-lattice No. 7), and the spacing of the cleavage

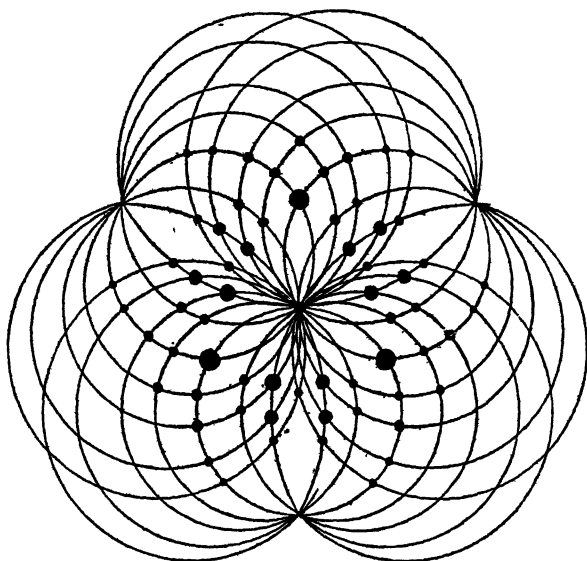

FIG. 83.—Laue X-Radiogram of Calcite.

(rhombofacial) planes (100) is 6.14 \AA.U. There are four molecules of $CaCO_3$ in the cell, and the structure is that shown in Fig. 82, a Laue radiogram being also shown in Fig. 83. The portion of the figure at A only shows the calcium and carbon atoms, but the disposition of the oxygen atoms also is shown at B, in the various evenly spaced layers parallel to the basal plane (111) and perpendicular to the vertical trigonal axis, these layers containing alternately Ca atoms and CO_3 groups. The axial ratio is $a : c = 1 : 0.8545$ and the density 2.71.

Quartz.—The structure of this very important mineral has proved more difficult of elucidation, but it has eventually been established

by Sir William Bragg that it is based on the hexagonal or trigonal 60° prism space-lattice No. 6. It is shown in Figs. 84 and 85. The hexagonal prism is consequently the chief form. The unit cell contains 3 molecules of SiO_2 , and there are three interpenetrating No. 6 space-lattices, one being derived from the other by a rotation of 60° about, and translation for $c/3$ along, the direction of the vertical trigonal axis. This axis consequently has the points

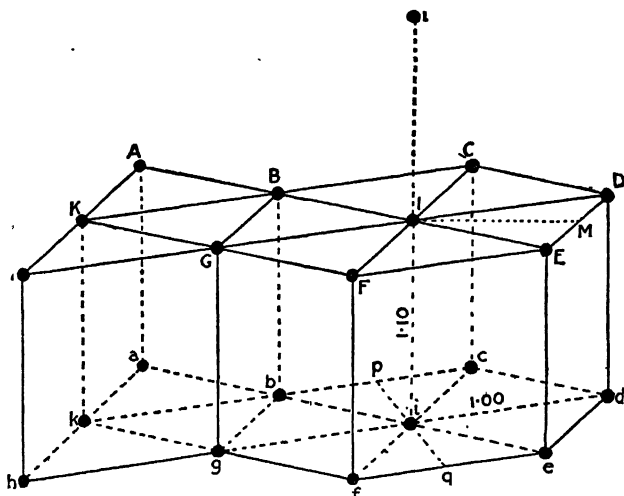

FIG. 84.—The Structure of Quartz.

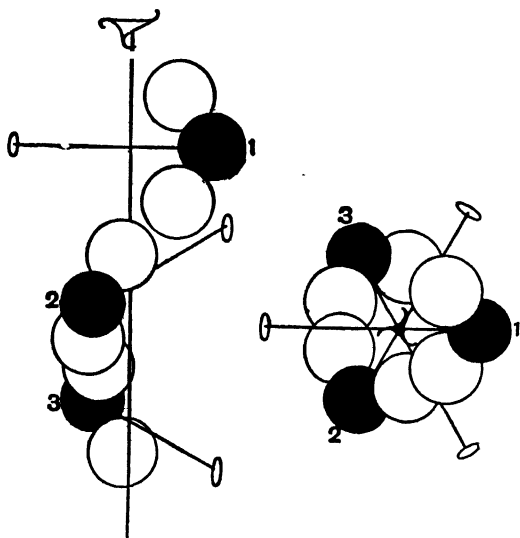

FIG. 85.—Spiral Arrangement of Atoms in Quartz.

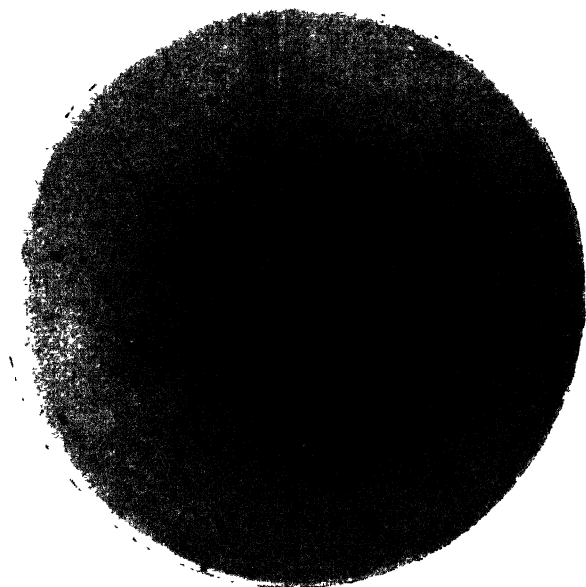

FIG. 86.—Beryl. Plate parallel (0001)

To face p. 126

arranged spirally around it, and the spiral may be either right- or left-handed, corresponding to the two varieties of quartz. In Fig. 85, the black discs represent Si atoms and the white ones O atoms. Three digonal axes intersect in the trigonal axis, and a Si atom lies in each digonal axis. This structure is obviously in accord with the characteristics of this especially interesting mineral. The axial ratio is 1 : 1.1000 and the density is 2.65.

The tetragonal minerals, zircon ZrSiO_4 , rutile and anatase TiO_2 , cassiterite SnO_2 , and thorite ThSiO_4 , have also been worked out.

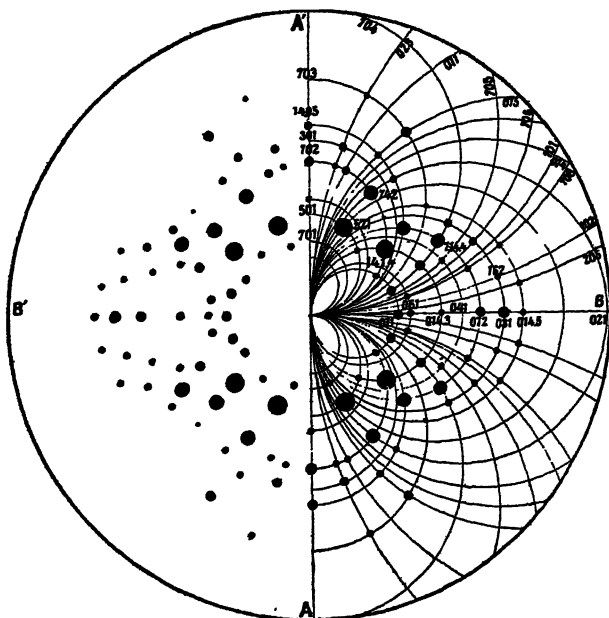

FIG. 89.—Anhydrite Parallel (001), diagrammatic.

In the rhombic system sulphur and the rhombic alkali sulphates have been investigated, and in the latter case with results (p. 129) fully confirmatory of the author's many years of work with those salts.

Besides these more fully investigated crystal structures, a considerable number of others have been investigated, as regards their Laue radiograms, by Jaeger and Haga and by Rinne. Reproductions of two of those obtained by Jaeger and Haga, namely of the hexagonal beryl and the rhombic topaz, are given in Fig. 86, Plate XVII, and Fig. 87, Plate XVIII. They are both taken with a plate parallel to the basal plane.

In the next two figures are given a pair of radiograms of the rhombic anhydrite, anhydrous calcium sulphate CaSO_4 , for a plate

parallel also to the basal plane, the first of which, Fig. 88, Plate XVIII, is a reproduction of the actual photograph, while the other, Fig. 89, is the same radiogram drawn diagrammatically from the principles enunciated by W. L. Bragg, according to which each spot is situated at the intersection of two circles. Fig. 89 also gives the indices of the faces from which the spots are diffracted. It incidentally also reveals more clearly the large number of spots shown by the radiogram, and indicates their relative intensities by their sizes. Some of the crystals experimented with by Jaeger exhibited many more spots derived from a very large number of faces; indeed, one case experimented with by Rinne showed as many as 400 faces.

The Laue method is thus capable in expert hands of affording a

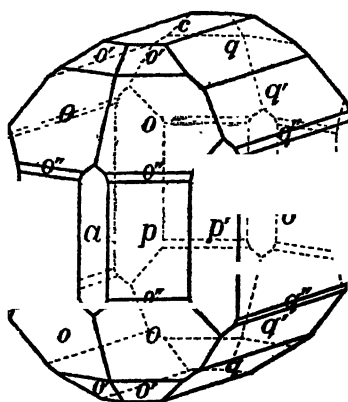

FIG. 90.—A Crystal of Potassium Sulphate.

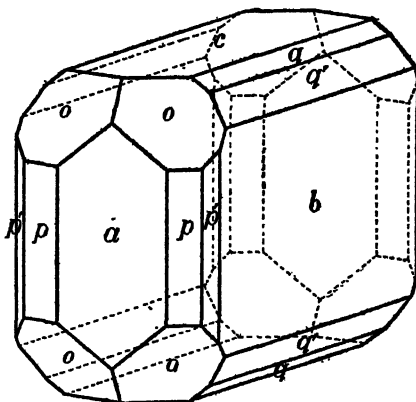

FIG. 91.—A Crystal of Cæsium Sulphate.

large amount of information, and forms a most welcome supplement to the results of the Bragg spectrometric method. Indeed, the two together afford a truly wonderful insight into even the most complicated structure. Such substances even as the alums, $R'_2SO_4 \cdot M_2'''(SO_4)_3 \cdot 24H_2O$, have been tackled by Vegard with some considerable success. One very interesting result of this work was to prove that the crystal water, here present in such large amount, forms a true part of the crystal structure, and is not tucked away in cavities, or in any other manner held or stored apart from the actual structure of the crystal.

One of the most important results of this new mode of crystallographic research by means of X-rays is that it has proved absolutely and incontrovertibly the correctness and value of the use of molecular volumes and topic axial (molecular distance) ratios, as relative measures of the unit space-lattice-cell volumes and

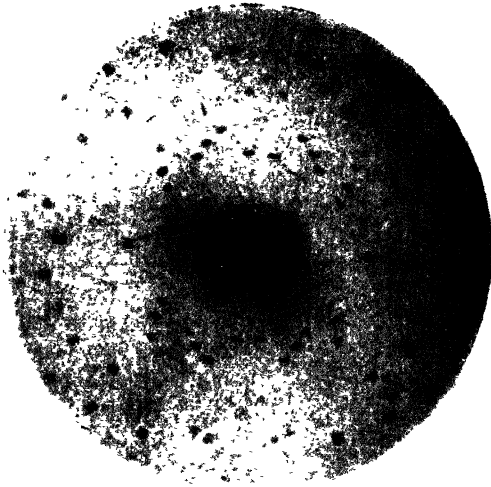

FIG. 87.—Topaz. Plate parallel (001)

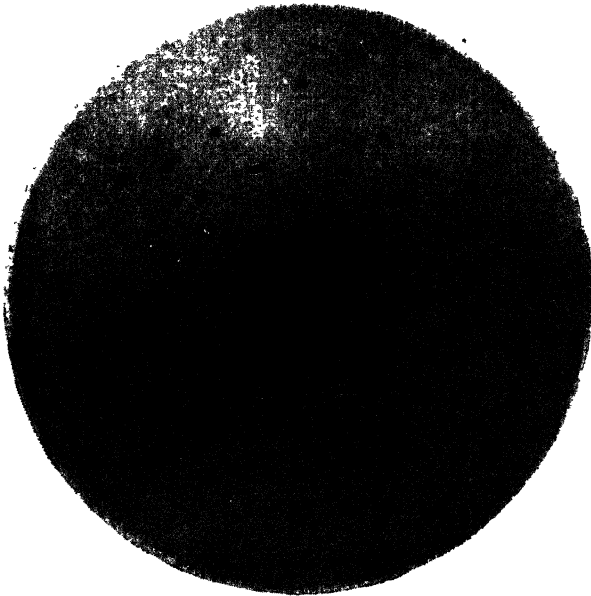

FIG. 88.—Anhydrite. Plate parallel (001)

directional (edge) dimensions, in the cases of the members of isomorphous series of crystallised substances, for which the space-lattices are of identical type, as described on pages 104 and 105.

For the absolute measurements of the cell edges (spacing of atomic planes) of such substances by means of the X-ray spectrometer have confirmed the relative measures—the molecular volumes and topic axial ratios—published by the author, in a truly wonderful manner, in the cases of the rhombic alkali sulphates referred to on page 105. The sulphates of potassium, rubidium, cæsium, and ammonium, R_2SO_4 , where R stands for the alkali metal K, Rb, Cs, or the radicle base NH_4 , have been worked out on the X-ray spectrometer in the laboratory of Sir William Bragg, by Prof. Ogg and Mr. F. L. Hopwood¹, employing the same crystals as have been used in the author's own investigations. Two typical specimens of these crystals are shown in Figs. 90 and 91, the former representing potassium sulphate K_2SO_4 , and the latter cæsium sulphate, Cs_2SO_4 . The exact edge-dimensions of the rectangular rhombic unit cell of the space-lattice, shown in Fig. 92 have been determined for each of the four salts in absolute lengths in space, and

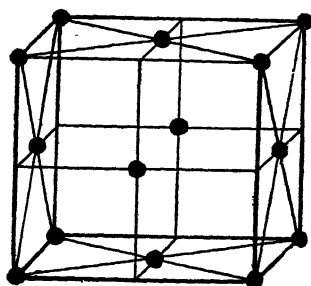

FIG. 92.—Unit Cell of rhombic Alkali Sulphates.

have been found to bear the same ratios as the topic axial ratios given in the author's memoirs, the agreement being practically perfect. Similarly, the absolute volumes of the unit cells are related to each other precisely as the molecular volumes published by the author, to the same degree of close agreement. Incidentally the X-ray analysis has also confirmed the author's result that the ammonium and rubidium salts of this series of sulphates and selenates are isostructural, the absolute volumes and cell-edge-lengths being practically identical, as were the author's molecular volumes and topic axial ratios for these two salts of either group. The confirmation is of some importance, inasmuch as according to the valency volume theory of Barlow and Pope, so far from being isostructural, the volume of the unit cell of the ammonium salt should be at least twice as great as that of the rubidium salt, for there are 24 unit valency volumes in $(NH_4)_2SO_4$ and only 12 in Rb_2SO_4 . Any thought of possible lack of strict comparability, which the author had shown to be really set aside by the especial ease with which the two salts form mixed crystals (a very trustworthy sign of congruency), is thus put altogether out of court, and the fact of

¹ *Phil. Mag.*, 1916, **32**, 518.

the isostructure of the two salts is proved beyond all question. This investigation by means of X-rays would thus appear to have afforded the decisive evidence against the valency volume theory.

The main difference between the methods of Laue and of Bragg is that general ("white") X-rays involving considerable range of wave-lengths are used in the former photographic method, while "monochromatic" X-rays (that is, of a specific wave-length) are used in the latter spectrometric method.

Yet a third method of procedure in X-ray analysis has, however, been devised independently on the one hand by P. Debye and P. Scherrer, and on the other by A. W. Hull, the essential peculiarity or innovation of which is that crystal powder is employed instead

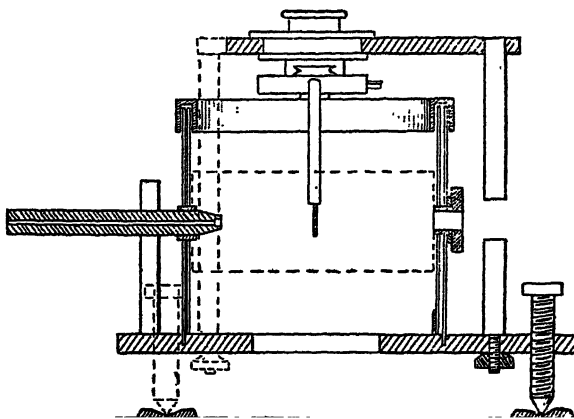

FIG. 93.—Apparatus of Debye and Scherrer.

of a single well-developed crystal. The crystalline powder is compressed into a small rod, which is placed in the axis of a cylindrical camera and photographic film, and subjected to "monochromatic" X-rays. On developing the film it is found to exhibit characteristic curves, due to those crystal particles, among the infinite variety present, which happen to be correctly situated (on a hollow cone) to reflect the X-rays from their planes of atoms. Instead of obtaining a disordered mass of impressions, very definite curved lines are alone found, afforded by these fortuitously conveniently placed particles, and their interpretation has proved unexpectedly simple. Results with crystals already studied by the Laue and Bragg methods afforded fully confirmatory conclusions as regards the crystal structures. Moreover, a large number of substances which cannot be obtained in good crystals, such as graphite and metals, have been investigated with great success by this method. The apparatus of Debye and Scherrer is shown in Fig. 93.

More recently Sir William Bragg has adapted the powder method for use with his X-ray spectrometer, the crystal powder being merely pasted on a flat surface, which is then arranged on the spectrometer crystal holder instead of a crystal.

Among the most interesting of the substances studied by this third method is graphite. This second crystalline form of carbon differs from the diamond in being of trigonal instead of cubic symmetry, but of hexagonal habit, formed by four simple equilaterally triangular prismatic lattices, the structure somewhat resembling the bee-cell arrangement, the carbon atoms being situated at the corners of regular but puckered hexagons arranged in parallel strata, the distance between any two layers being much

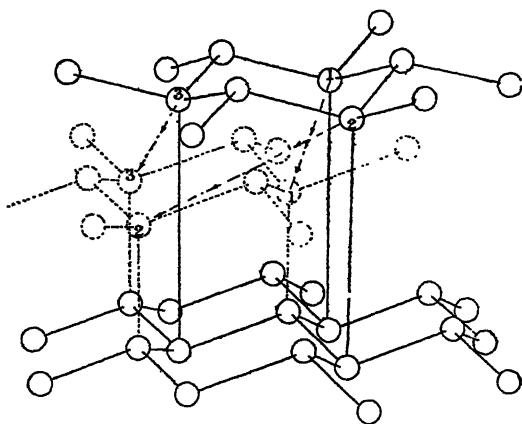

Fig. 94.—Conversion of Diamond to Graphite Structure.

greater than that between adjacent atoms in the strata. The result is that there is a cleavage parallel to the strata of so pronounced a character that graphite is not only soft and flaky, but acts as a lubricant. For the cohesion between the relatively widely separated strata is obviously much less than that between the atoms in any particular stratum. On the other hand, the cubic diamond is the hardest substance known.

Now the most interesting fact of all is that this structure of graphite can be converted into that already described on page 122 for diamond by simply moving the strata of graphite closer together, while at the same time giving them a certain amount of rotation.

The structure of graphite is represented by the continuous lines in Fig. 94. If now the top layer in the figure be moved to the lower, closer and rotated, position, shown in dotted lines, the structure of diamond is afforded. Conversely, by opening up and rotating the puckered layers of the diamond (see the Fig. 80 of a

diamond model) the structure of graphite is produced. Moreover, the chemical significance of these facts is further emphasised by the evidence adduced by Sir William Bragg in his most recent work that these hexagonal rings of the diamond, which persist in graphite, do so also in the aromatic organic compounds. He

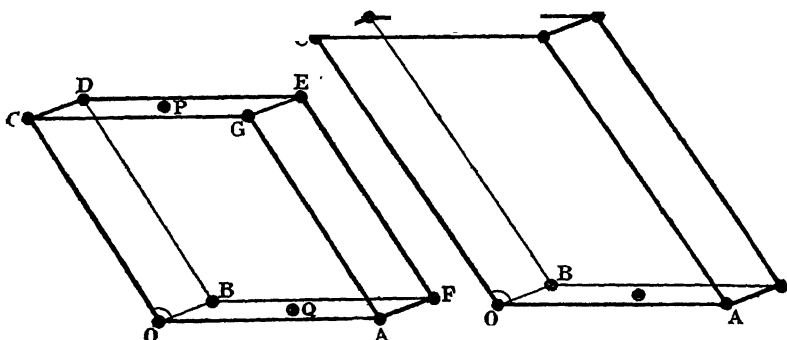

FIG. 95.—Unit Cells of Naphthalene and Anthracene.

shows that benzene itself, C_6H_6 , which is difficult to investigate crystallographically, as it melts at $6^\circ C.$, is probably such a simple hexagonal more or less puckered ring of carbon atoms with attached hydrogen atoms, while naphthalene, $C_{10}H_8$, which is well known to be constituted of double benzene rings and is a well-crystallising

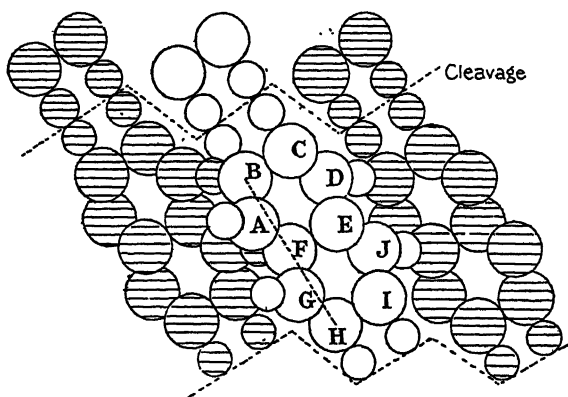

FIG. 96.—The Structure of Naphthalene.

substance, has been fully investigated by the X-ray spectrometer and found to have a structure which is built up of just such double rings acting as entities. Further, anthracene, $C_{14}H_{10}$, is equally well known to consist constitutionally of triple benzene rings, and these also appear to be present in its crystals as separate entities.

The structure of naphthalene and of anthracene, as regards the

shape of the elementary cell of the space-lattice of each structure, is shown in Fig. 95, and Fig. 96 shows three naphthalene molecules and parts of others. Both hydrocarbons crystallise in monoclinic prisms with perfect basal cleavage. It was found that, in the case of each hydrocarbon, two molecules were contained in the unit monoclinic cell of the space-lattice structure. For besides a molecule at each corner of the cell there is also one at the centre of each basal plane face (001). Only one-eighth of a molecule is assignable to any particular cell, such as that drawn in Fig. 95, the whole eight corners thus together corresponding only to one molecule, while each molecule at the centre of the basal plane contributes half to each of two adjoining cells, the two halves, above and below, thus accounting for the second of the two molecules which go to a cell. The absolute dimensions of the cells of both naphthalene and anthracene were determined by the X-ray spectrometric method, and found to be just such as would be accounted for if we accept that the double-ring molecule of naphthalene is replaced in anthracene by a three-ring molecule in each case. Hence, Sir William Bragg concludes that the double or triple ring molecules lie with their greater length parallel to the vertical axis (inclined in the figure), and that the anthracene cell is longer than that of naphthalene for this very reason, and to exactly the calculated extent. The plane of the molecules, he concludes, is parallel to the symmetry plane (010), the plane of the paper in the figures.

The β -hydrogen atoms of one molecule, those at the ends of the molecule, as indicated in the adjacent constitutional formula, appear to lie adjacent to those of the corresponding ones of the next molecule, and the symmetry plane (010) appears to pass through them, while the α -hydrogen atoms, those of the sides of the double- or triple-ring molecule, lie up against the carbon atoms of the neighbouring molecules, there being just about the right amount

of space for them. The forces between the β -hydrogen atoms are weaker than those between the α -hydrogen atoms and the carbon atoms, and both are feebler than the valency forces which hold the carbon rings together, yet they are sufficiently strong to bind the double- or triple-ring molecules together in the crystal structure. Observations also with several of the derivatives of naphthalene have fully confirmed these conclusions.

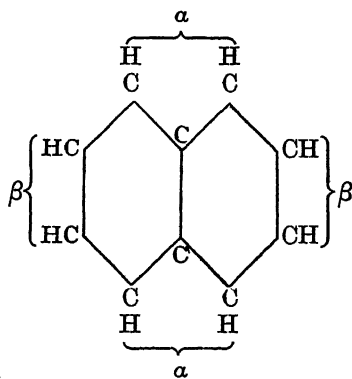

The most striking deduction from these results with aromatic organic compounds is that there is absolute certainty that the molecule remains an entity in the crystal structure, so that the sweeping statements which were made shortly after the first results of the new mode of investigating crystals by means of X-rays, that there are no molecules in crystal structures, which is one of atoms only, is, as was strongly foreshadowed by the author, quite erroneous. The forces which bind atoms together in crystals are clearly of more than one kind. The very strong valency bonds, due to direct combination between electropositive and electronegative elements, as in the case of common salt or of potassium chloride, described in Chapter X, page 89, or due to electron sharing in the case of two electronegative elements, are obviously of a different character to the linkages or bonds between the α -hydrogen atoms of one naphthalene molecule and the carbon atoms of the next, or the still weaker ones between the end-to-end β -hydrogen atoms. In these latter cases the attachments are clearly made at definite points on the molecules, and probably at short range, and they lock the parts of the crystal structure together as firmly as do the bolts and rivets of an engineering structure.

It would appear as if all the carbon atoms in the diamond are held tightly together by valency forces, all four valencies acting similarly, while in graphite only those in the strata are thus firmly held, the fourth valency between the atoms of different strata being of a much weaker character, this weaker attachment resembling more closely that between the molecules of an organic compound and corresponding to a remarkably weak cohesion, so that the crystals of graphite cleave with great readiness parallel to the strata. In the case of so simple a binary compound as potassium chloride it is not possible to recognise the molecule in the crystal structure, which is essentially one of the "ions" (the atoms with their complete argon shells and consequent positive and negative electric charges) of potassium and chlorine, alternately arranged at the lattice nodes. Yet even here there can be no doubt that it was by the separation of molecules out of the metastable super-saturated (and therefore not electrolytically dissociated) solution, and their deposition in orderly ranging, that the crystal edifice was constructed. Also that on again dissolving the crystal in water, the reconstituted molecules are what go into solution.

One of the latest substances investigated (May, 1922) by Sir William Bragg is ice, as described on page 124, and it also belongs to the class of crystals in which the molecule appears to be lost and broken up into positive and negative ions. The hydrogen atoms have given up their valency electrons (the single one of each atom) to the oxygen atoms, each of which can receive the two

electrons from two hydrogen atoms. There are thus twice as many hydrogens around each oxygen atom as there are oxygens, corresponding to the molecular composition of water, H_2O . The structure had already been shown by A. St. John and by D. M. Dennison to consist of a hexagonal lattice composed of four interpenetrating trigonal prisms: and F. Rinre had shown the class to be hexagonal bipyramidal, class 25, that of apatite (see page 24). Sir William Bragg shows that the oxygen atoms are surrounded at equal distances by four other oxygen atoms, and that this regular structure is a very open one, so much so that a loose (liquid) arrangement of water molecules would occupy less space, so that pressure should melt ice (as it does), and the water flowers with their vacuole (bubble of water vapour) produced on passing heat rays through a slab of ice, as described on page 31 and illustrated in Fig. 35, are strikingly explained.

One of the most interesting and important cases of the successful determination of crystal structure by means of X-rays is that of tartaric acid, and it is remarkable that it was effected by Mr. W. T. Astbury in the laboratory of Sir William Bragg, in the centenary year, 1922, of the birth of Louis Pasteur, at Dôle, in the French Jura. Indeed, the paper describing it was read to the Royal Society within a few days of the exact date of Pasteur's birthday, December 27th. The celebrated research of Pasteur on tartaric acid $C_4H_6O_6$ is described on pages 156 to 159, and drawings of crystals of the two varieties, right-handed and left-handed, of the substance are given in Figs. 105 and 106 on page 158. It is highly satisfactory that this X-ray analysis of tartaric acid crystals has fully substantiated the character and general structure which were attributed to it by Pasteur, and that some remarkable optical peculiarities exhibited by the substance are accounted for by the details of the structure which have been established. Moreover, the exact details of the structure have been fixed and the dimensions of the crystal unit cells of the space-lattice determined in absolute measure.

The crystals belong to the sphenoidal class 4 of the monoclinic system, their elements being $a : b : c = 1.2747 : 1 : 1.0266$ and $\beta = 100^\circ 17'$. Their density is 1.759. The dextro variety, as explained on page 158 and as shown in Fig. 105, is distinguished by the development of only the right clino-prism (011), and the lævo-variety by the complementary (enantiomorphous) development of only the left clino-prism (0 $\bar{1}$ 1). The first result of the X-ray spectrometric measurements was to show that the crystal unit is composed of two molecules of $C_4H_6O_6$. The arrangement of the atoms of carbon, hydrogen and oxygen composing them is shown in Fig. 97. The two longer portions (a) and (b) show the arrangements in dextro- and lævo-tartaric acid respectively, the horizontal lines

being parallel to axis a ; and the smaller portions (a') and (b') underneath each represent the end view of each. The next, Fig. 98, shows a section of the crystal unit perpendicular to axis a , and the

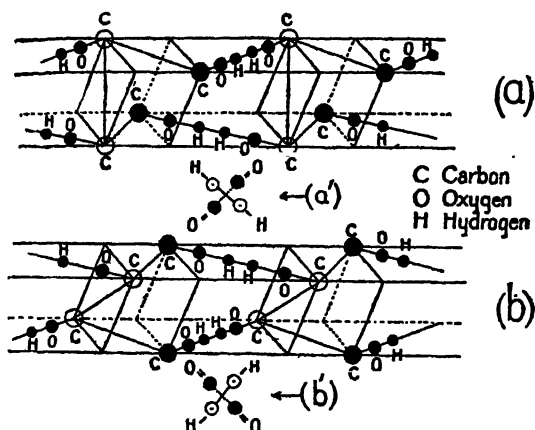

FIG. 97.—Tartaric Acid: (a) dextro, (b) lævo; (a') and (b') corresponding cross-sections.

arrangement of the molecule at each corner and its digonal complementary molecule at the centre.

The spiral character of the 2 enantiomorphous structures, and the fact that they are of opposite winding, will be clear from Fig. 97. The 4 carbon atoms of each molecule are situated at alternate corners of the oblique parallelepiped, and this automatically produces an irregular spiral formation within the molecule itself. Moreover, the hydroxyl groups are arranged in another spiral of opposite kind, and the molecules are held together, end to end, in the crystal lattice by forces between the H atoms of adjacent hydroxyl groups, one OH group being carboxylic (COOH) and the other alcoholic (CHOH).

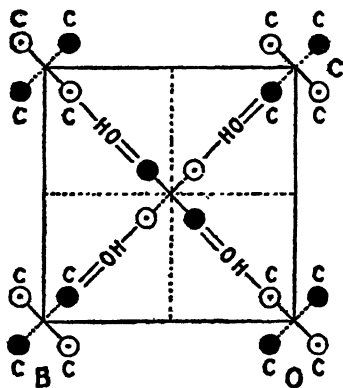

FIG. 98.—Tartaric Acid. Section of Crystal Unit.

This second twist reverses that of the first, and inverts the order of succession of the —H, —OH, and —COOH groups around the two asymmetric carbon atoms which are so dominant in tartaric acid. The final conclusion is that the dextro rotatory power of ordinary tartaric acid, or the lævo-rotatory

power of the other variety of the acid, is due solely to the presence within the molecule of a system of 4 C atoms forming an irregular spiral, the winding of which is opposite in the two varieties. A clockwise spiral of atoms produces dextro rotation (meaning that the plane of polarisation of light is rotated to the right from the point of view of a person looking into the polariscope), and an anti-clockwise spiral lævo-rotation. In dextro tartaric acid the order of sequence of the —H, —OH, and —COOH groups is anti-clockwise, as we look towards the asymmetric carbon atom in the direction leading towards it from its companion asymmetric C atom.

The general conclusion of Pasteur, and of later workers, as to the essential characters of the two varieties and their relations to the optical activity of this typical enantiomorphous substance, are thus absolutely confirmed and substantiated beyond a shadow of doubt.

Mr. Astbury has followed up this interesting research on the structure of tartaric acid by a similar investigation of racemic acid, the inactive substance of the same chemical composition, $C_4H_6O_6$, which Pasteur, as described on pages 156 and 158, showed to be a molecular compound of the two optically active, dextro and lævo, varieties of tartaric acid, forming the typical case of optical inactivity by external compensation. The ordinary racemic acid, obtained by crystallisation at the ordinary temperature, crystallises with a molecule of water of crystallisation in the pinakoidal class 2 of the triclinic system.

But a second, anhydrous, form, which is also, but differently, pinakoidal triclinic, is obtained by crystallising from solutions maintained at $73^\circ C.$, as first shown by Scacchi, and it is this anhydrous racemic acid, $C_4H_6O_6$, which is more directly comparable with tartaric acid, that Mr. Astbury has investigated by means of X-rays.

The crystal elements found by Scacchi were: axial ratios, $a : b : c = 1.5228 : 1 : 1.0250$; axial angles, $\alpha = 82^\circ 20'$, $\beta = 122^\circ 56'$, $\gamma = 111^\circ 52'$. The crystals are usually thick tabular combinations of {010}, the table-plane, with {100}, {001}, $\{1\bar{1}0\}$, $\{10\bar{1}\}$, and $\{\bar{1}12\}$, and are generally very much twinned parallel to (010), indeed frequently with lamellar repetition. They cleave very perfectly parallel to both (010) and (001).

After many crystallisations some excellent single crystals were obtained suitable for the X-ray work, and the cleavage-plane faces (010) and (001) gave excellent reflections of the X-rays at their specific angles, those from (010) being quite unusually strong. The observed angles corresponded to the spacings of these planes of atoms at the following distances: $d_{010} = 4.50 \text{ \AA.U.}$ and $d_{001} = 4.17 \text{ \AA.U.}$

The crystals were found to contain two asymmetric molecules of $C_4H_6O_6$ in each unit cell, the centro-symmetry of the whole structure, corresponding to class 2 symmetry, being brought about by the interpenetration of two asymmetric lattices, each of which is centro-symmetrical to the other. This corresponds perfectly to the presence of equal numbers of right and left-handed molecules

of tartaric acid, the molecules of which have already been shown to be asymmetric. Thus the unit cell contains one right-handed and one left-handed molecule of $C_4H_6O_6$.

This unit cell, however, is not the simplest triclinic parallelepiped which can be drawn, but one double the size; the simplest cell only contains half a molecule of each variety. That is, racemic acid is not a double molecule of molecular weight 300, but a single molecule of molecular weight 150, corresponding strictly to $C_4H_6O_6$.

For the state of matters is that—regarding the simplest cell of class 2, a cube deformed from rectangularity and side equality but still a parallelepiped and having the sides $a=7.41$, $b=4.87$, and $c=4.99$ Å.U.—each corner is occupied by a molecule; but those molecules at the corners joined by the vertical c -edges

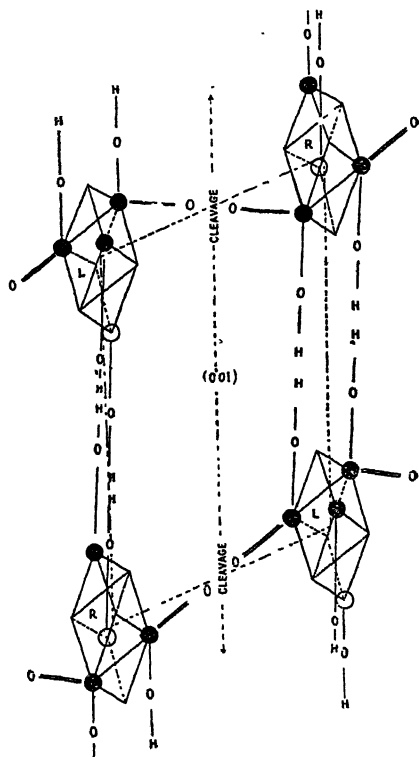

FIG. 99.—Structure of Racemic Acid in the plane (001).

are of like sign, while those joined by a and b edges are of unlike sign, an arrangement which makes one-half of the molecules, those of the same sign, to be centro-symmetrically arranged with respect to the other half.

The cleavage planes (010) and (001) are those across which there are direct molecular junctions which can be readily ruptured, the junctions being $=O : O =$ and $-H : H-$. There is no cleavage across the hydroxyl junctions, the structure being exceptionally strongly cemented at these junctions. The main length of the

tartaric acid molecule in all cases is along the a -axis of the cell, the length of which is 7.41 Å.U.

The whole arrangement can best be elucidated by two figures, Fig. 99 being that in the plane (001), and Fig. 100 that in the plane (010). In each case the black spots represent the four carbon atoms of the molecule, arranged tetrahedrally at the four alternate corners of the monoclinic parallelepiped of an active tartaric acid molecule, right or left-handedly.

This structure accords admirably with all the known properties of anhydrous racemic acid, and it is remarkable how very little distortion of the tartaric acid molecule is involved. The atomic diameters of the hydrogen atoms all work out to one Ångström unit in both tartaric and racemic acid, and the diameter of oxygen

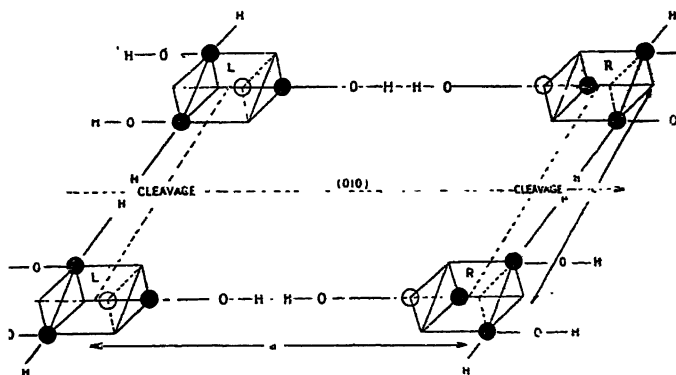

FIG. 100.—Structure of Racemic Acid in the plane (010).

is only slightly more than a unit. But the length of the molecule along the a -axis, which in tartaric acid is 7.69 Å.U., becomes shortened to 7.41 in racemic acid, the atomic diameter of carbon remaining 1.54 Å.U. This indicates a molecular contraction on mixing dextro and lævo tartaric acids to form racemic acid, and thus the observed evolution of a sensible amount of heat during the process is explained. The fact that the melting-point of racemic acid, 206° C., is much higher than that of active tartaric acid of either variety, 168°–170°, is explained by the exceptional strength of the structure across the hydroxyl junctions of the molecules, that is, across the length of the structure, the observed contraction being along this length.

It is thus most satisfactory that the analysis of racemic acid by X-rays should so completely confirm the conclusions of Pasteur, and of later crystallographers, chemists and physicists, rendering the interesting phenomena described in Chapter XIV not only at once intelligible, but indeed just what ought to be expected.

A definite law connecting the symmetry of the crystal with that of the chemical molecule has been arrived at by another of Sir William Bragg's collaborators, Mr. G. Shearer. It is as follows: The number obtained by dividing the weight of the crystal unit by the molecular weight is either equal to the symmetry number (the number of asymmetric molecules in the crystal unit) or is a sub-multiple of it; and in the latter case the number obtained by dividing the symmetry number by the number of molecules is the symmetry number of the molecule. This rule emphasises the fact that the chemical molecule is the basis of construction of the crystal unit, which is usually composed of more than one chemical molecule. It thus lays stress on the fact of the persistence of the molecule in the crystalline state. No case has yet been observed in which the number of molecules is greater than the symmetry number, but cases where it is smaller are common, these being cases in which the molecule itself possesses symmetry.

Indeed, this later work at University College, London, has given us in many cases a clue to the symmetry of the chemical molecule. For instance, in the case of naphthalene, the symmetry number is 4, but there are only 2 chemical molecules in the crystal unit; hence, the symmetry number of the molecule itself is 2, that is, it possesses twofold symmetry and no more. This has been proved to be correct by Sir William Bragg, the chemical molecule of naphthalene having been shown to have a centre of symmetry. The crystal unit, being holohedral monoclinic (prismatic), has, however, also a plane of symmetry. These facts are illustrated by Figs. 101 and 102.

We have three things to discriminate, (1) the crystal unit, usually composed of more than one chemical molecule, (2) the crystal molecule, the molecule as it exists in the crystal, and (3) the chemical molecule, as it exists in the free gaseous or liquid condition.

One further result of the utmost general importance has also been derived by Prof. W. L. Bragg from the whole of the collected results of X-ray analyses of crystals yet accumulated, namely, that the atoms of each chemical element possess the same definite diameter, if we regard the atom as a sphere of impenetrability, in all the crystal structures of the compounds containing it, or in the crystallised element itself. So that he has been able to draw up a table of atomic diameters. They may be regarded as the diametral dimensions of the exterior shell of electrons of the atom in each case, or at any rate of the spherical surface of nearest approach to contact, the sphere of influence, the atomic domain. They were actually obtained by measuring at their closest approach the distances of separation of the centres of adjacent atoms in the various crystal structures. Hence, in general, the actual distance

of separation of the centres of any two adjacent atoms in a solid crystal is equal to the sum of their radii, which is equal to the diameter of each atom when we are dealing with two atoms of the same element.

Now it is of the deepest interest to study how these atomic diameters are related, when we arrange the elements in a table



FIG. 101.
The Molecule.

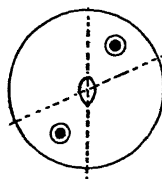
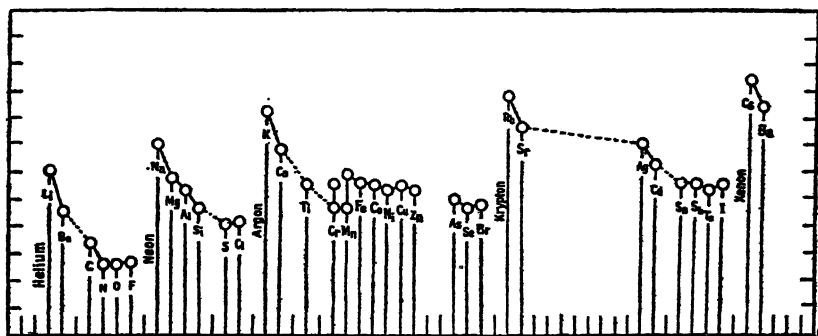

FIG. 102.
The Crystal Unit.

The Symmetry of Naphthalene.

according to their atomic numbers. The most comprehensive grasp of what occurs is best afforded by graphically expressing the table as a curve, which is given in Fig. 103, in which the atomic numbers are taken for abscissæ and atomic diameters as ordinates.

The curve is at once seen to be periodic, the electropositive



Atomic Numbers of the Elements.

FIG. 103.—The Curve of Atomic Diameter.

alkali metals standing at the maxima, which are very sharp, and the electronegative elements and the inert gases at the minima. It will be obvious that valency has nothing to do with atomic diameters, this assumption in the celebrated theory of Pope and Barlow being erroneous (see Chapter XX). The atom of the monad element, caesium, for instance, is the largest which has been measured, its diameter being 4.75×10^{-8} cm.; whereas the dyad element oxygen, and the triad element nitrogen, have only atomic

diameters of 1.30×10^{-8} cm. each. That atomic size does influence crystal structure, however, was a sound idea on the part of Pope and Barlow, and a previous suggestion by Sollas, that it was the atomic volume of Lothar Meyer which expressed the size of the atoms of the various elements in crystals, was very near the truth, for the well-known curve of Lothar Meyer is similar in general appearance to that of atomic diameters, but it differs considerably in details. The truth is now known to be expressed by the curve of atomic diameters of W. L. Bragg.

The Law of Atomic Diameters also obviously supplements the law of Moseley in furnishing the reason for the author's law of progression of the crystal properties in eutropically isomorphous series, and this statement may be added as a rider to the conclusion arrived at in the penultimate paragraph of the preceding Chapter XI. The outstanding size of the atoms of the alkali metals, so clearly shown by the sharp maxima of the curve, Fig. 103, and also the considerable progressive increase in the atomic size as we pass from potassium to rubidium and from the latter to cæsium, corresponding to the addition each time of a double-period shell of 18 electrons, explain and render more important this law of progression derived by the author from the study of the rhombic alkali sulphates and selenates, $R_2\overset{S}{\text{Se}}\text{O}_4$, and the monoclinic series of double sulphates and selenates, $R_2M(\overset{S}{\text{Se}}\text{O}_4)_2 \cdot 6\text{H}_2\text{O}$, in which R is potassium, rubidium, and cæsium. For the choice of these series is shown to have been the best that could possibly have been made in order to obtain results far removed from the possibility of error, these alkali metals not only affording the chance of the greatest differences being exhibited when the metals are interchanged for one another, but also exerting a dominating influence in the case of the double salts, the effect of the M dyad-acting metal being far less, in accordance with its minimum position in the curve. The choice, in fact, gave the maximum opportunity for obtaining a definite result, as to the crystallographic effect of the replacement of one element of the same family group by another. The law itself—that a well-marked progression in the crystal angles and elements, the habits of the crystals, the dimensions of their space-lattice unit cells, their refractive indices and molecular refractions, the amount of the double refraction, and in other details of the optical properties, as well as in the thermal dilatations of the crystals, is observed when potassium is replaced by rubidium, and the latter in turn by cæsium—is just what could be expected from the positions of these three alkali metals in the curve of atomic diameters. The author's investigations thus agree perfectly with the results of

X-ray analysis, not only, as already shown, by the wonderful agreement between the absolute measurements of the rhombic sulphates in Sir William Bragg's laboratory and the relative dimensions previously published by the author, but also, as regards the large double-salt series as well as the simple salts of both sulphuric and selenic acid, in fulfilling the natural expectations which the law of atomic diameters would raise.

The law of crystallographic progression in isomorphous series and the law of atomic diameters are thus in complete agreement, and mutually support one another. Much other outside evidence from quite different quarters has also recently been adduced in further support of the law of atomic diameters, so that, although further work will doubtless perfect the accuracy of the actual numbers, the general truth of the law is now assured.

The main results of this wonderful new method of crystallographic research by X-rays may now, therefore, be summarised as follows :

Direct experimental proof is afforded that in crystals the structural units, the component chemical atoms and their molecular or polymolecular groups, are arranged in one or other of the 14 space-lattices as regards the main grosser structure (that of points representative of the molecule, or small group of molecules), and in one or other of the 230 point-systems as regards the ultimate units, the chemical atoms themselves. The direct proof afforded includes confirmation of the fact that the ultimate point-system (one of the 230) which constitutes the unlimited regular crystal structure may be correctly considered as being built up by the regular interpenetration of space-lattices, each of the latter consisting of one and the same kind of atoms only, that is, being composed of the same chemical element. The atoms in their point-system are thus proved to be in very truth the ultimate units of the crystal structure, but the whole details of the structure are included in the grosser unit, the chemical molecule, or small group of two, three, four or (possibly, but unlikely) more molecules, the representative points of which (say, any one atom chosen analogously from each molecule or group, or the centre of gravity of the molecule or group), form the space-lattice. So that one of the most important results of the X-ray analysis of crystals which have now been carried out has been to show that the crystal structure revealed conforms to one or other of the 230 space-groups (types of homogeneous structures), the possible existence of which has been indicated by Schoenflies, Fedorov, and Barlow. Indeed, most of the structures found have corresponded to one or other of the 65 more fundamental regular point-systems of Sohncke, or to the special cases, or in the simplest cases to the still more fundamental 14 space-lattices of Bravais, to which the point-systems become eventually reduced.

A valuable memoir, by R. W. G. Wyckoff, has been published by the Carnegie Institute of Washington, in which the special cases of the 230 space-groups have all been worked out. For the number of atoms contained in the unit cell of the space-lattice has, in general, proved to be smaller than the number of most generally placed equivalent points of the space-group having the symmetry of the crystals, so that the special arrangements of the equivalent points (on axes, planes, or other symmetry elements), whereby the number of symmetry elements is reduced, are of especial importance to the X-ray analyst.

There are two distinct types of crystal structures, even among very simple compounds. We have first those in which the positions of all the atoms of the different chemical elements present are definitely fixed in the structure by the symmetry revealed, as in the cases of sodium or potassium chloride and zinc blende, the atoms being fixed at the corners or centres of cubelets. In the other type only the atoms of one or more of the elements present are so fixed, at immovable positions on the nodes of the lattice or centres of their cells or cell-sides, while the positions of the other atoms are permitted a certain amount of latitude by the symmetry, the exact position, for instance along a particular line such as a diagonal, being determinable by the quantitative Bragg X-ray spectrometric method. Iron pyrites, FeS_2 , and calcite, CaCO_3 , are instructive examples of this second more difficult type, the positions of the sulphur atoms of the former and of the oxygen atoms of the latter requiring such special determination. Considering iron pyrites as a typical example, if we turn to Fig. 79 on page 121 representing zinc blende, we can truly imagine it to be iron pyrites if we take the black spots at the corners and face-centres of the large cube to be iron atoms instead of zinc atoms, and imagine the alternately arranged diagonals of all the eight cubelets, one diagonal in each cubelet, to be occupied by sulphur atoms, and not merely four cubelets only as in zinc blende; for there are twice as many sulphur atoms in pyrites, FeS_2 , compared with ZnS . But the sulphur atoms are not now at the centres of the diagonals and the cubelets, but have been shown by Sir William Bragg to lie at positions about a quarter of the length of the diagonal from the empty cube corner in each case. It is by the careful determination of such positions of atoms, not fixed by the symmetry itself, that Prof. W. L. Bragg has been able to determine the diameters of many of the elementary atoms. For instance, the diameter of the atom of sulphur has been found to be 2.05 Angström units, from the nearest positions of approach of two atoms of the element along these cube diagonals of iron pyrites.

There is a certain amount of confirmative evidence also offered by the X-ray investigations with crystals that the chemical forces

which hold together the atoms composing the chemical molecules are still operative even in the solid crystal, although the purely geometrical facts do not require such forces, as the structure is essentially and ultimately one of atoms. The remarkable structure found by the Braggs for the diamond is a case in point, especially when considered in relation to the interesting research by Debye and Scherrer¹ on graphite, described on page 131, which revealed the fact that the carbon atoms are here situated at the corners of regular hexagons arranged in parallel strata, the fourth valency of the carbon atom being apparently almost latent, while three only are operative, instead of there being four equal valencies arranged tetrahedrally in the case of the diamond. From the persistence of this graphite structure in the aromatic compounds of carbon, it would appear that the two allotropic forms of carbon, trigonal graphite and cubic diamond, correspond respectively chemically to benzene and its immense number of derivatives, and to the fatty and inorganic compounds of carbon. Indeed, it is becoming more and more clear that the early and hasty view of the geometricians, that it was no longer necessary to consider the molecule at all in connection with the solid crystal, is untenable, and that the intra-molecular, interatomic, connections remain unimpaired although not readily recognisable. Some further strong evidence, from quite another point of view, of the preservation of the chemical molecule in the crystal, has also more recently been offered by Beckenkamp.²

The evidence of so unimpeachable and truly remarkable a character, afforded by the X-ray analysis of crystals, has thus entirely confirmed the principles concerning the nature of crystal structure which have been laid down in this book; it has placed the work of the crystallographer on a thoroughly established and truly firm basis, and rendered it more valuable from every point of view. Above all it enhances the value of crystallographic study to the chemist and the physicist, and vastly intensifies the importance of a knowledge of elementary goniometry to all students and investigators in this domain of natural science.

Lastly, the very latest X-ray researches of Sir William Bragg in London, and of Prof. W. L. Bragg in Manchester, have gone beyond the structure of the crystal to that of the structure of the atoms composing the crystal, by two independent methods. Sir William Bragg has obtained evidence, from renewed and much more detailed study of the higher order X-ray spectra reflected from the diamond, that connecting electrons tetrahedrally arranged on the outer shells of electrons are what hold the atoms of carbon together. Also in fluorspar he has located connecting electrons about one-third the way between the calcium and fluorine atoms. The calcium atoms

¹ *Phys. Zeitschr.*, 1917, 18, 291.

² *Centralbl. f. Min.*, 1917, 97.

occupy the nodes of the main face-centred cube; and the fluorine atoms the centres of all the eight cubelets of the main cube.

Prof. W. L. Bragg, by using X-rays already purified and rendered more truly monochromatic by preliminary reflection from a crystal of rock-salt, has been able to get much more accurate determinations of the intensity of these pure rays when reflected from a second crystal of rock-salt or of some other substance. He has combined these results in a formula for the reflecting power of a plane of atoms, which also embodies the results of Debye and Scherrer, of Darwin and Compton, and of Sir William Bragg. This formula has a factor which depends entirely on the arrangement of the electrons about the atomic nucleus, and the results of the whole research show that the values for this factor agree with the supposition that the electrons do really lie on shells, and are in oscillation about mean positions along lines joining them to the nuclear centre. That is, that the atoms have positions on the shells which are definite within certain limits, and which agree more or less with the Bohr version, but best with the Lewis-Langmuir version of the atomic structure theory, just as do the locating results of Sir William Bragg for diamond and fluorspar above referred to. Doubtless further work will bring the two versions into agreement as to the details, just as they are already in line as to the general nature of the structure of the atom.

Thus has crystallography at length led directly to an experimental proof of the accuracy of the atomic structure theory, and actually revealed the existence of the outer electrons on their shells.

CHAPTER XIII

POLYMORPHISM AND ITS EXPLANATION

It has been shown in Chapter VIII that Mitscherlich had in several instances proved the possibility of the occurrence of the same substance in two different forms, notably sodium di-hydrogen phosphate $\text{NaH}_2\text{PO}_4 \cdot \text{H}_2\text{O}$, calcium carbonate CaCO_3 (as calcite and aragonite), the metallic sulphates known as vitriols, and the chemical element sulphur, and that he gave to the phenomenon the name "dimorphism." Since that time large numbers of dimorphous substances have been discovered, and several which occur in three forms and even a few in no less than four totally distinct forms. Until the establishment of the geometrical theory of crystal structure, as expounded in Chapter X, this phenomenon of polymorphism gave rise to endless fruitless discussion. It was most generally attributed to the different nature of the so-called "physical molecule," which was supposed to be an aggregate of chemical molecules and the unit of the space-lattice determining the crystal system; the different polymorphous varieties were supposed to be built up of structural units or physical molecules consisting of an aggregation of a different number of chemical molecules. This is true as regards the undoubted fact that the unit of the space-lattice is not usually the single chemical molecule, but is more generally a small group of molecules, such as two, three, or four; for instance, it is composed of four molecules in the case of the rhombic sulphates of the alkalis, as proved by X-ray analysis. Several attempts were made by various investigators, notably by Muthmann and by Fock, to determine the number of chemical molecules constituting the physical molecule. All these efforts, however, ended unsatisfactorily.

In the year 1896 the author showed, in a memoir¹ on "The Nature of the Structural Unit," that in general the physical molecule is a myth, and that the chemical molecule is the only molecule in the true sense of the word. It may, however, require more than one molecule to produce the unit possessing the full crystal structure, the unit cell of the Bravais space-lattice containing possibly more than one molecule. It has since been proved, as one of the

¹ *Journ. Chem. Soc.*, 1896, **69**, 507.

most interesting results of the new X-ray analysis of crystals, that this is really the case in certain specific cases which have been thoroughly worked out, notably that just mentioned of the rhombic sulphates of potassium, rubidium, caesium, and ammonium, in which case four molecules go to the unit cell. The four molecules are so arranged with respect to each other as to produce, by the total number of their atoms, $4R_2SO_4$, the atomic point-system (that one of the 230 possible systems) which is actually present in the crystal. The centre of gravity of the unit cell, or better, any representative point within it, such as a particular atom, may be considered as the unit point of the Bravais space-lattice of the crystal structure, while the atoms of which the chemical molecule, or group of molecules, are composed, arranged stereometrically in the molecules, are the points of the particular point-system (of the 230) which is developed. This does not imply a necessarily parallel and identically orientated arrangement of the molecules, as at first postulated by Sohncke and which is a fact for his sixty-five point-systems; for in accordance with the conclusions of Schoenflies, Fedorov, and Barlow discussed in Chapter X, cases are possible in which alternate molecules may be arranged as each other's mirror-images. Such are the cases of external molecular compensation or molecular combination, as in racemic acid, two oppositely enantiomorphous sets of molecules balancing each other within the structure, but by exterior compensation as regards the molecule itself. Moreover, the principle of mirror-image symmetry enters, as stated in Chapter X, altogether into the constitution of no less than 165 of the 230 types of homogeneous structure possible to crystals.

The alkali sulphates and selenates, which are thus found to have four chemical molecules in the space-lattice cell, exhibit dimorphism, one member of the series, ammonium selenate, having only hitherto been observed in the pure state in the second, monoclinic, form, and never in the ordinary rhombic form; the author has, however, obtained rhombic mixed crystals of ammonium and rubidium selenates containing as much as 60 per cent of the ammonium salt, owing to the close approximation of the topic axial ratios. In the case of the double salts which they form with the sulphates and selenates of magnesium, zinc, iron, nickel, cobalt, manganese, copper, and cadmium, the author has shown that the chemical molecule is already so large and complex, namely, $R_2M\left(\overset{S}{\underset{Se}{O_4}}\right)_2 \cdot 6H_2O$,

that only one such molecule, or at most two molecules, is or are contained in the unit space-lattice cell, and that its representative points are, as just stated, the nodes of the Bravais space-lattice of the crystal structure, determining both the system of the crystal and its obedience to the law of rational indices.

The explanation of polymorphism proves, in the light of these results which have now been laid before the reader, to be a remarkably simple one. Special pains were taken in explaining those results to show that the temperature had a great deal to do with the conditions of equilibrium of the crystal structure, for it determines the intermolecular distances, that is, the amount of separation of the molecules, and thus controls their possibility of movement with respect to one another. Now the behaviour of the chemical molecules on the advent of crystallisation is undoubtedly largely influenced by the stereometric arrangement of the atoms composing them, and it is possible for the latter to be such that the molecules may take up several different parallel or enantiomorphously or otherwise related positions; or, as we have just seen, a regular alternation within the crystal structure of such mirror-image positions may be taken up. These different arrangements—whether the molecules are parallel or enantiomorphously opposite, or otherwise grouped—may be, and probably will be, of different degrees of stability, each of these different forms finding its maximum stability of equilibrium at some particular temperature, which is different for the different varieties. Hence, at a series of ascending or descending temperatures, assuming the pressure to remain the ordinary atmospheric, these different types of homogeneous crystal structures will be most liable to be produced, each at its own particular temperature, for which stable equilibrium of that crystal structure occurs.

These different assemblages are as a rule quite dissimilar, certainly in the crystal elements, often in class and not infrequently in system. Generally two such different crystalline forms are all that are possible within the life-range of temperature of the substance. But occasionally three or even as many as four such different forms are found to be capable of existence within the temperature life-limits of the substance.

Polymorphism is thus completely and simply explained as a direct result of the establishment of the geometrical theory of crystal structure as laid down in Chapter X. The equilibrium of the homogeneous structure is a function of the temperature, and the stereometric arrangement of the atoms in the chemical molecule of a substance, and the different possibilities as to mode of grouping of the molecules in the unit cell, when more than one molecule occupies it, may be such as permit of two or more homogeneous arrangements of the molecules in assemblages of varying degrees of stability, but each of which has a maximum stability at a particular temperature. Hence, within any given range of temperature such a substance will assume that type of homogeneous arrangement of its molecules and atoms in a crystal which corre-

sponds to the stablest equilibrium within these temperature limits, assuming the pressure constant within the bounds of the usual atmospheric variations. Employing the language of physical chemistry, such a substance will thus present two or more different solid "phases," each characterised by its specific crystalline form, the elementary parallelepipedon of which is quite a distinct one. Each phase possesses also its own specific optical and other physical properties, such as melting point, solubility, thermal expansion, and elasticity.

The idea, however, of the formation of a specific crystalline homogeneous structure, merely because the mechanical fitting-in of the molecules occurs with the minimum of trouble or maximum of ease for this particular type of all the 230 possible types, without any directive intervention of the molecular forces, is certainly not a reasonable one.

Moreover, many soft crystals, even such as calcite, which are only relatively soft, attaining the position of as much as four in the scale of hardness, readily exhibit the property of being deformable upon glide-planes. The molecules in these cases have been shown to undergo a movement which has two components, a transference and a rotation, both of which require space, a fact which has been thoroughly substantiated by optical investigations of the parts of the crystal concerned before and after gliding. There cannot, therefore, have been merely "fitting-in" of the molecules, but their orientated positions must have been determined and maintained by the organising force, which is probably physical (connected with the forces in the fields surrounding the molecules, and due ultimately to the outer electrons of the composing atoms) rather than chemical, but is nevertheless the cause of crystallisation; it draws the molecules within a certain range of each other, corresponding to and dependent upon the temperature, causes or enables them to arrange themselves in the marshalled order of the particular type among the 230 possible arrangements, which possesses the maximum stability at this temperature, and keeps them at the same time from approaching nearer to each other than within these prescribed limits corresponding to the temperature. It is doubtless within these limits that gliding can occur parallel to such planes as leave the molecules most room for the purpose, and which are directions of least resistance.

Connected with this important question is the principle enunciated by Bravais, as a result of his discovery of the space-lattice, that cleavage occurs most readily parallel to those net-planes of the space-lattice which are most densely strewn with points. The force just referred to, whether we term it cohesion or otherwise, is obviously at a maximum within such a plane, and at a minimum in the

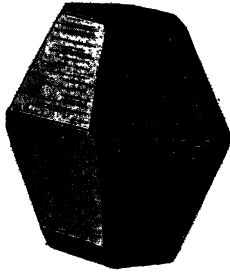

FIG. 104.—A Crystal of Sulphur, the usual rhombic form



FIG. 113.—Photomicrograph of Graphic Granite
(See page 177)

perpendicular direction where the points are further off from each other. Moreover, it has been fairly well proved also, from the experiments of Wulff, described in Chapter VI, page 50, that the direction or directions of maximum cohesion are those of slowest growth of the crystal; so that faces parallel to those directions become relatively more extended owing to the more rapid growth of other faces on their boundaries, and thus become the most largely developed and confer the "habit" on the crystal. All these are facts so important as evidences of a controlling force at work in crystallisation, that a *purely* geometrical theory of the formation of crystals which would make "facility of fitting-in" of the molecular particles its chief tenet, obviously does not tell us the complete story. Hence the author desires to utter a warning against going too far with the pure geometry of the subject. The geometricians have done a grand work in providing us with the thoroughly well-established 230 types of homogeneous structures, as a full and final explanation of the 32 classes of crystals, and so far their results are wholly and unreservedly acceptable, and are confirmed by the results of X-ray analysis.

It would appear as if the element sulphur is truly polymorphous in the sense which has now been explained. For the monoclinic prismatic form (Fig. 2, Plate I)—the best known and most easily prepared, from the state of fusion, of all the forms other than the common rhombic form, shown in Fig. 104, Plate XIX, in which sulphur is found in the neighbourhood of volcanoes and in which it is also deposited from solution in carbon bisulphide—is of distinctly lower stability, the crystals passing in a few days into powder composed of minute crystals of the stable rhombic variety. But the case of carbon is different, with its totally different and apparently at ordinary temperatures equally stable varieties of octahedral-cubic diamond (Fig. 125, Plate XXII) and hexagonal graphite, the structures of which as revealed by X-rays have been so fully discussed in Chapter XII; for although the diamond is converted into graphite at a red heat in the electric arc, it is highly probable that we are in the presence of a case of chemical polymerism or allotropy, like the case of ozone, where three atoms of oxygen compose the molecule, instead of the two atoms in the molecule of ordinary oxygen. The fact that the negatively electrified electronic corpuscles or electrons of the Crookes tube cause the same conversion of diamond into graphite, producing according to Parsons and Swinton a temperature of 4890° C. in the act, is evidence in favour of allotropy, as the charged corpuscles are a very likely agent for breaking down such atomic combinations. Moreover, diamond is volatilised out of contact with air at 3600° C. without liquefaction, and the vapour when cold condenses as

graphite. But there is reason to believe, from experiments by Sir Andrew Noble and Sir William Crookes, that under great pressure carbon does liquefy at 3600° C., and that the liquid drops on cooling crystallise as diamond. In any case it has been shown, on page 145, that the diamond form of carbon corresponds to the inorganic compounds of carbon and to the fatty series of organic compounds, while the graphitic form is present in the aromatic compounds.

The yellow and red varieties of phosphorus may also be due to a similar cause, the yellow variety, which forms excellent crystals, corresponding to P_4 , while the red variety may correspond to a molecule composed of a different number of atoms than four.

Indeed, a very large proportion of cases at first considered to be those of polymorphism have eventually turned out to be cases of (a) polymerism, or (b) isomerism; that is, (a) in which the constitutional formula is a multiple of the simplest (empirical) formula, special cases of which are those of the allotropic elements, or (b) in which the different varieties of similar empirical composition are of quite different chemical constitution. Physical chemistry has recently afforded some excellent methods of distinguishing between such cases and those of true polymorphism, with the result that but comparatively few truly polymorphous substances have been substantiated.

An amplification of the foregoing explanation of polymorphism has been brought forward by Lehmann, as the result of his remarkable experimental discovery of "liquid crystals," to which fuller reference will be made in Chapter XVIII, indicating the possible mode in which the stereometric position of the atoms in the molecule does actually influence and even determine the particular homogeneous structure which shall be erected, and explains why the temperature plays such an important rôle. Lehmann's theory is that any one definitely stereometrically constituted chemical molecule can only display one particular homogeneous structure and form of crystal, and that when at a particular temperature the system or class of symmetry is altered, this occurs because the stereometric arrangement of the atoms within the molecule is altered, that is, a new form of molecule is produced, which naturally gives rise to a new form of crystal. As far as the author understands it, this does not mean an isomeric change from the chemical point of view, the chemical compound remaining the same, but that the stereometric positions of the atoms have been changed, without altering their chemical attachments, but sufficiently to change the nature of the point-system which they produce. A significant fact in support of this view is that the molecules of the substances forming "liquid crystals" are usually very complicated and extended ones, com-

prising a large number of atoms, the molecules, in fact, corresponding in length with the long names of the organic substances of which they are generally composed.

Lehmann's work has certainly proved that the molecule is endowed with more individuality than has hitherto been ascribed to it, and he even shows that there is some ground for believing that his "liquid crystals" are such because this directive orientative force resident in the molecules themselves maintains them in their mutually orientated positions even in the liquid state, which may be and sometimes is as mobile as water. Recent work has tended to show, however, that the term "liquid crystal" is somewhat of a misnomer, and that these remarkable bodies are of an intermediate character between true solid crystals and true liquids, bodies in which, however, the identity of the molecule is very clear. Lehmann's researches in any case only tend to amplify and further explain the nature of polymorphism on the lines here laid down, the temperature of conversion of one form into another being merely that at which either a different homogeneous packing is possible, or that at which the stereometric relations of the atoms in the molecule are so altered as to produce a new form of point-system without forming a new chemical compound.

The main fact to emphasise is that polymorphism is due to the ability of the molecules of the substances displaying it to form two or more different space-lattices, within the temperature limits of ordinary observation. The different polymorphous states of the same substance only differ in their crystal structure and the properties dependent on that structure. On fusion, solution, or evaporation they all liberate identically similar chemical molecules.

CHAPTER XIV

ENANTIOMORPHISM OF CRYSTALLINE FORM AND OPTICAL ACTIVITY

It has already been stated that two supplementary forms which are similar but not identical, the one being the inverse or mirror-image reflection of the other, as a right-hand glove is to a left-hand one, are termed "enantiomorphous." Also it has been shown that all those crystal forms which have no plane of symmetry, either of simple symmetry or alternating symmetry (which is equivalent to saying that no centre of symmetry is present in addition to no plane of symmetry), are enantiomorphous, and that such forms belong to eleven specific classes. It has further been shown that the introduction of this principle of mirror-image symmetry or enantiomorphism into the conditions already laid down by Bravais and Sohncke for a homogeneous structure, by Fedorov, Schoenflies, and Barlow, enabled those investigators to derive the remaining 165 of the 230 possible types of homogeneous structures compatible with crystal structure, over and above the 65 already established by Bravais and Sohncke, and thus to complete the geometry of crystal structure, when the units of such structure are represented by points. Sohncke subsequently accepted the new principle, and modified his own theory so as to bring it into line with it. He exhibited some disinclination, however, at first, to accept the idea—which is a part of the assumption of the other three authors just referred to, and which appears to be absolutely necessary to explain one or two of the most complicated of the crystal classes—of the possibility of two enantiomorphous kinds of molecule being present in the crystal of the same single substance, the balancing of the two sets having the effect of producing mirror-image symmetry of the whole crystal, that is, the development of a plane of symmetry.

Now the whole subject is of deep interest, both physical and chemical as well as crystallographical, inasmuch as it is precisely such substances as show enantiomorphism—and can thus exist in two forms, one of which is the mirror-image of the other and not its identical counterpart, the two being like a pair of gloves—which are found to possess the property of rotating the plane of polarised

light and which are therefore said to be "optically active." Moreover, the property may be displayed by both the crystals and their respective solutions, or by the crystals only. If, therefore, two solid crystallised optical antipodes of the same substance are known, one rotating the plane of polarisation to the right and the other rotating it to the same extent to the left, their crystals invariably exhibit mirror-image symmetry with respect to each other. The converse does not necessarily hold good, however, that a crystal possessing the symmetry of one of these eleven classes will always exhibit optical activity.

Pasteur¹ was the first to recognise this important relation between enantiomorphous crystalline form and optical activity, in the case of tartaric acid, which has the empirical formula $C_4H_6O_6$ and the constitution :

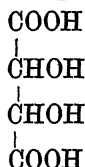

Tartaric acid was isolated by Scheele in 1769, and its discovery was described in the very first memoir of that distinguished chemist. Another very similar acid, as regards some of its more apparent properties, was afterwards, in 1819, described by John of Berlin, and investigated by Gay-Lussac in 1826; the latter obtained it from the grape-juice deposits of the wine manufactory of Kestner at Thann in the Vosges. It was still more fully investigated by Gmelin in 1829, who called it racemic acid (Traubensäure). But it needed the genius of Berzelius to prove that it really had the same composition as tartaric acid, although so different to that acid in some of its properties.

We have here, as a matter of fact, the first instance brought to light involving the principle of isomerism, the existence of two or more distinct compounds having the same chemical composition as regards the numbers of atoms of the same elements present, but differing in chemical or physical properties, or both, owing to the different arrangement of those atoms within the molecule. The "isomers" may be chemical or purely physical; the latter involves no alteration of the linking of the atoms, but merely of their disposition in space, and is the kind met with in the case of the tartaric acids.

Biot, so noted for his optical researches, showed afterwards that tartaric and racemic acids behave optically differently in solution,

¹ *Ann. de Chim. et Phys.*, 1848, **24**, 28 and 38; also 1850, **28**, 56; *Comptes Rendus*, 1848, **26**, 535; also 1849, **29**, 297; also 1850, **31**, 480; also 1853, **37**, 162, and 1858, **46**, 615.

an aqueous solution of the former rotating the plane of polarisation to the right whilst that of racemic acid is optically inactive, not rotating the plane of polarisation at all. That is, if the dark field be produced in the polariscope, by crossing the polarising and analysing Nicol prisms at right angles, tartaric acid solution will restore the light again, and the analyser will have to be rotated to the right (as the observer stands looking down the polariscope) in order to reproduce darkness. In the case of tartaric acid, the crystals themselves also rotate the plane of polarisation, the amount being as much as $11^{\circ}4$ in sodium light for a plate of the crystal one millimetre thick. On the other hand, neither the solution nor the crystals of racemic acid rotate the plane of polarisation at all.

Pasteur's discovery, made in the year 1848, consisted in finding that racemic acid is really a molecular compound of two physical "isomers," namely, of ordinary tartaric acid, which, as we have seen, rotates the plane of polarisation to the right, and of another variety of tartaric acid which rotates the beam of polarised light to the same extent to the left. The latter and ordinary tartaric acid he therefore distinguished as *lævo*-tartaric acid and *dextro*-tartaric acid respectively. Pasteur went even further than this, in discovering yet a fourth variety of tartaric acid, which is optically inactive like racemic acid, but which cannot be split up into two optically active antipodes.

Indeed, it has since been shown that there are three varieties of this truly inactive tartaric acid; they are cases of isomerism of the chemical molecule itself, that is, the stereometric arrangement of the atoms in the molecule is different in the three cases. For the molecule of tartaric acid—in common with the molecules of the vast majority of carbon compounds¹ the solutions of which, or which themselves in the liquid state, rotate the plane of polarisation—possesses an asymmetric carbon atom, an atom of carbon which is linked by its four valency attachments to four different kinds of atoms or radicle groups; indeed, the molecule of tartaric acid contains two such asymmetric carbon atoms, namely, the two in the pair of CHOH groups. For each of these carbon atoms is linked by one attachment to the carbon atom of the outer COOH group, by another to an atom of hydrogen, by a third to the oxygen of the group OH, and by its fourth attachment to the carbon atom of the other group CHOH, which carries the rest of the molecule, that is, this attachment is to the other half-molecule CHOH-COOH. Hence, it is quite obvious that there can be two different dispositions

¹ It will be shown later (page 163) that the presence of an asymmetric atom of carbon is not imperatively essential for optical activity, and that the only really valid condition for the display of optical rotation is the absence of a plane of symmetry.

of the atoms in space, one of which would be the mirror-image of the other, while leaving the arrangement of the atoms about the two asymmetric carbon atoms dissimilar and not symmetrical in mirror-image fashion. That is, the two dispositions would render the molecules in the two cases enantiomorphous with respect to each other, and these two would be the arrangements respectively in the two optically active varieties. That this is the correct explanation of the ordinary dextro variety and the lævo variety of tartaric acid can now admit of no doubt.

But if the groups round the two asymmetric carbon atoms are symmetrical in mirror-image fashion, there will be compensation within the molecule itself, and the substance will be optically inactive from internal reasons. This is the explanation of the optically inactive variety which is unresolvable into any components. The different varieties of this inactive form are doubtless due to the different possibilities of arrangement of the atoms in each half, while leaving the two halves round each asymmetric carbon atom symmetrical to each other.

We now know that the decomposable inactive variety, racemic acid, may be readily obtained by dissolving equal weights of the ordinary dextro and lævo varieties in water and crystallising the solution by slow evaporation at the ordinary temperature. For further investigation has fully borne out the conclusion of Pasteur that racemic acid simply consists of a molecular compound of the two active varieties. It is thus itself inactive because it is externally compensated, the two kinds of enantiomorphous molecules being alternately regularly distributed throughout the whole crystal structure, the very case which Fedorov, Schoenflies, and Barlow assumed to be possible, and which Sohncke only tardily admitted. The crystalline form of racemic acid is, as was to be expected, quite different from the monoclinic form of the active tartaric acids, being triclinic; and, indeed, it is not crystallographically comparable with the active form, inasmuch as the crystals of racemic acid contain a molecule of water of crystallisation, whereas the active varieties crystallise anhydrous. By crystallising at 73° C. however, Scacchi, in 1869, obtained anhydrous crystals of racemic acid, $C_4H_6O_6$, which also belong to class 2 (pinakoidal) of the triclinic system.

Ordinary dextro and lævo-tartaric acids crystallise in identical forms of the sphenoidal or monoclinic-hemimorphic class 4 of the monoclinic system, the class which is only symmetrical about a digonal axis, the unique symmetry plane of the monoclinic system, which also operates when full monoclinic symmetry is developed, being absent in this class. Hence the interfacial crystal angles, the monoclinic axial angle, and the axial ratios are identical

for the two varieties. But the crystals are hemimorphic, owing to the absence of the symmetry plane, and complementarily so, the dextro variety being distinguished by the presence of only the right clino-prism $\{011\}$, while the lævo variety is characterised by the presence only of the left clino-prism $\{0\bar{1}1\}$, these two complementary forms, each composed of only two faces and which on a holohedral crystal exhibiting the full symmetry of the monoclinic system would both be present as a single form of four faces, being never both developed on the same optically active crystal.

This hemimorphism of the two kinds of crystals will be rendered clear by Figs. 105 and 106, representing typical crystals of dextro and lævo-tartaric acids which are obviously the mirror-images of each other.

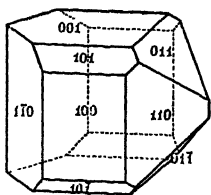

FIG. 105.

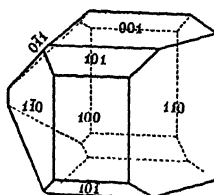
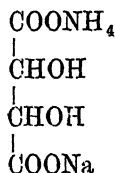

FIG. 106.

Crystals of Dextro and Lævo-Tartaric Acids.

A remarkable discovery was made by Pasteur in connection with one of the salts of racemic acid, sodium ammonium racemate, $\text{Na}(\text{NH}_4)\text{C}_4\text{H}_4\text{O}_6$, or



which is obtained by adding ammonia to the readily procurable salt hydrogen sodium racemate. Sodium ammonium racemate was found by Pasteur to be decomposable into the salts of dextro and lævo tartaric acids, on crystallisation of a solution saturated at 28°C . by inoculation with a crystal of either of those active salts. The solution on cooling being in the state of slight supersaturation, which we now know from the work of Ostwald and of Miers as the metastable condition, corresponding to the interval between the solubility and super-solubility curves (see Fig. 47, page 44), if a crystal, say, of sodium ammonium lævo-tartrate be introduced, this variety crystallises out first and can be separated from the residual dextro-salt, which can then be subsequently crystallised. Moreover, in certain direct crystallisations of sodium ammonium

racemate without such specialised inoculation, Pasteur found all the crystals hemimorphic, some right-handed and some left-handed, and he was actually able to isolate from each other crystals of the two varieties. On separate recrystallisation of these two sets of crystals, he found them to retain permanently their right- or left-handed character, indicating that the molecules themselves composing these crystals were enantiomorphous. Their solutions correspondingly rotated the plane of polarisation of light in opposite directions. Pasteur afterwards obtained from the dextro-salt pure ordinary (dextro) tartaric acid, and from the lævo-salt the lævo-acid, by converting them first into the lead salts and then precipitating the lead as sulphide by sulphuretted hydrogen.

In the case of lævo-tartaric acid, this was its first isolation, as it had hitherto been unknown. Gernez afterwards independently found that a saturated solution of sodium ammonium racemate affords crystals of the lævo-salt just as readily as of the dextro-salt; if a crystal of either salt be introduced, crystals corresponding to that variety are produced.

Another most fruitful observation of Pasteur, the principle of which has since been the means of isolating one of the two constituents of many racemic compounds, was that when the spores of *Penicillium glaucum* are added to a solution of racemic acid containing traces of phosphates the ordinary dextro component is destroyed by the organism, while the lævo component is unattacked so long as any dextro remains; hence, if the fermentation operation be stopped in time the lævo-acid may be isolated and crystallised. Why a living organism thus eats up by preference one variety only, possessing a particular right- or left-handed screw structure, of a compound containing the same elementary constituents chemically united in the same manner, remains a most interesting biological mystery.

The crystals of both dextro and lævo-tartaric acids prove to be pyro-electric, that is, develop electric excitation when slightly heated. The end which exhibits the development of the clinodome develops positive electricity in each case, when the crystal is allowed to cool after warming, so that the two varieties are oppositely pyro-electric, just as they are oppositely optically active. The most convenient method of demonstrating the fact is to dust a little of Kundt's powder, a mixture of finely powdered red lead and sulphur, through a fine muslin sieve on to the crystal as it cools. The sulphur becomes negatively electrified and the red lead positively by mutual friction of the particles in the sifting, and the sulphur thus attaches itself to the positively electrified part of the crystal and the red lead to the negatively electrified end. This phenomenon of the development by the two varieties of an optically active sub-

stance of opposite electrical polarity has since been shown to be a general one for all such cases of opposite optical rotation, characterised by polar symmetry, due to the possession of an axis of symmetry without a plane of symmetry perpendicular to it.

Finally, on mixing concentrated solutions containing equivalent weights of dextro and lævo-tartaric acid Pasteur observed that heat was evolved, a sign of chemical combination, and the solution afterwards deposited on cooling crystals of racemic acid. Hence, the only conclusion possible is that racemic acid must be a molecular compound of the two oppositely optically active tartaric acids. It thus partakes of the character of a double salt, analogous to potassium magnesium sulphate for instance. Consequently the crystal structure is one in which alternating molecules of the two acids are uniformly distributed, and the case is actually presented of two oppositely enantiomorphous sets of molecules producing a homogeneous structure. How completely this has all been confirmed by the X-ray analysis of tartaric and racemic acids has been made clear in Chapter XII, pages 135-139.

This interesting pioneer case of tartaric acid has been the cause of the term "racemic" being applied to the inactive form of a substance when it is decomposable into two oppositely optically active enantiomorphous varieties of the substance. No well-authenticated exception has been found, in all the many instances which have been observed of the phenomenon since Pasteur's time, to the fact that optically active substances exhibit what was formerly termed hemihedrism; that is, expressing the case in accordance with our later more accurate ideas of crystal structure as elucidated in previous chapters, such substances invariably belong to classes of symmetry possessing less than the full number of elements of symmetry possible to the system to which the class belongs. These classes are eleven in number, those possessing no plane of symmetry; they are, namely, the asymmetric class of the triclinic system, the sphenoidal class of the monoclinic system (to which the two tartaric acids, dextro and lævo, belong), the bisphe-noidal class of the rhombic system, the pyramidal and trapezohedral classes of the trigonal, tetragonal, and hexagonal systems, and the tetrahedral-pentagonal-dodecahedral and pentagonal-icositetra-hedral classes of the cubic system (see Appendix II).

The optical activity has been proved by Le Bel and Van t'Hoff to be due in most cases to enantiomorphism of the chemical molecules, that is, to the enantiomorphous stereometric arrangement of the atoms in the molecules, and therefore also,—as we have just seen, in accordance with the geometrical theory of crystal structure,—of the combined point-system in the case of each of the two varieties.

The point-systems are probably of a spiral screw-like character,

either right-handed or left-handed, as has been shown by Sohncke to be the case for the two varieties of quartz, which crystallises in the trapezohedral class of the trigonal system, one of the eleven classes just enumerated. The example afforded by quartz will be developed fully in the next two chapters, as this beautifully crystallised mineral enables us to study and to demonstrate the phenomena of optical activity in a unique manner and on the large scale.

The solutions as well as the crystals are usually optically active in the cases where, as in the instance of the tartaric acids, the substances are soluble in water or other solvent. Occasionally, however, the optical activity is lost by dissolving in a solvent, and in such cases it is the point-system only, and not the molecules themselves, which is enantiomorphous. Sodium chlorate, NaClO_3 , is an instance of this kind. Moreover, a crystal can belong, as already mentioned, to one of the eleven above enumerated classes of symmetry without displaying optical activity, as all the point-systems possessing the symmetry of these eleven classes do not exhibit screw-coincidence movements. Barium nitrate $\text{Ba}(\text{NO}_3)_2$ is such a case.

The two "optical antipodes," as the dextro and lævo varieties are conveniently termed, of an optically active substance thus possess an enantiomorphous crystal structure; but they are alike in their physical properties such as density, melting point, optical refraction and optic axial angle, cleavage, and elasticity. The crystal angles are identical for the forms which are developed in common by them, and which are usually those which the particular low class of symmetry possesses in common with the holohedral class of the system. The crystallographic difference between the two varieties comes in with respect to the specific forms characteristic of the particular class of lower than full systematic symmetry, and these forms are never displayed in common by the two varieties, this being the essence of the enantiomorphism. When the crystals are not rich in faces, however, it frequently happens that only the common forms of higher symmetry just referred to are developed on the crystals, and the two varieties are then indistinguishable in exterior configuration; it is only on testing their rotatory power, either by means of a section-plate of the crystal or by means of a solution, or their pyro-electric properties, or, lastly, their etch-figures afforded by a trace of a solvent (which etchings on the crystal faces are enantiomorphous and an excellent indication of the true symmetry), that their real character can be ascertained. Many mistakes have been made in the past, and crystals assigned to a higher than their true class of symmetry, owing to the investigation of only a single crop of crystals fortuitously poor in the number of forms displayed.

In the racemic form, if one should be deposited from the mixed solutions of the two optical antipodes as a molecular compound of the latter, we have an occurrence akin to polymerism, that is, the combination into a single whole entity of a number of molecules, essentially two in the case of racemism. Just as polymeric varieties of organic substances are always found to have quite different crystalline forms, so an optically inactive racemic form of a substance is generally quite different crystallographically to the dextro and lævo varieties. But there is occasionally some similarity along specific zones of the crystals, a kind of isogonism or morphotropy being developed, such as has been shown to occur, for instance, by Armstrong and Pope in the case of the substance *sobrerol*.¹

Besides the true racemic form it is often observed that under certain conditions crystals are obtained which appear to combine the characters of both the dextro and lævo varieties, exhibiting both series of distinguishing hemimorphic or hemihedral forms on the same crystal; that is, they show the full, holohedral, symmetry of the system. This has been shown by Kipping and Pope² to be due to repeated twinning, equally thin layers of the right- and left-handed varieties being alternated, just, in fact, as in the interesting form of quartz known as *amethyst*, to which reference with experimental demonstration will be made in Chapter XVII; the whole structure assumes in consequence the simulated higher symmetry which usually accompanies laminated twinning. Such forms have been termed "pseudo-racemic." In their memoir (*loc. cit.*, p. 993). Kipping and Pope summarise a large amount of highly interesting work on this chemico-crystallographic subject which has been carried out by them, and it may be useful to quote their precise definition of the relationship between racemic and pseudo-racemic substances. They say:

"We define a pseudo-racemic substance as an intercalation of an equal, or approximately equal, proportion of two enantiomorphously related components, each of which preserves its characteristic type of crystalline structure, but is so intercalated with the other as to form a crystalline individual of non-homogeneous structure. A solid racemic compound, on the other hand, may be defined as a crystalline substance of homogeneous structure which contains an equal proportion of two enantiomorphously related isomerides.

"The relations holding between a mere mixture of optical antipodes, a pseudo-racemic substance, and a racemic compound, are closely parallel to those existing between a crystalline mixture, an isomorphous mixture, and a double salt. The crystallographic methods, by which a double salt can be distinguished from an

¹ *Journ. Chem. Soc.*, 1891, 315.

² *Ibid.*, 1897, 989.

isomorphous mixture, may be directly applied to distinguish between racemic and pseudo-racemic substances. Thus, according as the crystalline substance obtained from a mixture of two salts resembles or differs from either of its components crystallographically, it is regarded either as an isomorphous mixture or a double salt; similarly, an inactive externally compensated substance, which closely resembles its active isomerides crystallographically, is to be considered as pseudo-racemic, whereas when the contrary is true, it is to be regarded as racemic."

The work of Kipping and Pope may be regarded as having finally vindicated and substantiated the law of Pasteur, that substances of enantiomorphous molecular configuration develop enantiomorphous crystalline structures, and that the crystal structures assumed by enantiomorphously related molecular configurations are themselves enantiomorphously related.

The Essential Condition for Optical Activity.—More recent research on this subject has shown that, although an asymmetric atom of carbon or other plurivalent element (of valency generally greater than three) is generally present in compounds exhibiting optical activity, this is not in itself the vital condition for the display of the property of rotation of the plane of polarisation of light. Indeed, several optically active substances have been brought to light by further investigation which contain no asymmetric plurivalent atom, and yet exhibit optical activity in two enantiomorphously related isomerides, optical antipodes, by virtue of the absence of symmetry elements of the second order, that is, of planes of symmetry or second order axes, and the presence of first order symmetry elements only, namely, rotation axes of symmetry. It has, in fact, been proved that this latter is the true condition for the development of optical activity, that the stereometric arrangement of the atoms in the molecule of the substance shall possess only symmetry properties of the first order, that is axial symmetry only, and that of the first order, such as the presence of rotation and screw axes, of the type present in the 65 regular point-systems of Sohncke; no second order symmetry element must be developed, such as one or more planes of symmetry, a centre of symmetry involving inversion about the centre, or axes of symmetry of the second order, such as those involving rotatory reflection.

As regards plurivalent elements other than carbon, the presence of an asymmetric pentavalent nitrogen atom has been shown by Kipping and others to lead to the development of optical activity in two optical antipodes. A similar result has also been proved by Pope, Kipping, and others, to occur for compounds containing an asymmetric tetravalent sulphur atom, or an analogous asymmetric selenium atom, or an asymmetric atom of tin. Similarly,

Meisenheimer and Lichtenberg, as well as Kipping, have demonstrated that an asymmetric pentavalent atom of phosphorus also gives rise to the possibility of the existence of two optical antipodes.

Werner and also Jaeger have further shown that certain complex compounds of some trivalent metals, namely, iron, cobalt, chromium, and rhodium, of the type $M'''X_3''R_3'$ —where M''' is the trivalent metal, X'' is a divalent radicle of an organic acid or base, and R' is a univalent halogen or alkali metal—also exhibit two separable enantiomorphous varieties of crystals, which possess relatively very large optical rotatory power. In all these cases, however, it is the absence of second order symmetry elements in the molecule, and the presence of only first order symmetry axes, which is invariably the one really essential condition, which determines that these substances shall exhibit optical activity in two enantiomorphous optical antipodes.

This subject, the main results and principles of which have now been elucidated, may well be closed with a reference to a case of enantiomorphism and optical activity which the author has himself investigated,¹ and which is very similar to the case of the tartaric acids. Incidentally, it will afford the opportunity of illustrating the mode of presenting the results of a crystallographic investigation, which was referred to on page 60. The investigation was suggested by the interesting observation of Prof. P. F. Frankland and Mr. W. Frew,² that when calcium glycerate was submitted to the fermenting action of the *Bacillus ethaceticus* one-half only of the glyceric acid was destroyed, and that the remaining half was optically active, rotating the plane of polarisation to the right.

Now glyceric acid, $\begin{array}{c} \text{CH}_2\text{-OH} \\ | \\ \text{CH-OH} \\ | \\ \text{COOH} \end{array}$, has manifestly one so-called asymmetric carbon atom (that is, a carbon atom the four valencies of which are satisfied by attachment to four different monad

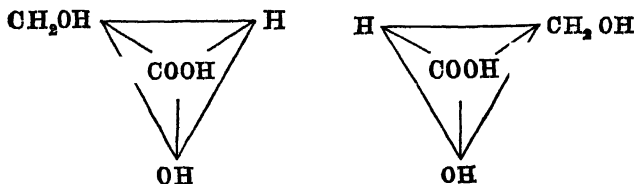

elements or groups), that belonging to the CHOH group. There are consequently two possible arrangements of the molecule in space, probably corresponding to the two optically active varieties,

¹ *Journ. Chem. Soc.*, 1891, 59, 233.

² *Ibid.*, 1891, 59, 96.

namely, those represented, as far as is possible in one plane, on page 164, the asymmetric carbon atom (not shown in the graphic representation) being supposed to be at the centre of the tetrahedron, which is usually taken to represent a carbon atom with its four valencies.

Dextro-glyceric acid itself proved to be an uncrystallisable syrup, but the calcium salt, $\text{Ca}(\text{C}_3\text{H}_5\text{O}_4)_2 \cdot 2\text{H}_2\text{O}$, was obtained in crystals sufficiently well formed to permit of a complete crystallographic investigation, which the author undertook by friendly arrangement with Prof. Frankland. Although the acid itself is dextro-rotatory, aqueous solutions of the calcium salt are lævo-rotatory to the extent of -12.09 units of "specific rotation" for sodium light.

The crystals were colourless well-formed prisms which proved to be of monoclinic symmetry, the best individuals being formed by very slow evaporation of the aqueous solution. They were terminated at both ends by pyramid and dome faces, and sometimes grew to the length of a centimetre. The actual crystal elements found after a full series of measurements, as described in Chapter VII, were as under :—

CALCIUM DEXTRO-GLYCERATE

Crystal-system : monoclinic.

Class of Monoclinic System : sphenoidal or monoclinic-hemimorphic.

Habit : prismatic.

Monoclinic axial angle : $\beta = 69^\circ 6'$.

Ratio of axes : $a : b : c = 1.4469 : 1 : 0.6694$.

Forms observed :

$$a = \{100\}, c = \{001\}, r' = \{\bar{2}01\}, p = \{110\},$$

$$m = \{011\}, o = \{111\}, s = \{\bar{1}\bar{1}1\}, n = \{\bar{2}\bar{1}1\}.$$

It will thus be seen that the system and the class are precisely those of the two active tartaric acids, which renders the case the more interesting. The usual appearance of the crystals is shown in Fig. 107, and the stereographic projection is given in Fig. 108, which will elucidate the symmetry more clearly, the plane of projection being the plane of symmetry. The latter, however, in this class is inoperative, the two ends of the digonal symmetry axis, which runs perpendicularly to the plane of the paper, being differently terminated, as in the tartaric acids. The faces of the forms $o = \{111\}$ and $m = \{011\}$ were never found developed on the left side of the symmetry plane, that is, on the left side of the crystal as drawn in Fig. 107, the symmetry plane running perpendicularly to the paper vertically from front to back ; they were only present

on the right. Conversely, the faces of $s = \{\bar{1}\bar{1}1\}$ and $n = \{\bar{2}\bar{1}1\}$ were never found developed on the right, but only on the left of the plane of possible symmetry.

Moreover, it was frequently observed that the right-hand faces (110) and ($\bar{1}\bar{1}0$) of the primary prism-form p were much more brilliant and truly plane than those on the left hand, ($1\bar{1}0$) and ($\bar{1}\bar{1}0$), which were usually dull and often curved, as were also frequently the faces of the left-hand forms s and n . The right-hand distinguishing forms m and o , on the contrary, were generally most brilliant and gave admirable reflections of the goniometer signal-slit. These observations are precisely such as might be expected from a crystal belonging to the hemimorphic class of the monoclinic system, the faces to the right and left of the possible symmetry plane now belonging to separate forms, owing to the absence of the plane of symmetry.

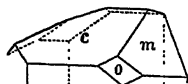

FIG. 107.—Crystal of Calcium Dextro-Glycerate.

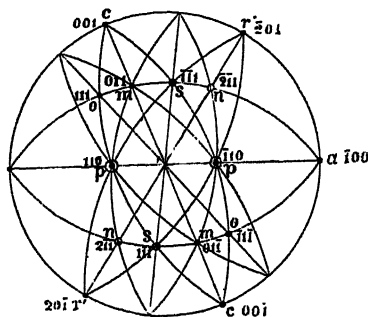

FIG. 108.—Stereographic Projection of Calcium Dextro-Glycerate.

The following table represents the results of the angular measurements, as recorded in the conventional manner, twelve different well-formed individual crystals having been employed. The angles marked with an asterisk were the important angles the mean observed values of which were accepted as correct, being the best measured angles, and which were therefore used as the basis of the calculations for all the other angles; some of these latter were not so accurately determinable, owing to dullness of one or both of the faces concerned, and the difference between the mean observed and the calculated values in these cases is therefore somewhat more than the three or four minutes permissible when the faces are good.

The crystals exhibited a moderately good cleavage parallel to the basal plane $c = \{001\}$.

The optical properties afford conclusive proof of the monoclinic nature of the symmetry. Although the mode of investigating the optical properties of crystals has not yet been fully described, but

will be dealt with in the next chapter, it will be convenient here to complete the description of the results of this investigation of calcium glycerate by a brief indication of the optical results, in order that it may be shown how they confirm the results of the goniometry. The plane of the optic axes is perpendicular to the possible symmetry plane, $b=\{010\}$, and the first median line

Table of Interfacial Angles of Calcium Glycerate.

Angle measured.	No. of measurements.	Limits.	Mean observed.	Calculated.	Difference.
$\left\{ \begin{array}{l} ap = 100 : 110 \\ pp = 110 : \bar{1}10 \end{array} \right.$	42	52°32'—54°16'	53°29'	*	
	20	72 7—73 33	73 4	73° 2'	2'
$\left\{ \begin{array}{l} ac = 100 : 001 \\ cr' = 001 : \bar{2}01 \\ r'a = \bar{2}01 : 100 \end{array} \right.$	13	68 22—69 42	69 3	69 6	3
	13	52 4—52 31	52 13	*	
	13	58 35—58 46	58 41	*	
$cm = 001 : 011$	10	31 47—32 19	32 3	32 2	1
$r'n = \bar{2}01 : \bar{2}11$	2	29 43—29 48	29 45	29 47	2
$\left\{ \begin{array}{l} ao = 100 : 111 \\ om = 111 : 011 \\ ma = 011 : 100 \\ an = 100 : \bar{2}11 \\ ns = \bar{2}11 : 111 \\ sa = 111 : 100 \end{array} \right.$	7	53 59—54 10	54 3	53 54	9
	7	18 20—18 35	18 26	18 29	3
	13	107 22—108 24	107 41	107 37	4
	11	62 32—63 44	63 6	63 10	4
	1	—	21 35	21 27	8
$sa = 111 : 100$	3	94 49—95 34	95 18	95 23	5
$\left\{ \begin{array}{l} po = 110 : 111 \\ oc = 111 : 001 \\ cs = 001 : \bar{1}11 \\ sp = \bar{1}11 : \bar{1}10 \\ pc = \bar{1}10 : 001 \\ cp = 001 : 110 \end{array} \right.$	9	43 51—44 44	44 35	44 38	3
	9	32 56—33 15	33 7	33 7	0
	7	41 32—43 2	42 10	42 17	7
	7	59 15—60 54	59 59	59 58	1
	14	77 2—78 21	77 42	77 45	3
	16	101 39—103 36	102 16	102 15	1
$\left\{ \begin{array}{l} pm = 110 : 011 \\ mn = 011 : \bar{2}11 \\ np = \bar{2}11 : \bar{1}10 \end{array} \right.$	9	52 15—53 25	52 42	52 41	1
	5	79 5—79 26	79 15	79 12	3
	5	47 41—48 23	48 4	48 7	3
$\left\{ \begin{array}{l} pr' = 110 : \bar{2}01 \\ r'p = \bar{2}01 : \bar{1}10 \\ ps = \bar{1}10 : 111 \\ sr' = 111 : 201 \end{array} \right.$	14	106 35—108 42	108 5	108 1	4
	26	70 54—73 32	71 55	71 59	4
	5	66 42—67 17	67 4	67 5	1
	6	40 36—41 29	41 5	40 56	9
$pm = 110 : 011$	3	75 5—76 21	75 37	75 45	8

makes an angle of 23° with the vertical axis c , emerging consequently nearly normal to the basal plane $c=\{001\}$, so that a section-plate parallel to the c -faces, or a tabular crystal or cleavage plate parallel to c , shows the optic axial rings and brushes well. The values of the apparent optic axial angle in air, $2E$, and of the true optic axial angle within the crystal, $2V_a$, the latter measured

with the aid of a pair of accurately ground section-plates perpendicular to the first and second median lines and immersed in oil, are given in the next table.

	2E	2V _a
For lithium light	. 51° 35'	34° 56'
„ sodium „	. 52° 30'	35° 28'
„ thallium „	. 53° 50'	36° 16'

The intermediate refractive index β was found to be as under :—

For red lithium light	. . .	1.4496
„ yellow sodium „	. . .	1.4521
„ green thallium „	. . .	1.4545

The double refraction was also determined and found to be of positive sign.

The optical properties of calcium dextro-glycerate thus confirm absolutely the monoclinic nature of the symmetry, as regards the crystal system. And it was conclusively demonstrated by the goniometrical part of the investigation that the exterior symmetry was not such as agreed with holohedral monoclinic symmetry, but with that of the sphenoidal class, in which the only one of the two elements of monoclinic symmetry (the plane of symmetry and the digonal axis of symmetry) in operation is the digonal axis, thus leaving the two terminations of that axis, at opposite sides, right and left, of the possible symmetry plane, unsymmetrical. And this is precisely the symmetry which is characteristic of an enantiomorphous optically active substance.

Unfortunately, the corresponding lævo-salt was not obtained in measurable crystals, but there can be no doubt that whenever such are forthcoming they will display enantiomorphism in the precisely opposite and complementary sense, the facial forms characteristic in this dextro-salt of the right termination of the digonal axis being absent on that side of the systematic symmetry plane but developed on the left side instead, and *vice versa*, and that the two enantiomorphous forms will together make up the whole of the faces required by the full symmetry of the monoclinic system.

A concrete instance like this, worked out practically in the laboratory, brings home the precise nature of this interesting relationship, between crystallographic and molecular enantiomorphism on the one hand and optical activity on the other hand, in a particularly clear and forcible manner.

CHAPTER XV

EFFECT OF THE SYMMETRY OF CRYSTALS ON THE PASSAGE OF LIGHT THROUGH THEM. QUARTZ, CALCITE, AND GYPSUM AS EXAMPLES

THE action of transparent crystals on the rays of light which they transmit is a subject not only of the deepest interest, but also of the utmost importance. For it is immediately possible to detect a cubic crystal, and to discriminate between two groups, optically uniaxial and biaxial respectively, of the other six systems of symmetry, three systems going to each group, by this means alone. For a cubic crystal is singly refractive in all directions. A 60°-prism, for instance, cut from a cube of rock-salt, for the purpose of obtaining the refractive index of the mineral by the ordinary method of producing a spectrum and arranging it for minimum deviation of the refracted rays, affords but a single spectrum, or a single sharp image of the spectrometer slit when the latter is fed by pure monochromatic light instead of ordinary white light. This is true however the prism may have been cut, as regards its orientation with respect to the natural crystal faces.

But a 60°-prism cut from a crystal belonging to the optically biaxial group, composed of the rhombic, monoclinic, and triclinic systems of symmetry, will always afford two images of the slit (see Fig. 66 on page 102), or two spectra, corresponding to two indices of refraction; and, when the orientation of the prism is arranged so that the refracting angle is bisected by a principal plane of the ellipsoid which represents the optical properties, and the refracting edge is parallel to one of the principal axes of the optical ellipsoid, the prism, when arranged for minimum deviation of the light rays, will at once afford two of the three refractive indices, α , β , γ , corresponding to light vibrations along two of the three principal axial directions of the ellipsoid. The two indices which the prism affords will be (1) the one which corresponds to vibrations parallel to the refracting edge, and (2) that which corresponds to undulations perpendicular to the edge and to the direction of transmission of the light through the prism (the third axis of the ellipsoid). For the vibrations of the light in the two rays into which the beam is divided on entering the crystal are both perpendicular to the direction of transmission

and to each other; the two images or spectra produced (as in Fig. 66) owing to the double refraction, that is, owing to the different velocities of the two mutually rectangularly vibrating rays, thus correctly afford the means of determining two of the three principal (axial) refractive indices.

Gypsum, the monoclinic hydrated sulphate of lime, $\text{CaSO}_4 \cdot 2\text{H}_2\text{O}$, already referred to in connection with the Mitscherlich experiment in Chapter VIII, is an excellent substance to employ for the demonstration of this fact, by cutting and polishing a 60° -prism out of a clear transparent crystal of the mineral as above described; and if a Nicol prism be introduced in the path of the rays, one spectrum or monochromatic image will be extinguished when the Nicol is arranged at its 0° position, and the other when the Nicol is rotated 90° from this position. This proves that the two rays affording the two refractive indices are polarised in planes at right angles to each other, and, moreover, enables us to verify that the planes in which the vibrations of the two rays occur are actually parallel and perpendicular respectively to the refracting edge of the prism. For the two extinctions occur when the vibration plane of the Nicol is either vertical, parallel to the prism edge, or horizontal, perpendicular thereto, respectively. (See pages 176 and 184.)

If a second prism be cut complementarily to the first, that is, so that the refracting edge is parallel to the third axis of the ellipsoid (the direction of transmission through the first prism) and the bisecting plane again parallel to one of the three axial planes of the ellipsoid, such a prism will also yield two refracted images corresponding to two indices; one of them, that particular image the vibrations of which are parallel to the refracting edge, will correspond to that one of the three principal indices which was not given by the first prism, while the other one will afford a duplicate determination of one of the two indices afforded by the first prism. Hence, a couple of such axially orientated prisms of a rhombic, monoclinic, or triclinic crystal will enable us to determine all three refractive indices and one of them in duplicate, which latter fact will enable us to check the accuracy of our work.

If the 60° -prism be cut from a crystal of the uniaxial group, that is, from a hexagonal, tetragonal, or trigonal crystal—quartz or calcite being admirable examples of the latter and particularly suitable for demonstration purposes—it will generally afford two spectra in the same manner as a crystal of the three bi-refringent systems of lower symmetry. But there is one special mode of cutting which results in the prism exhibiting only a single spectrum, namely, when the hexagonal, tetragonal, or trigonal axis of symmetry, which is also the unique “optic axis” of the crystal along which there is no double refraction, is arranged to be perpendicular to the bisecting

plane of the 60° -prism. For then the light is transmitted along this unique axial direction when the prism is arranged for the minimum deviation of the refracted rays out of their original path, and as it may vibrate in any direction perpendicular thereto with equal velocity there is no separation into two rays, that is, no double refraction, and thus only a single spectrum is afforded by such a prism in white light, or a single image of the slit in monochromatic light, and this latter will at once yield the refractive index which is generally indicated conventionally by the letter ω , corresponding to light vibrations perpendicular to the axis.

Spectroscopists take advantage of this interesting fact, when they employ a train of quartz prisms so cut in order to explore the violet and ultra-violet region of the spectrum; for quartz transmits many of the ultra-violet rays which glass absorbs. Each prism gives only a single image like glass, whereas if it were otherwise cut it would give two spectra, which would so complicate matters as to render quartz useless for the purpose.

When the prism of quartz or calcite, or of any hexagonal, tetragonal, or trigonal substance, is cut so that the rays of light are transmitted through it perpendicularly to the axis, and so that the refracting edge is parallel to the axis, the light is broken up into two rays, one of which is composed of light vibrating parallel to the edge and therefore to the axis, and the other of light vibrating perpendicularly to the axis. Such a prism consequently affords the two principal extreme refractive indices of the crystal, ω and ϵ , the latter letter being always assigned to the refractive index of a uniaxial crystal corresponding to vibrations parallel to the axis.

A uniaxial crystal, one belonging to the hexagonal, tetragonal, or trigonal systems, has thus two principal refractive indices, ω and ϵ , while a biaxial crystal, one belonging to the rhombic, monoclinic, or triclinic systems of symmetry, has three, α , β , γ , corresponding to vibrations respectively parallel to the three rectangular axial directions of the optical ellipsoid, which are also the crystallographic axial directions in the case of a rhombic crystal. The index α is the minimum, and γ the maximum refractive index, the β index being intermediate; when the latter lies nearer to α in value, the crystal is said to be a positive one, but when nearer to γ the crystal is conventionally supposed to be negative. Similarly, when in a uniaxial crystal ϵ is the greater, as it is in the case of quartz, the crystal is termed positive, but if ω be the greater index, as happens in the case of calcite, then the crystal is by convention considered negative.

Just as in the case of gypsum, which is a positive biaxial crystal (the reason for the term biaxial will presently be more fully explained), when the two spectra afforded by a prism of calcite or

quartz cut to afford both ϵ and ω are examined in plane polarised light, by introducing a Nicol prism somewhere in the path of the light, the two images corresponding respectively to ϵ and ω will be found to be produced by light polarised in two planes at right angles to each other. For when the Nicol is at its 0° position one will be extinguished, and when it is at 90° the other will be quenched. At the 45° position of the Nicol both images will be visible with their partial intensities, as happens also in the cases of biaxial prisms.

This behaviour of 60° -prisms of crystals belonging to the seven

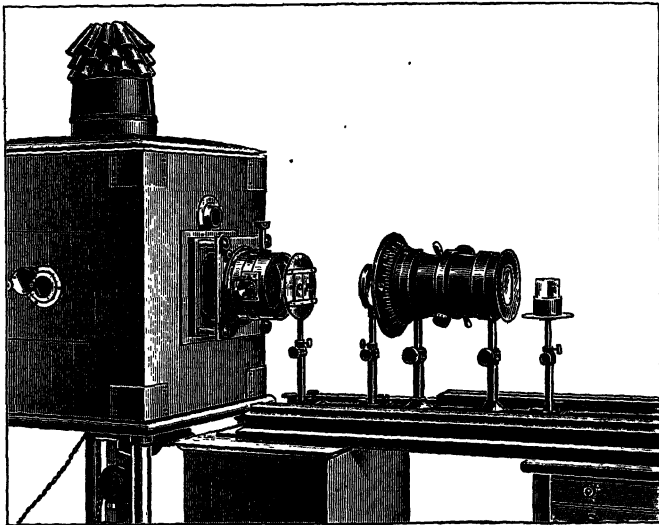

FIG. 109.—Experiment to show Rectangular Polarisation of the two Spectra afforded by a 60° -Prism of a Doubly Refracting Crystal cut to afford two Indices of Refraction.

different styles of crystal architecture, as compared with a prism of glass or other transparent non-crystalline substance, is extremely instructive. For not only is the optical constant refractive index—the measure of the power exhibited by the crystal of bending light, corresponding to its effect in retarding by the nature of its internal structure the velocity of the light vibrations—the most important of all the optical constants, but also in the course of its determination we learn more of the behaviour of crystals towards light than from any other type of optical experiment.

In Fig. 109 is shown a convenient mode of demonstrating the experiment with the aid of the electric lantern and one of the large Nicol prisms of the projection polariscope, already briefly described

in Chapter VIII in connection with the Mitscherlich experiment. The 60° -prism is arranged on a small adjustable stand nearest the screen ; then comes the Nicol polarising prism of $2\frac{1}{2}$ to 3 inches clear aperture, behind which is the projecting lens, at the focus of which is placed the adjustable slit on a separate stand. The slit is filled with light from the condenser of the electric lantern, and in the lantern front a thick water cell is arranged, in order to remove sufficient of the heat rays which accompany the light beam to avoid damage to the balsam joint of the calcite Nicol. When all the parts are properly arranged a sharp image of the slit should first be thrown on the screen directly, in the temporary absence of the 60° -prism, and then on replacing the latter at the proper angle for minimum deviation, when the light traverses the prism parallel to its third unused side, a spectrum or pair of spectra—according to the position of the Nicol and to the nature of the 60° -prism as explained in the foregoing discussion of the possibilities—will be projected on a second screen (or the same one if movable) arranged at the proper angle to receive the refracted rays.

If a single spectrum be afforded, which remains single on rotation of the Nicol, the prism is of glass or of a uniaxial crystal cut so that the light passes along the optic axis. If two spectra be shown when the Nicol is arranged in the neighbourhood of its 45° position, the crystal is a doubly refracting one, and if orientated so that the single optic axis, if the crystal be uniaxial, is parallel to the refracting edge, or, if the crystal be biaxial, so that the refracting edge is parallel to one of the three principal axes of the optical ellipsoid and its bisecting plane is parallel not only to this but also to a second principal axis, then one spectrum, corresponding to one principal refractive index, will extinguish when the Nicol is rotated to its 0° position, and the other spectrum, corresponding to a second principal refractive index, will be quenched on rotation of the Nicol to its 90° position.

The separation of the two spectra on the screen depends on the amount of the double refraction, and in the case of calcite this is exceptionally large, so that the two spectra are widely separated on the screen. They differ also considerably in dispersion. In the case of quartz the double refraction is very small, and the spectral images of the slit are consequently so close together as almost to touch one another. The pair of spectra afforded by gypsum are similarly very close together, owing also to weak double refraction. The amount of the double refraction is measured by the difference between the uniaxial indices ϵ and ω , or that between the minimum and maximum biaxial indices α and γ . The two spectra given by quartz and calcite will correspond to ϵ and ω , and the greatest separation of spectra occurs in the case of

gypsum when the spectra are those corresponding to α and γ , and not to α and β or β and γ .

It will now be useful and very helpful to examine more closely into the nature of the beautiful mineral quartz, in order that a series of interesting experiments may be described with it, which will assist largely in rendering the optical characters of crystals clear to us.

Quartz, rock crystal, although perhaps the commonest and best known of all crystallised substances, the naturally occurring dioxide of silicon SiO_2 , is yet one of the most remarkable and fascinatingly interesting. To begin with, as explained in the last chapter, quartz belongs to one of the eleven enantiomorphous classes of lower

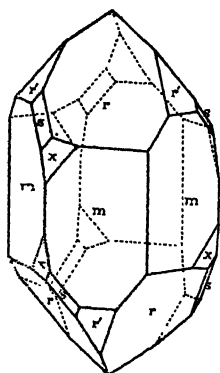

FIG. 110.

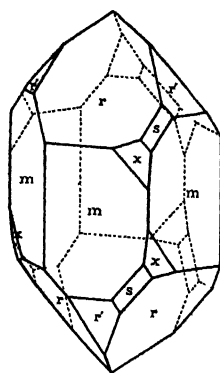

FIG. 111.

Left-handed and Right-handed Crystals of Quartz.

than full systematic symmetry, those which exhibit two mirror-image forms related to one another like a pair of gloves. The particular class of the eleven to which quartz belongs is the trapezohedral class of the trigonal system, and two typical left-handed and right-handed crystals are shown respectively in Fig. 110 and Fig. 111.

There is one principal form which is common to both the hexagonal and trigonal systems, namely, the hexagonal prism, and this is the chief form exhibited by quartz crystals. They are terminated by an apparently hexagonal pyramid, but which really consists of a pair of complementary rhombohedra, which are purely trigonal forms; three upper faces of each rhombohedron are developed at one end of the prism which may be regarded as the upper, and the three lower faces of each of the two individual rhombohedra likewise at the lower end of a fully developed doubly terminated crystal. The rhombohedron is the characteristic form of the trigonal system of crystal symmetry, the systematic crystallographic axes being parallel to its edges. It is like a cube deformed by extension or

compression along a diagonal, which latter is arranged vertically, and becomes the trigonal axis of symmetry (not a crystallographic axis), as shown in Fig. 112.

When two rhombohedra are equally developed, one being rotated with respect to the other 60° round the vertical trigonal axis of symmetry, they together resemble a hexagonal pyramid, and crystals of quartz thus terminated at both ends are not uncommon, so that at first sight a quartz crystal might be mistaken for a hexagonal prism doubly terminated by the hexagonal pyramid, and the mineral considered, in error, to belong to the hexagonal system.

But one alternate set of three faces of the hexagonal pyramid at one end, and the oppositely alternate set of three similar faces at the other end, will usually be found to be much less brilliant (indeed, often quite dull) than the other alternate three, and very frequently also the amount of development is markedly different, both facts indicating that the terminal faces belong to two different but complementary rhombohedral forms, and that the system of symmetry is the trigonal and not the hexagonal.

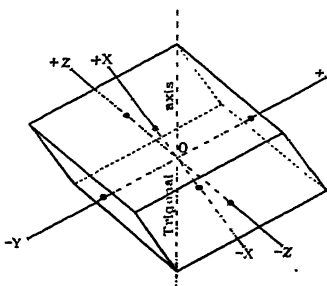

FIG. 112.—The Rhombohedron and its Axes.

But there is much stronger evidence than this for trigonal symmetry. For the little faces marked *s* and *x* on Figs. 110 and 111 are characteristic of the trapezohedral class of the trigonal system, and it will be observed that on the one crystal (Fig. 110) these faces occupy and modify a left-hand corner or solid angle on the crystal, while on the other crystal (Fig. 111) they occupy and replace a right-hand solid angle. Now, if a plate be cut out of the former crystal perpendicularly to the axis of the hexagonal prism, that is, to the optic axis of the trigonal uniaxial crystal, it will be found to rotate the plane of polarisation to the left, the direction in which the small faces are situated; while if a similar plate be cut out of the right-handed crystal shown in Fig. 111, that is, one which has the small faces on the right, it will be observed to rotate the plane of polarisation to the right.

As quartz possesses the symmetry of the trigonal system and is thus optically uniaxial, its optical properties are expressed, in common with those of all trigonal, tetragonal, and hexagonal crystals, by an ellipsoid of revolution, an ellipsoid the section of which perpendicular to the principal axis—that of revolution, the maximum or minimum diameter of the ellipsoid—is a circle. The optical properties are consequently the same in all directions

round this axis, which has already been referred to by its common appellation of the "optic axis."

The optic axis is identical in direction with the trigonal axis of symmetry in the case of quartz or other trigonal crystal, and in the cases of hexagonal and tetragonal crystals with the axes of hexagonal and tetragonal symmetry, these three axes of specific symmetry being the distinctive property of these three respective systems, which are thus known in common as optically "uniaxial."

Consequently, no double refraction is suffered by a ray transmitted parallel to the optic axis, and the refractive index is equal in all directions perpendicular to the optic axis, that is, for all rays transmitted along the axis and vibrating perpendicularly to the axis; hence the value of the refractive index obtained along any such direction is one extreme value for the whole crystal, and as already mentioned is distinguished by the letter ω . The refractive index along the direction of the axis itself is the other extreme value, and is labelled ϵ . It must be clearly appreciated, however, that it is not the direction of transmission but that of vibration perpendicular thereto, that is meant when it is said that, for instance, the direction of the axis corresponds to the index ϵ . That is to say, a ray the vibrations of which occur parallel to the optic axis of a uniaxial crystal is refracted to an amount which corresponds to the refractive index ϵ , while a ray the vibrations of which occur perpendicularly to the axis affords ω . The difference between ϵ and ω is the measure of the double refraction of the crystal.

In the case of quartz ϵ is the greater, being 1.5534 for sodium light, quartz being thus positive according to the convention already alluded to; while ω is the smaller, namely, 1.5443. In the case of the other widely distributed trigonally uniaxial mineral calcite, carbonate of lime CaCO_3 , the opposite is the case, ω being the greater, having the value 1.6583 for sodium light, and ϵ the less, namely, 1.4864, calcite being thus a negatively uniaxial substance. The amount of the double refraction in the cases of the two minerals is very different, $\epsilon - \omega$ for quartz being 0.0091, and $\omega - \epsilon$ for calcite being nineteen times as much, namely, 0.1719. Calcite is, indeed, a mineral endowed with an especially large amount of double refraction, a property which renders it so eminently suitable for use in demonstrating the phenomenon, and for the construction of the Nicol polarising prism, in which one of the two mutually perpendicularly polarised rays, that which affords the index ω , is got rid of by total reflection at a balsam joint, a large rhomb of calcite being cut in half along a particular diagonal plane and the two halves cemented together again with Canada balsam; the other ray which affords ϵ (but not at its minimum value), is transmitted as a beam of perfectly polarised light.

The result of this difference in the amount of the double refraction of the two minerals quartz and calcite is very interesting as regards their behaviour with polarised light. A thin plate of quartz, such as is often found in the slices of rock sections employed for microscopic investigation, of muscovite granite, quartz porphyry, or the graphic granite from Bodenmais, Bavaria, shown in Fig. 113, Plate XIX, facing page 150, for instance, and which is usually about one-fiftieth of a millimetre in thickness, shows brilliant colours in a parallel beam of polarised light, the Nicol prisms of the polarising microscope being crossed for the production of the dark field before the introduction of the section plate on the stage. The crystals of quartz are readily recognised in the slide of graphic granite reproduced photomicrographically in Fig. 113. For, owing to having been partially redissolved or eaten away by the surrounding matrix, at a time subsequent to their original crystallisation, they take the remarkable shapes shown in the illustration, which have been likened to the letters of oriental writing, hence the name "graphic" granite. Between crossed Nicols they stand out very clearly, owing to their brilliant polarisation colours compared with the rest of the field of matrix in which they are embedded. This brilliant polarisation of thin slices of quartz crystals only occurs, however, when the plate has not been cut perpendicularly to the axis, for such a thin plate thus cut does not perceptibly affect the dark field, there being no double refraction of rays transmitted along the axis, and the interference colours afforded by crystal plates in polarised light being due to the interference of the two rays produced by double refraction, one of which is retarded behind the other so as to be in a different phase of vibration. Also, the plate, even when cut obliquely, and best of all parallel, to the axis, has to be rotated in its own plane (perpendicular to the optical axis of the microscope), to the favourable position for the production of the most brilliant colour. This especially favourable position is half-way between (at 45° to) the positions at which darkness is afforded by the plate. For on rotating the plate between the crossed Nicols it becomes four times dark during a complete revolution, and at places exactly 90° apart, known as the "extinction positions," whenever, in fact, that plane perpendicular to the plate which contains the optic axis is parallel to the plane of polarisation of either the polarising or analysing Nicol. At the intermediate 45° positions the maximum colour is produced.

The colour owes its origin, as already mentioned, to the interference of the two rays, corresponding to the two refractive indices, into which the light is divided on entering the crystal in any direction except along the axis. For one of the rays is retarded behind the other owing to the difference in velocity which is expressed

reciprocally (inversely) by the refractive indices, and thus a difference of phase is produced between the two light-wave motions, with the inevitable result of interference when the vibrations have been reduced to the same plane by the analyser; light of one particular wave-length is then extinguished, and the plate therefore exhibits a tint in which the complementary colour to that extinguished predominates. The light which leaves the polarising Nicol is vibrating in one plane, but on reaching the crystal this is resolved into two rays vibrating at right angles to each other, and at 45° on each side of its previous direction of vibration, supposing the crystal to be arranged for the production of most brilliant colour. On reaching the analysing Nicol, the function of which is to bring the two vibrations again into the same plane, these two rays are each separately resolved back to the planes of vibration of the two Nicols, and that pair (one from each ray) vibrating parallel to the analysing Nicol are transmitted, while the other pair are extinguished. The two former rays thus surviving, one individual ray of the two having one refractive index and the other individual the other index, are thus in a position to interfere; for they are composed of vibrations in the same plane and of practically the same intensity, and differ only in phase. Extinction occurs when this amounts to half a wave-length, or an odd multiple of this, to which, however, requires to be added half a wave difference of phase which is introduced by the operation of the analyser. This explanation is a general one, applicable to thin plates of crystals belonging to all the six systems of symmetry other than the cubic. For plates of the latter, unless they are in an abnormal condition of strain, do not polarise.

When we take a plate of calcite of the same small thickness as that of the quartz in a rock section, thinner than a sheet of thin paper, we find that the calcite does not polarise. So great is the retardation of one of the two rays behind the other in calcite, that a plate excessively thin is required in order that colour shall be observed. For the colours of crystal plates under the polariscope, due to double refraction, are subject to the same laws as the colours of thin films, namely, that as the thickness increases—introducing more and more retardation in the case of a crystal, just as in a thin film greater length of path is introduced with increase of thickness—the various tints of all the seven orders of Newton's spectra are exhibited in turn, each spectrum differing by one further wave-length of retardation, and after the seventh the white of the higher orders (white light mixed with colour, the latter thus appearing only as a faint tint) gives place to true white light, colour being no longer perceptible. Hence with calcite, owing to the extremely powerful double refraction, and therefore very

considerable retardation of the slower ray behind the quicker, a plate a fiftieth of a millimetre only in thickness already shows the white of the higher orders, that is, appears only very feebly tinted with colour, and a plate of calcite very much thinner still is required to show brilliant colours. A plate of calcite, therefore, cut obliquely or parallel to the optic axis, of the thickness of a rock section or thicker, simply appears four times dark and four times light alternately, at positions 45° apart, as the section-plate is rotated in its own plane perpendicular to the axis of the polariscope.

When a plate of either quartz or calcite one-fiftieth of an inch thick, cut perpendicularly to the optic axis, is examined under the polariscope or polarising microscope, the dark field is unaffected by its introduction on the stage, remaining dark on a complete rotation of the crystal plate in its own plane. Moreover, the calcite plate continues to behave similarly however much the thickness is increased, the field remaining dark. But when quartz is examined as regards the effect of thickness an extraordinary thing happens. As the plate is thickened, that is, as a series of plates of gradually increasing thickness are successively placed on the stage, the dark field begins to brighten, and eventually colour makes its appearance. Moreover, rotation of the plate in its own plane—supposing the latter to be strictly perpendicular to the axis of the polariscope and the plate itself to have been truly cut perpendicularly to the optic axis of the quartz crystal—produces no change whatever, the colour remaining the same and evenly distributed over the plate, thus differing from the previous phenomena of interference due to double refraction. When monochromatic light is employed, yellow sodium light for instance, it is found that if the plate be not too thick, say a millimetre in thickness, the dark field is restored when the analyser is rotated in a particular direction, either to the right or to the left, for a specific angle, which is $21^\circ 42'$ for a plate of quartz one millimetre thick. Moreover, if the plate has been cut from a crystal showing the distinctive trapezohedral-class faces s and x on the right (Fig. 111) the analysing Nicol requires to be rotated to the right; whereas if the plate has been cut from a crystal showing these little determinative faces on the left (Fig. 110) the analyser has to be rotated to the left in order to quench the light.

It is obvious, therefore, that the colours of these thicker plates of quartz are due to the phenomenon of "optical activity," dealt with in the last chapter. The original plane of polarisation of the light received from the polarising Nicol is rotated by the quartz plate, and to an extent which is directly proportional to the thickness. When white light is used a particular colour is extinguished

for each position of the analyser, and the complementary colour therefore predominates in the tint actually exhibited. Now the most intensely luminous part of the spectrum is about wave-length 0.000550 millimetre in the yellow, and in the case of a plate of quartz 7.5 millimetres thick this colour is extinguished when the Nicols are crossed, while a plate of half this thickness, 3.75 mm., actually exhibits the colour under crossed Nicols and extinguishes it under parallel Nicols. For the angle of rotation of the plane of polarisation for light of this wave-length is 90° for a plate 3.75 mm. thick, so that the analyser has to be turned through a right angle from the crossed position, that is, placed parallel to the polariser, in order to extinguish this colour. A plate of double the thickness, 7.5 mm., will require the analyser to be rotated through 180° the angle of rotation for this thickness of plate, in order to extinguish this yellow ray. But 180° rotation simply brings the Nicol again to the crossed position, so that no rotation is really necessary at all.

Now the complementary colour to the yellow of wave-length 0.000550 mm. is the transition violet tint, the well-known "tint of passage" between the brilliant red end of the first order spectrum of Newton and the deep blue of the beginning of the second order. Hence, this violet tint is afforded by a plate of 7.5 mm. thickness when the Nicols are crossed, and by a plate of 3.75 mm. thickness when they are parallel. When, therefore, these plates are examined respectively under crossed and parallel Nicols, and the analysing Nicol is turned ever so little, the tint changes remarkably rapidly into brilliant red or blue, according to the direction of the rotation of the Nicol and the nature, whether right- or left-handed, of the quartz. Moreover, when two complementary plates of each thickness are thus examined, one of each pair being cut from a right-handed crystal and the other from a left-handed one, the colour will be red in one case and blue in the other for the same direction of rotation of the analyser.

The convention now universally employed, as regards the designation "right-handed" or "left-handed" optical rotation, is that initiated by Biot in 1813, when he first showed to the Institute of France that optically there were two kinds of quartz. Supposing that we are using a table polariscope, a plate from a crystallographically right-handed crystal, like that shown in Fig. 111, rotates the plane of polarisation to the right, as we are looking down the polariscope; and in white light, when we rotate the analyser from left to right, clockwise, it gives a sequence of colours which ascend in Newton's standard scale, that is, first red, then yellow, green, and blue. On the other hand, a plate from a left-handed crystal, such as that shown in Fig. 110, rotates the plane of polarisation to the left, and in white light requires the analyser to be rotated from right

to left, anti-clockwise, to give the standard ascending order of colours of Newton, red through yellow and green to blue.

A composite plate is frequently found very useful in work in connection with optical rotation, and is known as a "biquartz," two plates of opposite rotations being cemented together, edge to edge, by Canada balsam, the plane of junction (the two edge faces) being made perpendicular to the plate so as to be almost invisible when the plate is examined normally. When polarised light is employed, the least rotation of the analyser from exact crossing with the polariser, for which the violet transition tint is evenly produced over the whole composite plate, causes the half on one side of the plane of junction (appearing as a fine diametral line, assuming the field of the polariscope to be circular) to turn red and the other half to turn blue or green.

This, in essence, is the nature of the optical activity of quartz, and the secondary effects derived from it influence all the optical phenomena afforded by this interesting mineral. Owing to the fact that quartz crystals are practically unendowed with any facility for cleavage, the natural rhombohedral cleavage being very imperfectly developed and rarely seen, it is possible to cut, grind, and polish large plates of this beautiful, colourless, and limpidly transparent mineral without a trace of flaw (see also page 213). Such quartz plates of large size, adequate to fill the field of a large projection polariscope, the stage aperture of which is nearly 2 inches in diameter, form magnificent polarising objects for the projection on the screen of the effects observed in polarised light. As many of the optical properties of crystals may be illustrated with their aid, it is proposed in the next two chapters to describe a few of the more interesting screen experiments which can be performed with quartz, first (Chapter XVI) in convergent polarised light, and then (Chapter XVII) in parallel polarised light, and thus to illustrate the facts relating to the connection between optical activity and the internal structure of crystals in a manner which will at the same time be interesting and will lead to their much clearer comprehension.

The experiments described are largely those with which the author illustrated his lecture to the British Association for the Advancement of Science during their 1909 meeting at Winnipeg.

For the preparation of section-plates and 60°-prisms of crystals, accurately orientated with reference to the natural faces and the crystal axes, a cutting and grinding goniometer has been devised by the author and constructed by Messrs. Troughton and Simms. With its aid all the plates and prisms, involving over two thousand truly plane and correctly orientated surfaces, for the researches described in Chapter XI were prepared.

CHAPTER XVI

EXPERIMENTS WITH CRYSTALS IN CONVERGENT POLARISED LIGHT. QUARTZ, AS AN EXAMPLE OF MIRROR-IMAGE SYMMETRY AND ITS ACCOMPANYING OPTICAL ACTIVITY

It has already been shown that crystals are optically divisible into two classes characterised respectively by single and by double refraction. Singly refractive crystals belong exclusively to the system of highest symmetry, the cubic. They afford obviously only one index of refraction, which is generally symbolised by the Greek letter μ , the value of this constant being the same for all directions throughout the crystal. Crystals of the other six systems of symmetry are all doubly refractive. Those of the trigonal, tetragonal, and hexagonal systems have been shown in the last chapter to possess two refractive indices, a maximum and a minimum, one represented by ϵ corresponding to light vibrating parallel to the singular axis of the system, the trigonal, tetragonal, or hexagonal axis of symmetry, and another signified by ω corresponding to light vibrations perpendicular to that axis. For the properties are identical in all directions around this axis, which is thus the optic axis as well as the predominating crystallographic one. Such crystals are consequently known as "uniaxial." When ϵ is the larger refractive index the crystal is positive, while if ω be the maximum the crystal is said to be negative. It has been shown in the last chapter that quartz belongs to the positive category, while calcite is negative. Along the one direction of the optic axis these uniaxial crystals behave like singly refractive crystals do in all directions.

Crystals of the rhombic, monoclinic, and triclinic systems of symmetry have also a minimum refractive index, symbolised by α , and a maximum index indicated by γ , these two indices corresponding to light vibrating parallel to two directions at right angles to each other; the third direction perpendicular to both these and normal to their plane does not afford an index of refraction equal to either of these, however, as in the case of a uniaxial crystal, but one of an intermediate value, for which the second letter β of the Greek alphabet is reserved. Whether this value β is nearer

to the minimum α or to the maximum γ determines the conventional optical sign of the crystal, whether positive or negative. In the case of the rhombic system the three rectangular directions in question are identical with the three rectangular crystallographic axes. In the monoclinic system the single symmetry axis normal to the unique plane of symmetry is identical in direction with either the α , β , or γ optical direction, but in the triclinic system there are no coincidences between the crystal axes and those of the optical ellipsoid. Along none of these axial directions of the optical ellipsoid which can be imagined to express graphically the refractive index—an ellipsoid known as the optical “indicatrix,” and which has been shown by Fletcher to be a more convenient mode of expressing the optical characters of a crystal than the vibration-velocity ellipsoid of Fresnel—do the optical properties resemble those of a uniaxial crystal along the optic axis, or of a cubic singly refractive crystal, the crystal being doubly refractive along all three axes.

But it is a remarkable fact, nevertheless, that there are two directions in such a crystal along which the latter is apparently singly refractive, and these two directions are known as the “optic axes,” and the crystals of the three systems of lower symmetry are consequently said to be “biaxial.” These two singular directions are symmetrical to two of the three rectangular axes of the ellipsoid, those corresponding to the extreme indices α and γ , in the plane containing which two axes they lie, and they are perpendicular to the third β . For if we draw the ellipse of which the minimum and maximum axes are represented in length by α and γ , there will obviously be four symmetrical positions on the curve where a line drawn to the centre of the ellipse would be equal to the intermediate value β . If we join opposite pairs of these four points by diameters (lines passing through the centre of the ellipse) we have two directions each of which, together with the perpendicular direction of the β axis, lies on a circular section of the ellipsoid, for all radii from the centre lying in each of these sections are alike equal to β . Consequently, light transmitted along the two directions in the crystal normal (perpendicular) to these two circular sections will suffer no apparent double refraction, the refractive index being the same, namely, β , and the velocity of vibration equal in all directions in the crystal parallel to the two circular sections. Hence, we have two directions in biaxial crystals in which the optical properties are similar to those of uniaxial crystals along their singular optic axis. But the optical properties along the two optic axes of a biaxial crystal are advisedly stated to be “similar” to, and not “identical” with those along the optic axis of a uniaxial crystal; for although they

are identical to all ordinary experimental tests, they are not quite so when we come to ultimate details, which, however, are beyond the purview of this book, but an account of which will be found in the author's *Crystallography and Practical Crystal Measurement* (Macmillan and Co., second edition, 1922).

With these prefatory theoretical remarks, which are necessary in order that the experiments now to be described should be understood, we may proceed to consider a graduated series of experimental demonstrations which it is hoped will render clear some of the more important features of crystal structure which have been dealt with in previous chapters. Our principal agent will be polarised light, that is, light which has been reduced to vibration in a single plane by means of the well-known Nicol's prism. This latter is a rhomb of calcite which has been cut in two parts along a plane having a specific diagonal direction, and the two parts of which have been re-cemented together with Canada balsam. The result is that one of the two rays, known as the "ordinary" and which corresponds to the ω refractive index, into which the doubly refracting calcite crystal divides the ordinary light which it receives from the lantern or other source of light, is totally reflected at the layer of balsam, while the other ray, known as the "extraordinary" and corresponding to a refractive index of intermediate value between ω and ϵ , and composed of vibrations at right angles to those of the totally reflected ray, is alone transmitted, as a ray of plane polarised light.

We employ a pair of such Nicol prisms (a very valuable large pair being shown in Fig. 114), together with a convenient system of lenses for focussing either the object-crystal or the phenomena displayed by it; as a "polariscope," which is the most powerful weapon of optical research on crystals which has ever been invented. When the two prisms are arranged so that the vibration planes of the polarised light which they would singly transmit are parallel, we speak of them as "parallel Nicols," and light is transmitted unimpeded through the pair thus placed in succession; but when one of them is rotated the light diminishes, until when the vibration planes are at right angles no light escapes at all if the Nicols are properly constructed, there being produced what is known as the "dark field" of the "crossed Nicols." For the plane polarised light reaching the analyser from the polariser cannot get through the former, its plane of possible light vibration being perpendicular to that of the already polarised beam. As both Nicols are perfectly clear, colourless, and transparent, it is a never-ending source of amazement that the light should be absolutely shut off when the second prism is crossed to the first.

The phenomena exhibited by crystals in polarised light are of

two kinds, namely, those observed when a parallel (cylindrical) beam of light is passed through the crystal, and those exhibited when a converging (conical) beam of light is employed and concentrated on the crystal, the centre of which should occupy the apex of the cone. The disposition of apparatus in the former case of parallel light will be described in the next chapter and illustrated in Fig. 122. The arrangement for convergent light, as employed for projections on the screen, has already been referred to in connection with the Mitscherlich experiment with gypsum, and illustrated in Fig. 56 (page 74). The arrangement is shown again here for convenience, in Fig. 114. The parts of the apparatus are briefly as follows: (1) the electric lantern with self-adjusting Brockie-

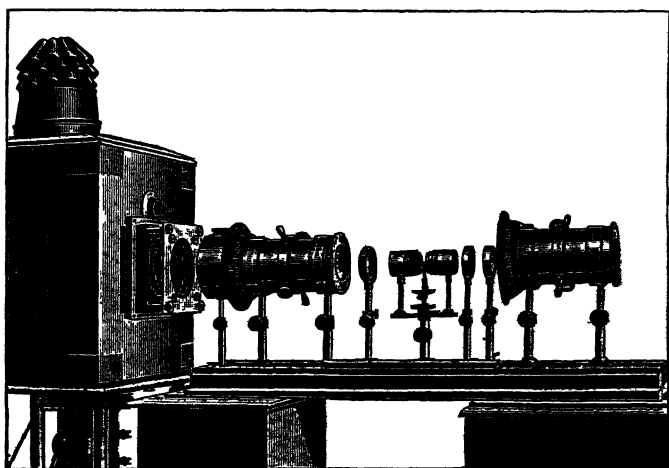

FIG. 114.—Projection Polariscope arranged for Convergent Light.

Pell or Oliver arc lamp and a $4\frac{1}{2}$ - or 5-inch set of condensers; (2) the water cell; (3) the polarising Nicol with a parallelising concave lens at its divided-circle end nearest the lantern; (4) a condensing lens; (5) the convergent system of three lenses closely mounted in succession; (6) the crystal; (7) the collecting system of three lenses equal and similar to the convergent system; (8) the field lens; (9) the projection lens; and (10) the analysing Nicol. The ten parts are separately mounted in the author's apparatus, which confers greater freedom in experimenting and more power of varying the conditions; the converging and collecting lens systems, however, are mounted in a separately adjustable manner on a common standard, which carries in the centre complete goniometrical adjustments for the crystal.

When we place on the stage of the polariscope (in the forceps

of the crystal holder in the arrangement shown in Fig. 114), the Nicols being crossed, a plate of a uniaxial crystal cut perpendicularly to the optic axis, and subsequently a similar plate of a biaxial crystal cut perpendicularly to that axis of the optical ellipsoid, either α or γ , which is the bisectrix of the acute angle between the two optic axes, and use the system of lenses which converges the light rays received from the polarising Nicol prism on the crystal, as shown in Fig. 114, we observe in the two cases quite different and very beautiful interference phenomena, which at once distinguish a uniaxial from a biaxial crystal. The two appearances are illustrated in Plate XX, by Figs. 115, 116, and 117, which are reproductions of the author's direct photographs. Fig. 115 shows the interference figure afforded by uniaxial calcite, which is the same for all positions of the crystal plate when rotated in its own plane by the rotation of the stage. Figs. 116 and 117 represent the interference figures given by biaxial aragonite, the orthorhombic form of carbonate of lime, calcite and aragonite being the two forms of this substance, which has been shown in Chapter VIII to be dimorphous. The effect shown in Fig. 116 is afforded when the line joining the two optic axes is parallel to the plane of vibration of either of the crossed Nicols, and the interference figure represented in Fig. 117 is given when the stage and crystal (or the two Nicols simultaneously) are rotated 45° .

The uniaxial calcite figure (Fig. 115) consists of circular spectrum-coloured rings resembling the well-known Newton's rings, but with a dark cross, fairly sharp near the centre but shading off towards the margin of the field, marking the directions of the vibration planes of the Nicols.

The biaxial aragonite figures (Figs. 116 and 117) show two series of rings surrounding the two optic axes and thus locating the positions of their emergence, equidistant from the centre of the field, where the bisectrix emerges. They are not circular, but are curves known as lemniscates, which are complete rings nearest to the two optic axes, but soon pass into figure-of-eight loops, and eventually into ellipse-like lemniscates enveloping both optic axes, and more and more approaching circles in their curvature as the margin of the field is approached. Moreover, when the direction of the line joining the two optic axes is parallel to the vibration plane of either of the Nicols, as was the case when Fig. 116 was produced and photographed, a black rectangular cross is seen, one bar, which is much the sharper one, passing through the optic axes and the other lying between them at right angles to the first bar, the centre of the cross being in the middle of the field.

On rotating the crystal plate in its own plane, while no change occurs with the calcite, the aragonite figure changes as regards the black cross, which breaks up into hyperbolic curves currently

FIG. 115.— Crystal Plate cut perpendicularly to the Axis

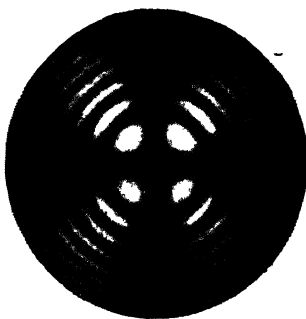

Uniaxial Interference Figure afforded by Calcite (Trigonal) in Convergent Polarised Light, with Crossed Nicols

FIG. 116.— Crystal Plate cut perpendicularly to the Bisectrix of the Acute Optic Axial Angle

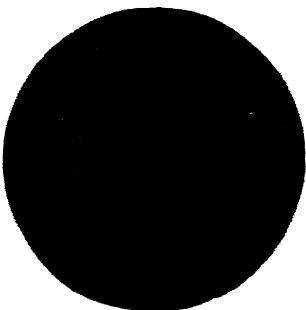

Biaxial Interference Figure afforded by Aragonite (Rhombic) in Convergent Polarised Light, with Nicols crossed and parallel to the Vibration Directions of the Crystal

FIG. 117.—The same Plate as for the previous Figure

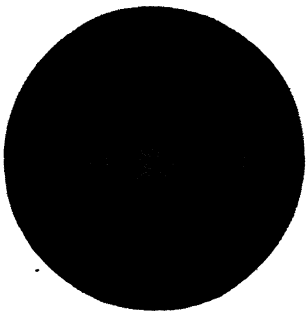

The same when the two Nicols have been rotated in the same direction for 45° , still remaining crossed

CHARACTERISTIC UNIAXIAL AND BIAxIAL INTERFERENCE FIGURES
IN CONVERGENT POLARISED LIGHT

(Reproductions of direct Photographs by the author.)

spoken of as "brushes," until when the plate has been rotated 45° the appearance is that shown in Fig. 117, the eye being supposed to have followed the rotation. Or, keeping the eye still, the effect shown in Fig. 117 is equally produced by the simultaneous rotation of both Nicols for 45° . The vertices of the hyperbolæ now mark the positions of the optic axes, and the angle between them is the apparent angle of the optic axes as seen in air, which is considerably different from the true angle between the optic axes within the crystal, owing to the very different refraction of light in air and in the crystal substance.

Now some crystals exhibit a very different optic axial angle at different temperatures, and one of the most beautiful experiments which have ever been performed is the Mitscherlich experiment with gypsum, which has already been described in Chapter VIII in connection with the work of Mitscherlich, and illustrated in Plate XIV, Figs. 57 to 60. Other substances, on the other hand, show a marked change of optic axial angle as the wave-length of the light is changed, and such a case has already been described in Chapter IX and illustrated in Plate XV, Fig. 63. The figure afforded by such a substance in ordinary white light is, however, a complicated one quite different from the normal one of Fig. 116, afforded by aragonite, as will be clear on reference to the interference figure shown at *f* in Fig. 63, which represents the figure given by ethyl triphenyl pyrrolone in white light.

In order to understand such biaxial interference figures thoroughly, they should be studied in monochromatic light, when one obtains a clear and sharp figure consisting of black curves as well as the cross or brushes, and very sharp vertices to the brushes when the crystal is arranged as in Fig. 117. The optic axial angle can then be measured for each important wave-length of light in turn, and the variation for wave-length followed throughout the whole spectrum. For this purpose it is very convenient to have a source of monochromatic light of any or every wave-length always at hand, and the author some years ago devised a spectroscopic monochromatic illuminator,¹ for use with any observing instrument, and which is particularly convenient for use with the polariscopical goniometer which is employed in practice for the measurement of optic axial angles, by bringing first one and then the other hyperbolic vertex to the cross wires by rotation of the crystal plate. It is shown, along with the latter instrument, in Fig. 118. The spectroscope has a single but very large prism of heavy but colourless flint glass, and the spectrum produced—the electric lantern being the source of light, its rays being concentrated on the slit—is filtered through a second slit at the other end of the

¹ *Phil. Trans. Roy. Soc.*, 1895, A, 185, 913.

spectroscope, where the detachable eye-piece is situated when the instrument is used as an ordinary spectroscope, and for the calibration (with the Fraunhofer solar lines) of the circle on which the prism is mounted. The escaping narrow slit of monochromatic light includes only the 250th part of the spectrum, so is monochromatic in a high sense of the word. It impinges on a little ground glass diffuser carried in a very short tube in front of this exit slit, and the optic axial angle polariscope is brought up almost into contact with the ground glass, and is thus supplied with an even field of pure monochromatic light. With this apparatus it is easy to observe the exact crossing wave-length in all cases of crossed-

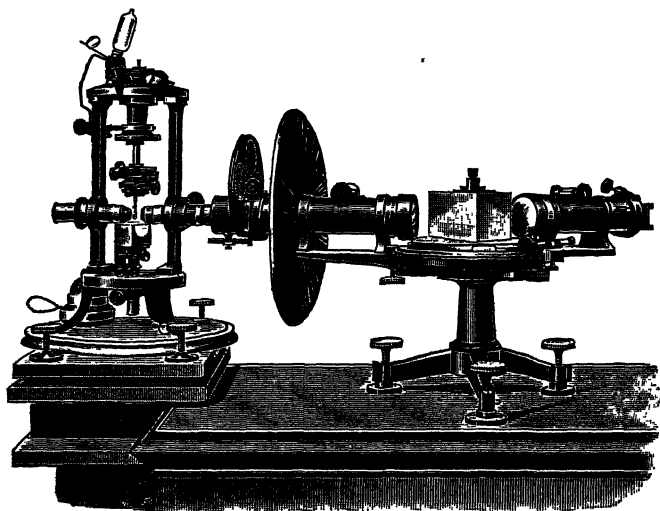
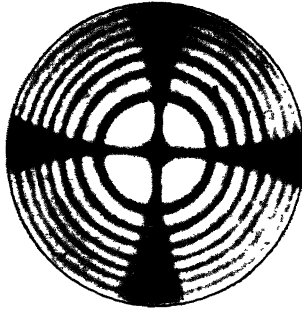

Fig. 118.—Optic Axial Angle Goniometer and Spectroscopic Monochromatic Illuminator.

axial-plane dispersion such as that illustrated in Fig. 63 ; for the reading of the graduated circle on which the prism is mounted, and which is rotated in order to cause monochromatic light of the different wave-lengths in turn to stream through the exit slit, affords the exact wave-length with the aid of the calibration curve once for all prepared. This calibration of the graduations is readily carried out by using sunlight, and determining the readings corresponding to the adjustment of the principal Fraunhofer lines in the middle of the exit slit.

Having thus rendered clear the nature of ordinary interference figures afforded by crystals of the two types, uniaxial and biaxial, in convergent polarised light, we may pass on to see what happens when we take a number of plates of quartz of different thicknesses,

FIG. 119



Interference Figure afforded by a Quartz Plate, 1 Millimetre thick, in strongly Convergent Polarised Light

FIG. 120

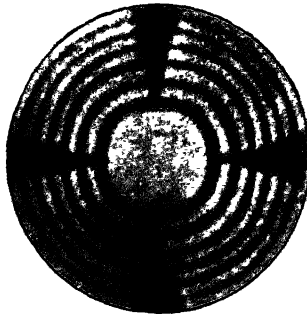

Interference Figure afforded by a Quartz Plate, 3.75 Millimetres thick, in moderately Convergent Polarised Light

FIG. 121

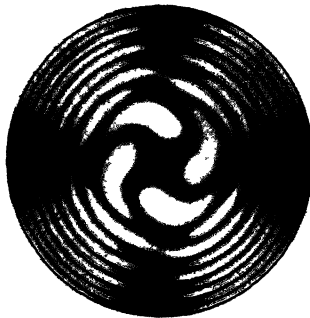

Interference Figure (Airy's Spirals) afforded by two superposed Quartz Plates, 3.75 Millimetres thick, one of Right-handed Quartz and the other of Left-handed Quartz, in moderately Convergent Polarised Light

INTERFERENCE FIGURES IN CONVERGENT POLARISED LIGHT AFFORDED BY QUARTZ PLATES CUT PERPENDICULARLY TO THE AXIS

cut perpendicularly to the optic axis in all cases, instead of a plate of calcite. We will examine first a fine pair of hexagonal quartz plates so cut, each 1 millimetre thick exactly, and about 2 inches in diameter. One was cut from a right-handed hexagonal prism, and the other from a similar left-handed one.

Employing the lantern projection polariscope shown in Fig. 114, arranged for convergent light just as for the Mitscherlich experiment, and with the Nicols crossed, we will now see what happens when each of these plates in turn is placed at the focus of the light rays, between the two convergent systems of lenses. On the screen we observe in each case a somewhat similar interference figure to that given by calcite, a black cross and rainbow-coloured circular rings, the smallest ring, however, being very large relatively to the innermost ring given by calcite, and the other rings being also further separated from each other. Moreover, the black cross appears broadened out, this spreading of both rings and cross being due to the thinness of the plate combined with the low double refraction of quartz. Further, the right-handed and left-handed plates both afford apparently identical figures. In order to obtain a sharp figure like that of calcite we require to add a fourth lens, kept in reserve for such cases, to each of the two similar convergent lens-systems, one on each side of the crystal-plate, in order to increase the convergence of the light rays. The figure then obtained with one of the two plates is reproduced in Fig. 119, Plate XXI.

Let us now observe, however, what occurs when a thicker plate of quartz is used. Taking one of 7.5 mm. thickness, and placing it in the focus of the converging rays, after removing the two extra lenses, we see on the screen quite a different effect, an attempt to reproduce which photographically in black and white (for another plate of 3.75 mm. thickness, the effect with which is very similar) is made in Fig. 120 on the same Plate XXI. The rings are closer together (using the same degree of convergence), and the innermost is smaller; moreover, within it all signs of the central part of the black cross have disappeared, and instead a brilliant violet colour is shown, which alters to bright red of the first order spectrum with the least rotation of the analysing Nicol in one direction from its crossed position with respect to the polarising Nicol, while if the rotation be in the opposite direction the deep blue of Newton's second order is produced. The arms of the cross, however, appear towards the margin of the field. The violet colour shown for the exact position of crossing of the Nicols is the tint of passage between the first and second orders of Newton's spectra, and this illumination of the central part of the interference figure is obviously the effect of the optical activity of quartz, for the tint is the same as is produced with the plate in ordinary parallel plane-polarised light,

and is, in fact, due to the central axial rays of the convergent cone being practically parallel.

On rotating the analysing Nicol for a few more degrees to the right we observe that the innermost ring widens out and that the red passes into orange and yellow, the quartz plate being a right-handed one. But when a similar plate cut from a left-handed quartz crystal is used instead, the inner ring closes up somewhat for the same rotation of the analyser, moving inwards instead of outwards, and the blue colour given with the first slight rotation passes into green and yellow as the rotation is continued. Moreover, the circular character of the rings is altered, and so much so that when the rotation has proceeded as far as 45° the shape of the rings has changed almost to a square. These alterations in the interference figure are characteristic of the two varieties of quartz crystals. A useful rule to remember is, that for a right-handed crystal rotation of the analyser to the right causes the colours to appear in the order of their refrangibility, namely, the least refrangible red first, then orange, yellow, green, blue and violet in their order; while for a left-handed crystal the converse is true when the direction of rotation of the analyser is the same, that is, to the right, clockwise; obviously also the colours appear in the opposite order when the rotation of the analyser is to the left.

It will now prove of interest to examine the effects produced by two plates of opposite varieties of quartz of half this thickness, namely, 3.75 mm. The phenomena are very similar to those just described (indeed the figure given in Fig. 120, Plate XXI, was actually observed with such a plate), but the rings are a little wider, and the larger area within the innermost ring is now filled with yellow light instead of violet, when the analyser is exactly crossed to the polariser. It passes into a bright green when the analyser is rotated slightly on one side, and into orange when the Nicol is rotated in the reverse direction. But the most interesting thing of all is to observe what occurs when these two plates of 3.75 mm. thickness, one of right-handed quartz and the other of left-handed, are superposed and placed in contact together as one plate, of double the thickness, 7.5 mm., at the convergent focus. A beautiful spiral figure is produced on the screen, composed of the celebrated "Airy's spirals" as if the black cross were being reproduced in the central part, but with each of its bars distorted into the shape of the inverted letter S, as shown in Fig. 121 at the foot of Plate XXI. The contrary effects of the two opposing rotations are thus extraordinarily indicated visually in the interference figure afforded by the composite plate.

Now, it is of great practical interest that certain quartz crystals are found in nature which show Airy's spirals directly, on cutting

a plate 7.5 mm. thick or thereabouts, perpendicular to the optic axis. For instance, one in the author's collection of quartzes, a single plate of an apparently homogeneous and perfectly limpid crystal, shows the spirals exceedingly well and clearly defined. As a matter of fact, it is a twin, a right and a left-handed crystal being twinned together with an invisible plane of composition, which is only revealed on examining the crystal in polarised light, as will be demonstrated in the next chapter by the use of parallel polarised light. The fact of such a plate of quartz affording Airy's spirals in convergent polarised light is, however, of itself an excellent proof of the twinning of two crystal individuals of the opposite varieties.

Now the very shape of these spiral figures suggests screw action of the molecular structure of the crystals on the waves of light passing through them, and moreover, of the action of two screws of opposite directions of winding, one clockwise and the other anti-clockwise, thus remarkably confirming the supposition, now proved to be a fact by X-ray analysis (page 126), that the point-systems of the structure of the right- and left-handed varieties of quartz are of a helical nature and respectively of opposite modes of winding.

Another experiment, devised by Reusch, which still further enhances the probability that this supposition as to the structure of quartz crystals is correct, may next be introduced. A thin film of biaxial mica has been cut into twenty-four narrow strips, which have been laid over each other at angles of 60° , so that a screw-shaped pile has been formed of the central overlapping parts, consisting of four complete rotations; that is, there are four repetitions of the "pitch" of the screw, each composed of six films. On placing this composite plate of mica at the convergent focus of the lantern polariscope, so that the overhanging ends of any four identically superposed strips occupy the focus, the ordinary biaxial interference figure of mica—two sets of rings and hyperbolic brushes, very much like Fig. 57, Plate XIV, is observed on the screen. But when the plate is moved so that the central part comes into the focus, where all the twenty-four films overlap in their six different orientations 60° apart, and so that all the light rays have to traverse the whole helical pile of the twenty-four films, a uniaxial figure exactly like that of quartz is produced, namely, one composed of circular rings, with a black cross only visible, however, at the marginal part, and with the inner ring filled with brightly coloured light. Moreover, on slightly rotating the analysing Nicol the innermost ring moves outwards or inwards and the colour changes to blue or red, according to the direction in which the helix had been wound, in exact accordance with the rule stated above for quartz.

If now a second such helical pile of mica films, but one for which the opposite manner of winding has been adopted, anti-clockwise if the first had been clockwise, be examined at the convergent focus, precisely the same appearance will be observed with crossed Nicols, but the opposite changes will occur on rotating the analyser. Finally, to complete the interesting proof of the helical nature of quartz crystals, when these two oppositely wound composite mica plates are superposed—each being marked carefully to indicate the direction of the helix and the proper mode of superposition in order to effect precise oppositeness of arrangement, mirror-image symmetry, in fact, about the plane of contact—and placed in the convergent beam near its focus, there is at once seen on the screen a magnificent display of Airy's spirals, as perfect as those afforded by the fine natural twin last experimented with. Hence, there can be no doubt whatever that the remarkable optical behaviour of quartz is due to its point-system being of a helical nature, a right or a left-handed screw structure being apparently produced in nature with equal facility. The circumstances of environment during the formation of the crystal probably determine which variety shall be produced, and when the nature of the environment becomes changed during the operation of formation either twins are produced of the two varieties, or separate individual crystals.

This may well conclude our experiments in convergent polarised light, which—including the beautiful Mitscherlich experiment described in Chapter VIII, of exhibiting the crossing of the optic axial plane in the case of gypsum; and the production of all the types of interference figures in succession, as the crystal becomes warmed by the heat rays accompanying the beam of convergent light—will have introduced the reader to a typical series of such experiments, and such as were actually exhibited by the author to the British Association at Winnipeg. We may pass, therefore, in the next chapter to the consideration of an equally interesting series in which a parallel beam of polarised light will be used, which will still further elucidate the internal structure in the especially instructive case of quartz crystals, and that of crystals in general.

CHAPTER XVII

EXPERIMENTS WITH QUARTZ AND GYPSUM IN PARALLEL POLARISED LIGHT. GENERAL CONCLUSIONS FROM THE EXPERIMENTS WITH QUARTZ.

IN order to rearrange the projection polariscope for experiments in parallel light, we simply remove the three lenses on separate stands (Fig. 114), and the convergent systems of lenses on their special adjustable stand with goniometrical crystal holder, from between the two Nicol prisms, and replace them by two other separately mounted lenses, acting together as an achromatic projecting objective, and a rotatable object stage. The whole arrangement as thus altered for experiments in parallel polarised light is shown in position in Fig. 122. The change is readily made, a gap in the plinth-bed guides near the analysing Nicol enabling it to be effected without removing either of the prisms, the analyser being simply drawn along a few inches nearer to the end in order to expose the changing gap. The pair of lenses consists of a plano-convex lens of 5 inches focus and $2\frac{1}{4}$ inches diameter, and another plano-convex lens of $8\frac{1}{2}$ inches focus and 2 inches aperture, with their convex faces turned towards each other. Together they produce on the screen an excellent image of the object on the stage, and the size of the image can be varied at will by regulating the relative positions of the two lenses with respect to each other and to the object stage. If found more suitable for the particular screen distance available, the 5-inch lens may be replaced by a 6-inch lens also provided as an alternative.

When the analysing Nicol is arranged with its vibration direction parallel to that of the polariser, we obtain bright light on the screen on actuating the electric lantern, and the image of an object on the stage can thus be projected on the screen on a bright ground. But when the analyser is crossed to the polariser, that is, rotated to the position 90° from this parallel position, the two planes of vibration of the Nicols being then at right angles, the screen is quite dark. Before continuing in this dark field our experimental study of quartz, which is obviously a type of the more exceptionally behaving substances owing to its special structure, it will be wise to examine a more ordinary kind of crystalline substance. For this

purpose gypsum—better known in optical work as selenite, hydrated sulphate of lime, $\text{CaSO}_4 \cdot 2\text{H}_2\text{O}$, crystallising in beautifully transparent and often large crystals belonging to the monoclinic system, a typical one of which has been illustrated in Fig. 9 (page 9), and which we have already referred to in connection with the Mitscherlich experiment described in Chapter VIII—is especially suitable, on account of its clear and colourless transparency, the large size of crystals available, and the brilliancy of the polarisation colours which they afford when adequately thin. A very perfect cleavage being developed parallel to the symmetry plane, the clinopinakoc

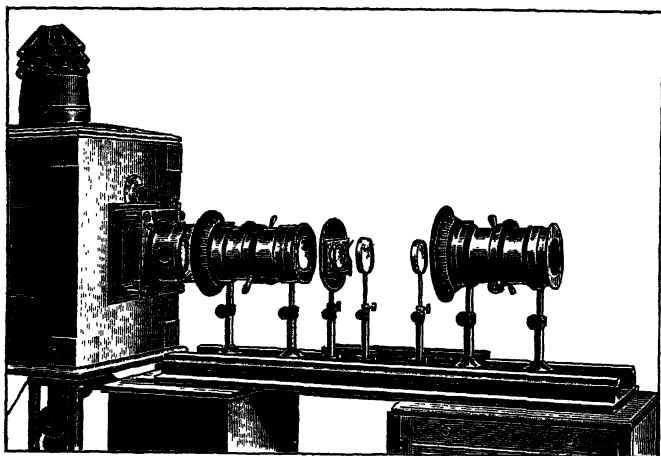

FIG. 122.—Projection Polariscope arranged for Parallel Light.

{010}, such thin films, of even thickness throughout, can be readily prepared.

Such a very thin cleavage plate, about $1\frac{1}{2}$ inches in its longest dimension, is mounted with Canada balsam between a pair of circular glass plates $1\frac{3}{8}$ inches in diameter, the standard size of object plates for the projection polariscope; the triple plate is then supported in a mahogany frame also of the standard size—4 by $2\frac{1}{4}$ inches, with clear aperture of $1\frac{5}{8}$ inches diameter and supporting a rabbet for the plate $1\frac{1}{8}$ to 2 inches diameter—on the rotating stage by a pair of spring clips. The Nicols being arranged with their vibration directions parallel, in order to permit light to travel to the screen, and the lenses being arranged properly for a sharp focussed picture of suitable size, the outline of the crystal plate will be seen on the screen, and the whole area of the crystal will either at once appear coloured, or will do so on more or less rotation of the stage carrying the crystal, which rotates the latter in it

own plane. The crystal outline is of the character shown in Fig. 123, which also gives the positions of the crystal axes a and c , and a simple stereographic projection of the faces of the crystal, from which the nature of the faces bounding the section-plate will be clear.

On rotating the Nicol analyser the colours change, and appear at their maximum brilliancy when the field is dark and the Nicols crossed. Leaving the analyser crossed to the polariser, and rotating the stage and therefore the crystal, the colours again change, and at certain positions 90° apart during the rotation, marked by the two strong lines in Fig. 123, they disappear altogether, and the crystal becomes dark like the rest of the field, while the positions of maximum brilliancy of colour are found to be situated at the 45° -positions intermediate between these positions of "extinction."

When the quenching occurs the vibration planes of the two rays, travelling by virtue of double refraction through the crystal, are parallel to the planes of vibration of the rays transmitted through the two Nicols, and the fact is a very important one, enabling us to determine the directions of light vibration in the crystal. In the case of our gypsum plate, the cleavage of gypsum being parallel to the unique plane of symmetry of the monoclinic crystal, these

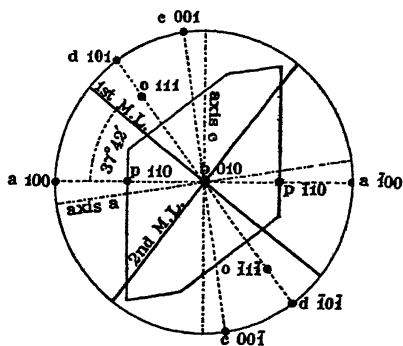

FIG. 123.—Section of Gypsum Crystal showing the Extinction Directions.

two positions are the directions of the two axes of the optical ellipsoid which lie in the symmetry plane, and they correspond to the vibration directions of rays affording the refractive indices α and γ . The direction corresponding to γ is that of the "first median line," the bisectrix of the acute angle between the optic axes; while α corresponds to the obtuse bisectrix or "second median line." These directions are clearly marked by the strong lines in Fig. 123. The third axis of the optical ellipsoid is obviously perpendicular to the plate and to the symmetry plane, and corresponds to the intermediate refractive index β . Thus this simple observation of the extinction directions in such a case as gypsum enables us at once to fix completely the orientation of the optical ellipsoid, a fundamental optical determination.

A second thin plate of gypsum may next be examined, similarly prepared and mounted. It is clearly a composite one, being composed of a pair of twins. For when placed on the stage in the dark

field of the crossed Nicols, and rotated to the position for maximum brilliancy of colour, it shows different colours in the two halves, as indicated by different shading in Fig. 124. If, however, the analysing Nicol prism be withdrawn from the plinth-bed and removed altogether the crystal appears in its natural colourless condition as a single one, with no indication whatever of any line of division.

Some exceedingly brilliant polarisation effects are afforded by a number of objects exhibited by the author in his lecture at Winnipeg,

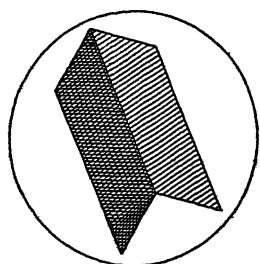

FIG. 124.—Twin of Gypsum as seen in Parallel Polarised Light.

composed of selenite (gypsum) twins and triplets, some arranged to cross one another like the mica films of Reusch described in the last chapter, but only for a single rotation, three twin strips going to a rotation, at angular distances of 120° ; others are arranged in geometrical patterns, and in circles overlapping one another, and the whole series afford the most gorgeous and variegated display of colour imaginable, the colours, moreover, altering either on rotation of the stage or of the analysing Nicol, and thus passing

through every tint conceivable.

Having thus demonstrated the usual effect afforded by a doubly refracting crystal plate in parallel polarised light, we may next illustrate two special cases, which will lead us up to the case of quartz once more. The first relates to a crystal belonging to the cubic system, which is theoretically singly refractive or "isotropic"; the second concerns a plate of a uniaxial crystal cut perpendicularly to the optic axis, the unique direction of single refraction of such a crystal. A plate of flint glass affords a good example of the first case. When placed on the stage of the polariscope it shows no colour at all in polarised light, whatever be the position of the two Nicols with respect to each other, and the field remains dark when they are crossed, the crystal, in fact, behaving just like so much glass.

A word of caution, however, is here necessary, for natural mineral crystals are not unfrequently formed under conditions of considerable strain, at high temperatures or under great pressure, as in the case of the diamond for instance. So that we must be careful to choose a normal and well-formed crystal of flint glass for our experiment. This point may be well illustrated by placing on the stage a thick circular plate of glass, an inch or more in diameter, which has been purposely heated and then suddenly cooled in order to evoke such a condition of strain. Crossing the

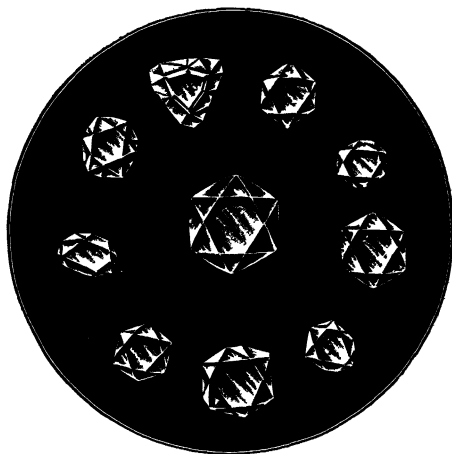

FIG. 125.—Ten Diamonds exhibiting Natural Faces, mounted for the Lantern Polariscope, to show Polarisation Colours due to Internal Strain

Nicols so as to obtain the dark field, there is at once produced on the screen a black cross and circular concentric spectrum-coloured rings, resembling with wonderful simulation the interference figure, shown in Fig. 115, Plate XX, afforded by calcite or other uniaxial crystal in convergent polarised light. Artificial double refraction has been produced in the glass by the strained conditions, in a fashion concentrically symmetrical to the axis of the cylinder, an interference figure being afforded symmetrical about the axis of the cylinder as if it were an optic axis.

The diamond crystallises in the cubic system, in octahedra, hexakis octahedra, or hexakis tetrahedra, and should, therefore, theoretically be without effect on polarised light. Yet it is rare to find a diamond which does not show more or less colour in the dark field, owing to the condition of strain in which it exists. It is notorious that the strain is occasionally so great that a diamond explodes into powder shortly after removal from its enveloping matrix of blue clay. The author, by the great kindness of the late Sir William Crookes, was enabled to show on the screen, both in a lecture at the Royal Society and in the Evening Discourse to the British Association at Winnipeg, the images of ten magnificent large diamonds,¹ natural, perfectly formed crystals uncut and unspoil by the lapidary. They were mounted between two circular glass plates of the usual $1\frac{7}{8}$ inches diameter, the diamonds being attached by balsam to one of them; each plate was held in a mahogany frame of $1\frac{5}{8}$ inches circular aperture, the two frames being then rigidly attached face to face to form a single one, an enclosing cell, which could be placed on the rotating stage as an object-slide for the projection polariscope. The appearance of the diamonds on the screen in ordinary light is reproduced in Fig. 125, Plate XXII, as well as is possible without their natural colour, for while several of them are brilliantly colourless, others are tinted, one being a bright green diamond. On producing the dark field by crossing the analysing Nicol with respect to the polariser, the darkness was dispelled by brilliant polarisation colours, at once revealing the diamonds and outlining them clearly against the dark background. On rotating the analyser the colours changed in the usual manner of polarising objects, and bright colours were shown by all the diamonds even when the Nicols were parallel.

It is obvious, then, that both a transparent non-crystalline substance such as glass, and a cubic crystal, must be free from strain in order that it shall exhibit no colour in polarised light and, indeed, no polarisation effects whatever, and behave as an isotropic substance.

¹ The diamonds are now in the Mineral Collection at the Natural History Museum (British Museum) at South Kensington.

The second special case to which attention may be called, that of a plate of an ordinary uniaxial crystal such as calcite, cut perpendicularly to the optic axis, is also obviously subject to the same proviso, that the crystal must be free from strain in order to exhibit the normal phenomena. Such a perfectly normal plate remains quite obscure in the dark field in parallel light, producing neither colour nor interference figure, even on rotation of the object stage with the crystal, in its own plane. For the light traverses the crystal along the optic axis, the axis of single refraction, and the vibrations occur with equal velocity in all directions perpendicular to it. Hence there is no division into two rays, one retarded behind the other on account of less velocity of vibration, and therefore no interference colour.

And now this leads us back to quartz, for this mineral is also uniaxial, and we will investigate in the same manner in parallel polarised light the plates of the mineral cut perpendicularly to the optic axis, which have already been referred to in connection with the experiments concerning the interference figures produced in convergent polarised light. Suppose we take first the large plate of quartz 7.5 mm. thick and over 2 inches in diameter. Placing it on the stage--instead of finding the dark field to be unaffected by the introduction of the plate, and to remain so on rotation of the latter in its own plane, as should theoretically be the case if quartz were a normal uniaxial crystal, and as indeed has been actually shown to be the case with calcite—we observe that it polarises in brilliant colour, the whole hexagonal outline of the plate, clearly focussed on the screen, being filled with an evenly brilliant violet tint, the tint of passage, just as the central part of the interference figure, within the innermost ring, had been coloured in the convergent light experiment with the same plate. The colour changes with the slightest rotation of either of the Nicols, passing into red for one direction of rotation and into blue and green when the Nicol is rotated in the other direction. The tint also alters when the section-plate is rotated about its vertical diameter, by rotating the upper adjustable part of the supporting column of the stage within its outer fixed tubular column; this latter change is equivalent to a thickening of the plate, the light beam having to traverse a longer path through the quartz during such oblique setting of the plate.

This colour is due to the same fact which produced colour in the central part of the interference figure, namely, the optical activity of quartz, the fact that the plane of vibration of a beam of plane-polarised light transmitted along the axis of quartz is rotated to the right hand or to the left. The amount of this rotation is precisely equal, although opposite in direction, for the two

varieties of quartz, but the rotation varies very considerably for different rays of the spectrum. It also varies directly proportionally to the thickness of the plate. A plate one millimetre thick cut perpendicularly to the axis rotates the plane of polarisation for red hydrogen light (C of the spectrum) to the extent of $17^{\circ} 19'$, for yellow D sodium light $21^{\circ} 42'$, and for greenish blue F hydrogen light $32^{\circ} 46'$. The rotation is a maximum for plates perpendicular to the axis, and the effect is inappreciable in directions at right angles thereto. It is clearly due to the oppositely spiral winding of the regular-point-system of the crystal structure of the two varieties, round the direction of the optic axis, the trigonal axis of symmetry of the crystal, a structure which we have proved to be characteristic of quartz by the beautiful experiments with the helical piles of mica plates, absolutely reproducing the polarisation effects with quartz, as described in the last chapter.

The opposite optical rotation of the two varieties of quartz can be well shown by constructing a "biquartz," as already mentioned on page 181. Two plates of equal thickness, preferably either 7.5 mm. or 3.75 mm., are cut, one from a right-handed and the other from a left-handed crystal, each exactly perpendicular to the optic axis. The two edge-surfaces to be subsequently joined together are also cut, ground and polished as true planes perpendicular to the plate surfaces, and the two plates are then cemented together with Canada balsam by these two prepared edge-surfaces, taking care that the broad plate-surfaces of the two halves are absolutely continuous as if the whole were a single parallel-surfaced plate of quartz. Such a composite plate or "biquartz" is one of the most useful aids to the study of optical activity, being much used for enhancing the sensitiveness of the determination of the angle of rotation.

When the image of such a 7.5 mm. biquartz, mounted in the usual mahogany frame and placed on the object stage of the projection polariscope, is thrown on the screen (see Fig. 129 on page 202)—the Nicols being crossed for production of the dark field, and the stage and crystal plate being strictly perpendicular to the parallel beam of polarised light—the whole of the screen covered by the image of the plate appears uniformly coloured with the violet tint of passage. But the moment the analysing Nicol is rotated for a very few degrees, one half turns red and the other blue and then green. If the Nicol be turned back again to the crossing position with the polariser, and then rotated further in the opposite direction to the former rotation, the appearances on the two sides of the sharply focussed fine line of demarcation between the two halves are inverted, the side which formerly turned red now becoming green, and *vice versa*. The two varieties of quartz are thus oppositely

affected, and it will be obvious that the biquartz is a very delicate test for the exact crossing of a pair of polarising prisms, and a very sensitive means of enhancing the determination of the position for the mutual extinction of two rectangularly polarised beams of light in general.

A very striking and beautiful mode of exhibiting this opposite and equal rotation of the plane of polarisation by the two varieties of quartz may next be described, an experiment which we owe to the late Prof. S. P. Thompson. A composite plate of mica is constructed out of 24 sectors of 15° angle each, the whole making up a complete circular plate. They are cemented between two circular glass plates of the usual $1\frac{1}{8}$ inch size, with balsam; the sectors are laid down in succession on one of the plates first, side by side, with the edge of every one in turn in close contact with the edge of the next in order, so as to radiate from a common centre.

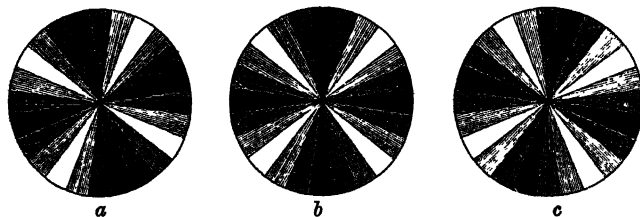

FIG. 126.—A disc *b* of 24 Mica Sectors under Crossed Nicols, showing Effects at *a* and *c* of Introduction of Left- and Right-handed Quartz Plates.

The second glass plate is only cemented after the arrangement has been allowed to set for some days, when there is less risk of disturbing the mounting of the sectors. The latter have all been cut from the same film of mica which has a thickness corresponding to a retardation of one of the two rays produced by the double refraction of the crystal behind the other equal to one and a half waves. Each sector is so cut that the line bisecting the 15° angle is parallel to the line joining the positions of emergence of the two optic axes of the crystal.

On placing this wheel of mica on the polariscope stage, the Nicols being crossed, the effect shown at *b* in Fig. 126 is observed on the screen. The four sectors 90° apart, the bisecting lines of which are vertical and horizontal respectively, parallel to the vibration planes of the Nicols, appear as a jet-black cross; the sectors next to them appear pale brown, and the next again a still paler delicate shade of sepia, while the central diagonal ones of each quadrant, at 45° to the black cross, are brilliantly white.

On now introducing behind or in front of the stage a right-handed quartz plate one millimetre thick, one of the pair of large ones

described in one of the convergent light experiments of the last chapter, the black cross is observed to be deflected one sector to the right, as shown at *c* in Fig. 126; whereas when the left-handed companion plate is introduced in like manner the cross moves over one sector to the left, as indicated at *a* in Fig. 126. The two quartz plates are mounted on the same mahogany object frame, a specially long one with two large apertures carrying the quartzes; and a special stage frame (not shown in Fig. 122) to take this object frame easily and loosely is fitted, when required, close behind the ordinary object stage shown in Fig. 122, so that first one quartz and then the other can be placed in or out of position, and when

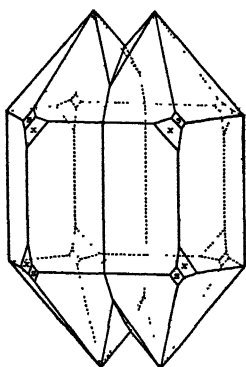

FIG. 127.—Pair of Brazilian Twins of Quartz.

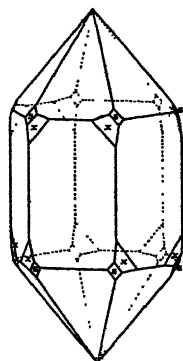

FIG. 128.—Completely Interpenetrated Brazilian Twins of Quartz.

this is done rapidly the movement of the cross from right to left and back again is very marked.

Occasionally a natural biquartz is obtained, on cutting a plate out of a crystal of quartz perpendicularly to the axis. For it is not uncommon to find a crystal which, while apparently a single crystal, is really a twin, the two right and left individuals being joined by an invisible plane of contact, or "plane of composition" as it is called, so beautifully have the two grown together. Figs. 127 and 128 show two kinds of twins of quartz. The former consists of two obviously different individuals, with the little *s* and *x* faces indicating right or left-handedness clearly developed in an opposite manner. The crystal shown in Fig. 128, however, appears to be a single individual, yet differs from either a right-handed or a left-handed crystal in showing the *s* and *x* faces developed on both right and left solid angles. It is a case of complete interpenetration.

In both cases the plane of twinning is parallel to the optic axis, and to a pair of faces of the hexagonal prism of the second order,

perpendicular to a pair of the actual first order prism faces shown by the crystal. They are examples of the well-known "Brazilian twinning" of quartz, so called because many quartz crystals found in Brazil display it.

A natural biquartz of 3.75 millimetres thickness cut from such a crystal as is shown in Fig. 128, the plate having a hexagonal outline just as if the crystal were really a single one, may next be projected on the screen. The Nicols being crossed, the outline of the crystal is seen sharply defined, the whole area of the crystal being coloured a uniform yellow, there being absolutely no trace of any dividing line. But the moment one commences to turn the analysing Nicol different shades, orange and green respectively, begin to develop on the two sides of the line indicating the plane of composition of the twin, the hexagon being divided by a diametral

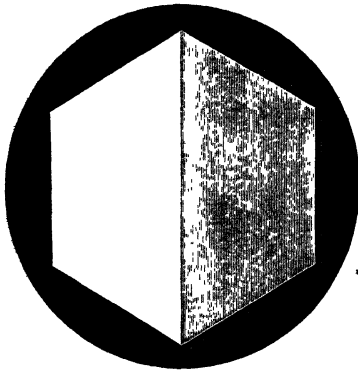

FIG. 129.—A Natural Biquartz in Parallel Polarised Light. Nicols not quite crossed.

line joining two corners, which have been arranged in mounting the plate in its carrier frame to be above one another, so as to bring the line of composition vertical, as will be clear from Fig. 129. On rotating the analyser further the difference is still more marked, and we have blue on one side and orange-red on the other, developing still deeper into red and purple as the analyser approaches the parallel position with respect to the polariser; when this latter position is attained the transition violet tint is developed evenly over the

whole plate, and the dividing line has again disappeared.

Another natural biquartz, also shown in the author's lecture at Winnipeg, introduces us to a new phenomenon. For when the Nicols are crossed we observe a black band down the centre of the plate, marking the line of division of the twins. When the analyser is rotated until it is parallel to the polariser this black band changes to a white one, the sequence of colours on the different sides of the band, that is, in each half of the plate, being the same as just described. The effect with crossed Nicols is more or less simulated in Fig. 130, Plate XXIII, which is a reproduction of a direct photograph of the screen picture. The reason for this black band in the dark field, and for the white one in the bright field, is that the two halves of the twin overlap at the centre, the plane of junction of the two individual crystals being oblique to the plate, instead

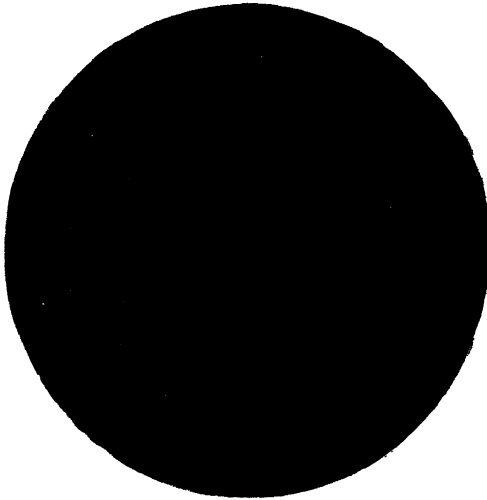

FIG. 130.—Natural Biquartz, 3.75 mm. thick, exhibiting the Black Band (Nicols crossed) at the Oblique Junction of the Right-handed and Left-handed Parts

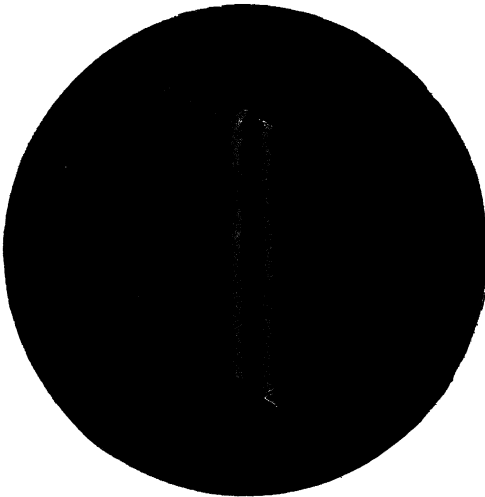

FIG. 131.—Artificial Biquartz, 7.5 mm. thick, the two parts being obliquely joined in order to produce the Black Band

DIRECT PHOTOGRAPHS OF PICTURES PROJECTED ON THE SCREEN BY THE LANTERN POLARISCOPE, USING PARALLEL LIGHT

of exactly perpendicular thereto as was the case with the first natural biquartz. We are, in fact, beginning to get the effect of two superposed wedges of quartz.

When the obliquity is greater, or the crystal thicker, a white band appears on each side of the black central one, the Nicols being crossed, and when the thickness is as great as 6 to 7.5 mm. a spectrum band appears on each side of the white one.

That this obliquity of the surface of contact of the two intergrown individuals (not the plane of twinning, which remains parallel to a pair of faces of the hexagonal prism of the second order) is the true explanation can be readily proved by reproducing the effect artificially. A thick double plate of quartz is constructed, as shown in Fig. 131, Plate XXIII, composed of two halves of respectively right-handed and left-handed quartz, each about 7 millimetres thick, and each of which has had the edge-face of junction ground and polished obliquely at an angle of 30° or so, and oppositely so, instead of perpendicularly to the plates; the two halves are then cemented together in the usual manner for a biquartz, with Canada balsam, in order to make a continuous plate. On placing the plate of this construction possessed by the author on the stage of the projection polariscope, the two halves exhibit on the screen respectively brilliant red and green colour, with a vertical central black band, and on each side of it first a white strip and then a spectrum band, all the bands being parallel to each other, and the whole effect being precisely what was observed with a natural biquartz of about the same thickness.

Thus, we have imitated the oblique junction of the twin parts of the second and third biquartzes, and proved that this obliquity is the reason for the phenomenon of bands, the black band occupying the centre where the two opposite rotations of the right and left quartz are precisely neutralised. The dark field of the crossed Nicols consequently prevails along this central strip, for the rotatory effect of the first individual crystal on the light passing through it is exactly undone by the subsequent passage of the rays through the other individual. On either side of this neutral strip there is a little preponderance of right-handed quartz on one side, and of left-handed quartz on the other, and the usual effect of a thin plate of quartz is therefore seen, namely, no colour but a little light, while further accretions of thickness of the preponderating variety give all the colours of the spectrum in turn, as with growing thicknesses of ordinary single quartz plates, thus producing the spectrum band.

The black band is also afforded when the plate is cut somewhat obliquely, out of a twin crystal with a junction plane truly perpendicular to the equatorial section, instead of cutting it truly

perpendicularly to the axis, the junction plane being then oblique to the plate. The polarisation colours are not so strong, however, unless the plate be made thicker.

This effect of a black band with flanking spectra is very similar to that obtained, due to double refraction and not to optical activity, when two thin wedges of quartz are cemented together to form a parallel plate, one wedge being cut so that the optic axis is parallel to the edge of the wedge, and the other with the optic axis perpendicular to the edge. When such a composite plate of quartz, known as a Babinet plate from the name of its first constructor, is placed on the stage of the polariscope, and rotated to the 45° position with respect to the planes of vibration of the crossed Nicols, there is observed on the screen a deep black band in the centre parallel to the edge of the wedge and a number of spectrum bands on each side, separated by white equal interspaces, the rainbow-coloured bands showing the orders of Newton's spectra. The effect, as seen on the screen, is reproduced photographically in black and white in Fig. 132, Plate XXIV.

These experiments lead us naturally to the study of a great variety of quartz twins, involving some of the most beautiful and gorgeously chromatic phenomena which it is possible to produce on the screen with the projection polariscope. They will eventually bring us to the study of amethyst quartz, in which the twinning is repeated so often that the laminations of alternate right and left quartz are sometimes countless, and almost approach molecular dimensions.

The Brazilian twinning of quartz, parallel to a pair of faces of the second order hexagonal prism $\{11\bar{2}0\}$, often occurs in a very erratic manner, as regards the arrangement of the portions of the composite crystal belonging to the two varieties, the surfaces of contact and character of the interpenetration being frequently very irregular, and often remarkably so. Thus Fig. 133, the upper figure of the coloured frontispiece, gives some faint idea of the appearance presented on the screen by a very beautiful quartz plate, one-half of which is entirely composed of left-handed quartz, giving a rich even rose-red colour when the Nicols are crossed, not very far from the violet transition tint, the plate being nearly 7.5 mm. thick, while the other half consists of an alternation of strips of right and left-handed quartz, joined obliquely to the surface of the plate, the black band and its accompanying white ones and spectrum bands being repeated two or three times before the edge is reached. This is a very instructive case, for it shows in this half of the plate, on a large scale, what occurs in amethyst in a more minutely structural manner, the broad strips, the sections of plates upwards of a quarter of an inch thick, of alternating

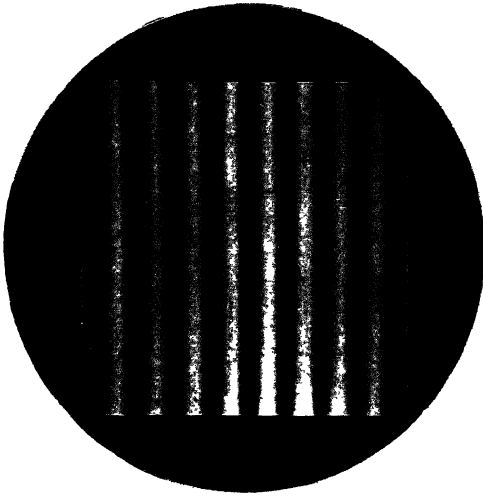

FIG. 132.—Black Central Band and equidistant Spectrum Bands on each side, afforded by Babinet's Composite Plate of two Quartz Wedges, one parallel and the other perpendicular to the Axis. (Direct Photograph of Screen Picture as projected by Lantern Polariscope)

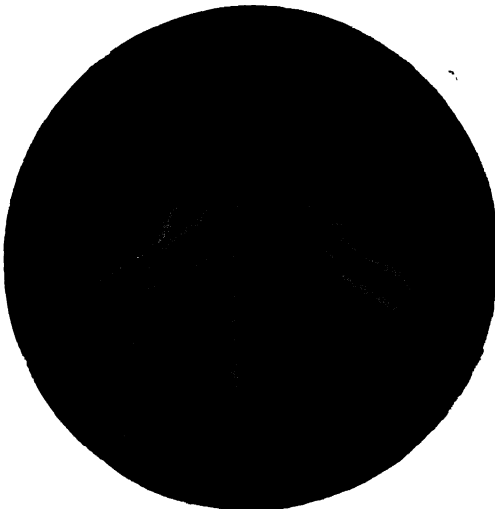

FIG. 134.—Sectorial 60° or 120° Intrusive Twinning of Right and Left-handed Quartz, showing Ribbons with Central Black Band where Oblique Overlapping occurs

character becoming in amethyst thin lines, the sections of laminae or films of microscopic tenuity, their number being correspondingly enormously increased.

It may be interesting to state how this Fig. 133 and the lower Fig. 140 of the frontispiece representing the projection on the screen of benzoic acid in the act of crystallisation were produced. The pictures on the screen were directly photographed on the latest Lumière autochrome plates, a transparency in the actual natural colours being thus obtained in each case. These transparent colour-photographs were then used as originals wherewith to reproduce the effects on paper by the most recent improved three-colour photographic process.

Two other typical cases of irregular quartz twinning may also with advantage be demonstrated. The first is a plate in which there are repeated 60° V-shaped or 120° wedge-shaped intrusions of one variety into a greater mass of the other variety. The border of the V or 120° wedge is composed of a ribbon, the outer edges of which are spectrum-coloured and the central line of which is formed by the deep black band, which is separated on each side from the spectra by a white strip. Some idea of the beauty of this quartz plate, as projected on the screen under crossed Nicols, may be gathered from Fig. 134, Plate XXIV, the upper homogeneous part of the plate being coloured a brilliant green, and the lower part red.

The second is an irregular interpenetration of one variety into the other, in repeated V-shapes occupying the lower half of the image of the plate as seen on the screen in the dark field of the projection polariscope, like a range of sharp mountain-peaks, the black bands being so rapidly repeated as to be nearly continuous. These darker portions thus appear to form the bulk of the mountains, while the upper untwinned half of the crystal shows a clear and even sky-blue; to make the resemblance to a range of Alpine mountains even more complete, the wavy line of demarcation between the twinned and non-twinned portions of the plate is bordered by a white ribbon, of varying width, giving the appearance of a snow-cap to each peak, which shows up clearly against the blue sky. It will be obvious that this quartz plate affords an altogether very beautiful series of phenomena in parallel polarised light on the screen, for the colours change with every movement of the analysing Nicol from the crossed position, the appearance for which has just been described. Fig. 135, Plate XXV, gives only the faintest idea of the beauty of the screen picture afforded by this section-plate. The effect chosen as best for photographic reproduction purposes is one afforded when the analysing Nicol is rotated somewhat away from the crossed position with respect to the polariser.

And now we arrive finally at amethyst quartz, three very beautiful hexagonal plates of which—cut perpendicularly to the optic axis as usual for quartzes intended to display optical activity, from an apparently single hexagonal prism in each case—will be taken as typifying the phenomena exhibited by this especially interesting variety of quartz on the screen in parallel polarised light. The smaller one affords a screen picture, with Nicols not quite crossed, such as is portrayed in Fig. 136, Plate XXV. We observe that the area of the hexagon is roughly divisible into six 60° -sectors, and that alternate ones are uniformly coloured, indicating that they belong to wholly right-handed or left-handed quartz; whereas the other alternate sectors are most beautifully marked, as if by line shading parallel or inclined at 30° to the edges of the hexagon, by a considerable number of equally spaced dark or slate-coloured bands, close together but separated by white bands, with a trace of spectrum colours along the middle of the latter. If we rotate the analysing Nicol somewhat we can readily find a position, which is not always that of crossed Nicols, for which these parallel bands of lamellar twinning are most clearly defined, as shown in the illustration, the colours of the other sectors ever changing during the rotation.

It is obvious that we have here to do with the same phenomenon as was illustrated by the parallel bands shown on the large scale by the section illustrated in Fig. 133 of the coloured frontispiece, the black, white, and spectrum-coloured bands being simply repeated very many more times in the same space, and in alternate sectors of the crystal.

The twinning of amethyst in 60° -sectors is very characteristic of this variety of quartz, and it is an interesting fact that the sectors which show the lamellar bands in polarised light often appear purple-coloured in ordinary light, the tint from which amethyst derives its name. This is not necessarily or always so however, and the section just described and illustrated in Fig. 136 appears quite colourless throughout on casual inspection in ordinary light, in fact as a clear colourless hexagonal section of ordinary simple quartz; a trace of the amethyst colour becomes, however, apparent on closer examination when held obliquely, in the sectors where the bands become visible in polarised light.

The second plate of amethyst is a magnificent section 9 millimetres thick and $2\frac{1}{2}$ inches in diameter, of which alternate 60° sectors are deeply amethyst-coloured, the tint being a pure violet of about the wave-length of the hydrogen line near G of the spectrum. Moreover, even to the naked eye when the specimen is held in the hand up to the light, in certain positions the laminae become visible as more deeply shaded violet line markings. On



FIG. 135.—Irregular Intrusive Twinning of Right and Left-handed Quartz



FIG. 136.—Section-plate of Amethyst Quartz, showing Sectorial Repeated Twinning of the Right and Left Varieties

DIRECT PHOTOGRAPHS OF REMARKABLE SCREEN PICTURES AFFORDED
IN PARALLEL POLARISED LIGHT BY SECTIONS OF TWINS OF
RIGHT AND LEFT QUARTZ

placing it on the stage of the polariscope but with the analysing Nicol removed, so as to observe the natural appearance of the section in white light (for, although polarised by the polarising Nicol, being unanalysed the section exhibits no polarisation effects), these facts become clear to everyone in the room. The violet staining of alternate sectors appears very deep, and traces of lamination in the violet parts are just apparent on close scrutiny, the other alternate sectors appearing colourless and unmarked except by a few flaws almost always present in so large a section-plate of amethyst. The natural appearance of this plate is shown in Fig. 137, Plate XXVI, as far as is possible photographically, the violet sectors being clearly demarcated.

On replacing the analysing Nicol the colourless sectors are seen to polarise uniformly in brilliant colours, indicating a homogeneous variety of quartz in each, either right- or left-handed. In clear contradistinction, the violet sectors show the laminated twinning, but, owing to the great thickness of this plate, in too complicated (overlapping) a manner to be easily followed, a thinner plate being required to show such fine laminations clearly.

Finally, the third section is such a thinner plate, about 3.5 mm. thick and nearly $1\frac{1}{2}$ inches in diameter. This section of amethyst is probably the most beautiful of all, for it not only shows the laminated twinning to perfection, in three alternate 60° sectors and in all six in the middle part of the plate, but also these alternate sectors are distinctly violet even to the eye when the specimen is held in the hand against a white background; and the laminations are likewise also clearly visible on holding the section obliquely up to the light. In polarised light, either with crossed or parallel or anyway arranged Nicols, the phenomena on the screen are of the most superb character. The whole of the middle part of the plate appears made up of six sectors, *all* showing the fine laminar bands parallel to the edges of the second order hexagonal prism $\{11\bar{2}0\}$, that is, at 90° and 30° to the edges of the section, the crystal being a first order hexagonal prism $\{10\bar{1}0\}$. Some idea of the arrangement will be afforded by Fig. 138, Plate XXVI. The marginal parts develop into alternately right- and left-handed sectors or half-sectors, polarising in different and very brilliant colours and showing the ribbon bands at every junction; the ribbons are composed of a central black band, flanked on each side first by a white strip and then by a spectrum-coloured outer strip or border. On rotating the analysing Nicol the changes are remarkably beautiful, particularly for the positions of the analyser when the laminar bands take on their deep slate colour, with white and marginally spectral interstrips. The whole phenomena, indeed, afforded by this plate of amethystine quartz, are the most

magnificent which the author has ever seen on the screen in the whole of his crystallographic experiences.

The Brazilian twinning law of quartz, according to which the plane of twinning is parallel to a pair of faces of the second order hexagonal prism $\{11\bar{2}0\}$, appears capable of explaining all these varieties of right- and left-handed twins, the interpenetration of the intimate kind shown in Fig. 128 (page 201) usually resulting in sectorial portions of space being occupied by each kind, the surfaces of junction of oppositely optically active parts being, however, very varied in their distribution and character. Where they happen to be more or less horizontal, a plate cut perpendicularly to the axis to include both kinds would show Airy's spirals in convergent polarised light, as may readily be demonstrated by such a plate, one of several, in the author's collection. Where they are oblique, a plate cut at right angles to the axis would, as we have seen experimentally, afford the black, white and spectral ribbon bands in parallel polarised light. Where, however, the mode of interpenetration is still more intimate, we have the rapidly alternating laminae of the two varieties, right- and left-handed, building up the beautiful structure of amethyst in thin layers. A section plate of such an intimate blending of the two varieties, cut as usual perpendicular to the axis in order that any phenomena of optical activity shall be exhibited at the maximum, affords no indication whatever of optical rotation, the two varieties simply neutralising each other's effects, and the plate behaves as an ordinary uniaxial crystal, affording in convergent polarised light a black cross like calcite, complete to the centre. In parallel polarised light it shows of course the laminated structure, but the tendency to remain dark under crossed Nicols is shown by the fact that the tints exhibited by the laminations are slates, greys, and even black, when the Nicols are crossed, the delightful other colours only making their appearance when the analysing Nicol is rotated. Thus the simple law of Brazilian twinning is quite capable of explaining the whole of the phenomena exhibited by composite crystals of the two varieties of quartz, and such an explanation is the one accepted by von Groth, in the excellent description of quartz in the last edition of his *Physikalische Kristallographie*.

An interesting crystal of amethyst very similar to the third of those just described, the one illustrated in Fig. 138, was described by the late Prof. Judd in the year 1892 to the Mineralogical Society.¹ The plan of the crystal is given in Fig. 139. The wedges marked x , y , z , are of a pale yellow colour, as are also the three strips, sections of plates, proceeding from the wedges and meeting at the centre o . The wedge y exhibits left-handed polarisation, and the

¹ *Mineralogical Magazine*, 1892, 10, 123.

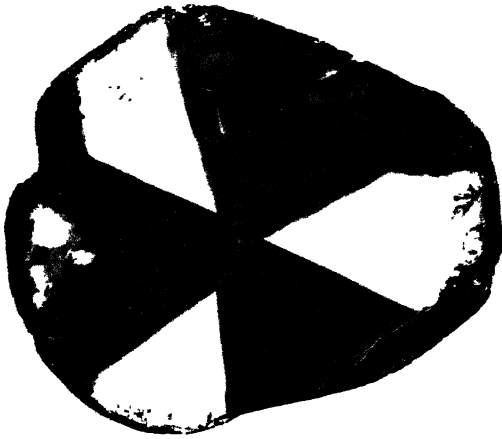

FIG. 137.—Section-plate of Amethyst, natural size, as seen directly in Ordinary Light, showing Alternate Violet Sectors (see p. 207)



FIG. 138.—Section-plate of large Amethyst Quartz Crystal, showing relatively large Area of Sectorial Repeated Twinning of Right and Left-handed Quartz (see p. 207)

DIRECT PHOTOGRAPHS OF SCREEN PICTURES OF AMETHYST PROJECTED BY THE LANTERN POLARISCOPE IN PARALLEL LIGHT

wedge z right-handed. The large wedge x is composite, the part marked x_r being right-handed and that marked x_l left-handed. The surface of junction of the two parts is not perpendicular to the plate, so where the two varieties overlap, the part marked x_b , a ribbon band is shown in parallel light and Airy's spirals in convergent polarised light. The yellow parts of the crystal exhibit ordinary rotatory polarisation colours, even tints; but in the remaining sectors of the crystal, the lines of division of which are indicated by the radial lines A, B, C, no trace of circular polarisation is displayed, and the central part, where the lamellæ are very well developed, gives the ordinary calcite-like uniaxial interference

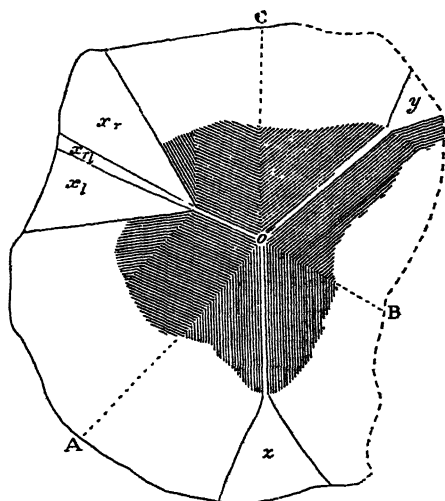

FIG. 139.—Plan of Amethyst Crystal.

figure. The more marginal portions, however, show complicated interference figures, somewhat resembling those of biaxial crystals, owing to irregular distribution of the two varieties of quartz, and probable displacement of the optic axis by distortion.

An ingenious theory of the formation of the lamellæ is put forward by Prof. Judd in the same memoir. He had already shown that quartz is endowed with planes of gliding, parallel to the rhombohedral faces, and suggests that the lamellation is the result of the effect of high pressure and possibly high temperature on the quartz crystal after its formation. The lamellæ appear to be frequently parallel to the rhombohedral terminal faces of the crystal, as if they were indeed glide plane effects. It is quite conceivable that the gliding of layers of molecules, which when permanent usually involves rotation and inversion of the molecules, might result in

alternately right and left structural arrangements, and there is considerable evidence that the development of the purple tint occurred subsequently to the growth of the crystal. It is probably due to change in the state of oxidation of the trace of manganese present as a minute impurity in the quartz crystal, and which is concentrated between the lamellæ, just as the yellow tint is due to a slight trace of iron (ferric) oxide. The theory is an interesting one, and throws considerable light on the possible nature of intimate lamellar twinning.

One last experiment may now be referred to, the concluding experiment of the Winnipeg lecture, and which is very reminiscent of the beautiful slate-colour of the lamellæ of amethyst. It is the actual crystallisation, projected on the screen, of a thin film of melted benzoic acid, which affords radiating closely packed long and narrow crystals, shooting out on the screen from centres near the margin of the field, very much like the individual crystals of repeatedly twinned quartz in the beautiful amethyst crystal illustrated in Fig. 138. Provided the film of melted benzoic acid be thin enough, the crystals appear on the screen in parallel polarised light, under crossed Nicols, tinted with the same beautiful shades of slate colour as amethyst, the intermediate low-order tint between the black and the grey of Newton's first order spectrum. Some idea of the appearance on the screen is afforded by Fig. 140, the lower of the two coloured figures in the frontispiece. As in the case of Fig. 133, the screen picture was photographed directly on a Lumière autochrome plate, and the transparency in the actual colours thus obtained was employed as an original wherewith to reproduce the picture on paper by the latest three-colour photographic process.

In carrying out the experiment a few of the flaky crystals of benzoic acid are placed on one of the circular glass object plates of the standard $1\frac{1}{8}$ -inch size for the projection polariscope; they are covered by a second similar one, and the two plates are then held in a pair of tongs and gently warmed over a small spirit lamp, or miniature Bunsen lamp. As soon as the crystals have fused, and the melted substance is evenly spread as a thin film between the two glass plates, the latter are rapidly transferred to a special mahogany object frame, fitted with a side slide to press the double-plate edge just sufficiently to hold it in position in the frame, which is then at once placed on the rotating stage of the polariscope. The screen appears quite dark at first, the Nicols being crossed, but in a second or two as the slide cools the benzoic acid begins to crystallise out at the sides, brilliant colours and the deep greys being both developed, the former chiefly near the edges of the crystals, rendering the crystallisation wonderfully distinct and beautiful

on the black background. Then long needle crystals shoot out from various quarters one after another or simultaneously, in lovely shades of slate or grey tinted with brilliant colours at the margins and tips, the growing point cutting its way along like a sharp brilliantly coloured arrowhead. Eventually an arch is formed of such acicular crystals, radiating simultaneously from many centres, gorgeously coloured in parts, but showing the yet more æsthetic slates and greys in the main. Finally, the whole screen picture fills up with a mass of interlacing yet ever distinct crystals, the last few to crystallise in the centre usually doing so with a burst of especially bright colour, as the thickness increases adequately for the double refraction retardation to reach the more brilliant second order spectrum, a concluding effect which evokes the emphatic delight of even the most phlegmatic philosopher, inured to scenes of beauty in natural phenomena.

The series of experiments with quartz described in this and the previous chapter, culminating with those revealing the alternate repetition of extremely fine layers of right- and left-handed quartz in amethyst, will, it is hoped, have illustrated and rendered intelligible the important structural principle of enantiomorphism or mirror-image symmetry. We have only to imagine the layers to become thinner and thinner until we approach ultimately the neighbourhood of the minute dimensions of the chemical molecule, without as yet penetrating within the range of the molecular forces; the two such oppositely constructed and intimately blended structures, built up by atoms arranged oppositely screw-wise, clockwise and anti-clockwise, will now form an ultra-microscopic mixture of the two varieties in equal quantities, that is, in equal molecular proportions.

Such a structure will exhibit the symmetry of the system to which the two individuals belong, but instead of only displaying that of the enantiomorphous class of that system, possessing lower than the full symmetry, as each variety does when crystallised alone, it will now display the full holohedral symmetry of the system. That is, the symmetry is enhanced by this intimate blending of the two complementary enantiomorphous forms, the two together supplying all the possible elements of symmetry of which the system is capable. Moreover, as we have seen in the case of the lamellar portion of the amethyst crystals represented in Figs. 138 and 139, there will now be no sign of optical activity, for the two opposite rotations are equal and destroy each other.

Hence, such a compound crystal shows the holohedral symmetry of the system, and is optically inactive. In such cases we are, in fact, confronted with the phenomenon of pseudo-racemism, as defined in Chapter XIV. For we know that the two varieties are

still present intact, polarised light revealing them in the case of their grosser development such as is found in amethyst, and the system of symmetry being clearly the same, the forms developed being merely the sum of those of the two individual varieties.

Amethyst thus affords us a gross demonstration of the nature of pseudo-racemism, and as such has proved an exceedingly illuminating study.

We can carry the process further, however, in imagination, until the two differently helical molecules are themselves juxtaposed face to face, right molecule to left molecule. When, however, this occurs, we have entered into that most fascinatingly interesting region, the range of molecular forces, a mysterious sphere of activities of which we are only just beginning to learn something. Within this region of larger activity the two oppositely constructed molecules are often known to combine chemically to produce a molecular compound, just as potassium sulphate molecules, for instance, will combine with those of magnesium sulphate to form the well-known double salt. The double molecule now furnishes the representative point of the space-lattice, in other words, a new space-lattice is now erected, the units of which may be taken to be the representative points of the double molecules. Such a space-lattice will of necessity be of a totally different character to the old one corresponding to the single molecule of either variety (for each variety has the same space-lattice, the points, however, representing differently, enantiomorphously, orientated atomic details). That is to say, we shall have an entirely new kind of crystal produced, in all probability belonging to a different crystal system. It is known as a racemic compound, as described in Chapter XIV.

This is exactly what happens in the case of tartaric acid, the two varieties, dextro or right-handed tartaric acid and lævo or left-handed tartaric acid, not forming pseudo-racemic crystals of like but enhanced (holohedral) symmetry, but a truly molecular compound, the well-known inactive racemic acid, in which the phenomenon of "racemism" was first discovered and from which it took its name.

Now a molecular compound is notoriously regarded by chemists as a type of chemical compound of low stability, molecular attraction or affinity not being nearly so powerful as atomic affinity. Hence, under suitable conditions it may be possible to induce the two component varieties to crystallise out separately from the solution of the racemic compound. In the case of racemic acid itself this does not readily happen, but in the cases of certain of its metallic salts, sodium ammonium racemate, for instance, specific conditions are known under which the two varieties of crystals, right- and left-handed respectively, may be separately crystallised out from the solution, some of which conditions were referred to in Chapter XIV.

Racemic acid itself, however, crystallises quite differently to the two tartaric acids, namely, in triclinic prismatic crystals. These are, in fact, absolutely different from the monoclinic crystals of the dextro and lævo varieties of ordinary tartaric acid, for racemic acid takes up also a molecule of water of crystallisation on separating from its aqueous solution. There are certain chemical differences also, due to the chemical union of the two enantiomorphous molecules into a single double molecule, such, for instance, as greater facility of reduction by hydriodic acid to succinic acid. Moreover, when the crystallisation is effected at 73° C. anhydrous racemic acid itself is deposited, also in triclinic crystals.

Thus our experiments with quartz have afforded us the means of acquiring a clear idea of the nature of this most interesting type of crystal structure which involves the principle of mirror-image symmetry. Racemic acid and its similar structures, racemic compounds in general, are known as "externally compensated" structures, the reflective principle here acting externally to the single enantiomorphous molecule. It is but another step, however, to imagine internal compensation of enantiomorphous parts of a molecule, by mirror-image combination of such parts, such as in all probability occurs in the case of the truly inactive fourth variety of tartaric acid, in order to comprehend how the principle enabled the 165 types of homogeneous structure involving this kind of repetition to be arrived at, and thus, together with the 65 regular point-systems already known, to afford us the complete set of 230 types of homogeneous structures possible to crystals.

Before concluding this chapter and the subject of this wonderful mineral quartz, reference may be made to another result of the practical absence of cleavage in quartz crystals, as it is so deeply interesting historically, namely, the fact that it is rendered possible to carve out of crystals of adequate size, which are found from time to time, vases, cups, caskets, medallions, plaques, rings, and works of art of all kinds. When one remembers that quartz is as hard or even harder than steel, only topaz, corundum (ruby, sapphire or emery), and diamond being harder, it is surprising what skill has been displayed, especially in ancient times. So durable and all but unbreakable are quartz articles that a set of standard weights have for long been a cherished possession of the Standards Department of the Board of Trade, the largest being the standard kilogram (2.2046 lbs. avoirdupois), which was cut from a single Brazilian quartz crystal of very large size and quite flawless. Necklaces, seals, and engraving cylinders of quartz were in common use by the Assyrians, Babylonians, and ancient Egyptians. Theophrastus, writing in the fourth century B.C., refers to rock crystal as being largely used for decorative purposes in his time. The

Romans of the Empire used elaborately carved cups and vases of quartz for their iced drinks and floral decorations. Pliny mentions a bowl of rock crystal for which a Roman lady gave the equivalent of £1,500 of our money. Nero, in one of his rages, is stated to have smashed two other such bowls of great value, which were engraved with illustrations from Homer. A huge sphere of quartz, recorded as being of a weight equal to fifty of our pounds, was dedicated by Livia in the Capitol, and a carved rock-crystal bowl, of a capacity equal to over two of our quarts, is also stated to have been used in the ceremony on the occasion. Much earlier, at ancient Nineveh, rock crystal spheres were used as burning glasses, and in Roman times spheres of the mineral were much employed by surgeons for the cauterising of wounds; Pliny gives many details of such usage.

Another property of quartz was also utilised considerably by the Romans, namely, its refreshing coldness to the touch, due to its good conductivity compared with glass. For instance, Propertius says:—"Oh what avails . . . that my hands the limpid crystal bear?" And again, "Now holds the flinty bulb to cool her hand." The same object thus served as a cooler in the shade, during the heat of day, and in the sunshine as a burning glass to produce the sacrificial "Fire of Vesta."

In later times, the Milanese were especially skilled in crystal-cutting, and it is recorded of Annibal Fontana, one of the most celebrated, that he made a quartz coffer for the Elector of Bavaria for which he was paid six thousand gold scudi. At the present time there are some very fine specimens of large carved cups of quartz in the Rothschild Collection at the British Museum (Waddesdon Room). A very beautiful nautilus-shaped covered cup, over a foot in diameter, is shown in Fig. 141, Plate XXVII, from the similarly superb collection of the late Mr. Alfred Simson, who was kind enough to permit the author to exhibit this lovely object, as well as several others equally beautiful, in one of his lectures to the Royal Society of Arts on Rock Crystal.

Spherical balls of quartz were also used in the Middle Ages for mystic and occult purposes. The famous "show stone" of the celebrated Dr. John Dee, Fellow of the newly established Trinity College, Cambridge, in the sixteenth century, and who died at Mortlake in 1608, was a very fine sphere of rock crystal. The recrudescence of "Crystal Gazing" in our own time has been one of the remarkable accompaniments of the Great War. Its effect has been seen in the enormous and practically prohibitive increase in the price of quartz spheres, which the author has found to his cost when requiring such a sphere of considerable size for crystallographic investigations.

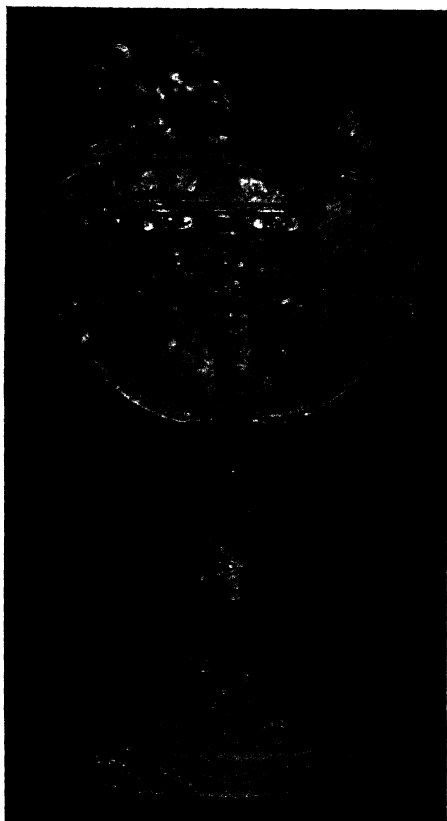

FIG. 141.—Cup carved out of Quartz Crystal

CHAPTER XVIII

“ LIQUID CRYSTALS ”

WE have seen in the foregoing pages that a crystal is a perfect solid, highly organised in a homogeneous manner, and, unless the symmetry be developed to its highest extent, the crystal then belonging to the cubic system, it is also in general optically anisotropic, that is, it exhibits double refraction. Section plates of it, more or less thin according to the strength of the double refraction, exhibit colours in parallel polarised light, and show the phenomenon of a single optic axis, or of two optic axes, in convergent polarised light. Every variety of hardness, however, is displayed, from that of the diamond down to that of a crystal as soft as gypsum, and even softer. Moreover, many of the softer crystallised substances develop the property of permitting one layer to glide over another by gentle side pressure with a knife blade, when inserted in an edge or face in an attempt to cut the crystal. Calcite and ice, for instance, both possess such planes of gliding of the structural units over one another in layers. There are also the border-line cases of crystals so soft as to be readily bent, and many well-known viscous substances crystallisable only with great difficulty, some of which form pliable crystals.

But in the year 1876 Lehmann discovered a new property in an already remarkable substance, iodide of silver, AgI , namely, that at temperatures superior to 146°C . it can flow like a viscous liquid, while exhibiting several of the properties which are characteristic of crystals. Silver iodide is dimorphous, exhibiting a hexagonal form at the ordinary temperature, which persists up to 146° . But during the heating to the latter temperature a regularly accelerating diminution of volume occurs, the feeble expansion in directions perpendicular to the axis being overbalanced by a considerable contraction along the axis, both quantities having been accurately measured so long ago as the year 1867 by Fizeau, by means of his delicate interference dilatometer. This contraction, so unusual an occurrence with increase of temperature, culminates at 146° , according to Mallard and Le Chatelier, in a sudden change of condition into a cubic modification, accompanied by absorption of heat. Now Lehmann, studying this cubic modification of silver iodide

under a microscope which he had devised—specially adapted for observations at temperatures higher than the ordinary, by being supplied with the means of heating the object under observation—found that it was not only plastic, but actually a liquid. This observation, however, has since been shown to have been due to impurity in the silver iodide employed. When care is taken to purify it, silver iodide remains quite as hard as yellow phosphorus

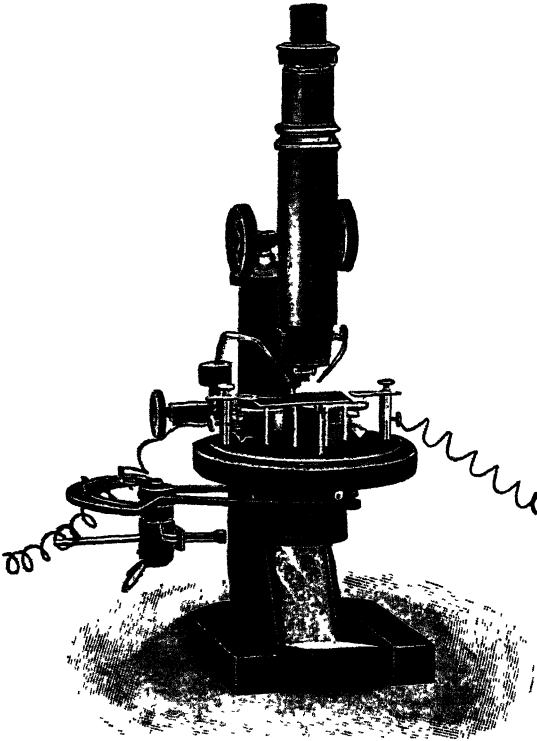

FIG. 142.—Lehmann's Crystallisation Microscope.

right up to 550° C., within 2° of its melting point. Lehmann's erroneous observation is of historic importance, however, as it led him along the train of research which has proved so deeply interesting.

The form of Lehmann's "Crystallisation Microscope," as now constructed by Zeiss, is shown in Fig. 142. Its essential features are that the glass object-plate, which is somewhat wider than the usual microscope 3 by 1 inches slip, is supported by little metallic columns at a height an inch or more above the ordinary stage, and

may be heated from below by a miniature Bunsen burner, which is provided with a delicate graduated gas-tap and is adjustable for its position, swinging in or out as desired. The small Bunsen flame may be converted into a blow-pipe flame if necessary, an air-blast attachment to a mixing reservoir being provided, to which the arm of the burner is hinged. Two cooling blasts, connected with a gas-holder of air, are also provided, and are adjustable to the most suitable symmetrical positions above the slide for directing the cooling air on the part of the latter where the liquid is situated. These arrangements enable the substance on the slide to be rapidly or slowly heated or cooled at will. Electric connections are also provided, in the event of the observer desiring to study the behaviour of the “ liquid crystals ” under the influence of the electric current.

Considerably later, in the year 1889, the attention of Lehmann was called by Reinitzer to another similarly singular substance,

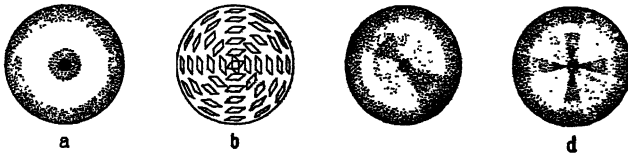

FIG. 143.—“ Liquid Crystals ” of Para-azoxy-phenetol arranged in Spherical Drops.

cholesteryl benzoate, which appeared to consist of an aggregate of minute crystals which flow as readily as oil, while preserving many of the characters of crystals.

In the next year, 1890, the substance para-azoxy-phenetol, then recently discovered by Gattermann, was observed by Lehmann to form a turbid “ melt ” on fusion, which consisted of what appeared to be an aggregate of crystals flowing with a mobility equal to that of water, and which take the form of spherical drops showing a dark kernel inside, as shown at *a* in Fig. 143, quite unlike a drop of ordinary liquid. The kernel disappears on shaking, but reappears on coming to rest again. In polarised light the drops show dichroism, that is two different colours in different parts or directions, being divided into white and yellow parts, the yellow as a pair of opposite approximately 60° sectors, as indicated at *c* in Fig. 143. Under crossed Nicols they show a black cross, as represented at *d* in Fig. 143.

Now obviously these drops are doubly refractive, and their whole optical behaviour corresponds to the arrangement of the molecules in concentric circles, such as that suggested at *b* in Fig. 143.

Another substance of like character, para-azoxy-anisol, was

subsequently found to behave similarly, and forms an excellent substance to use for demonstration purposes. A reproduction of a photograph, kindly sent to the author by the late Prof. Lehmann (who died in 1922), of a slide of this substance is given in Fig. 144, Plate XXVIII. It shows a characteristic field of such drops, exhibiting white parts and yellow sectorial parts which photograph dark, of para-azoxy-anisol mixed with a little para-azoxy-phenetol, oil and resin (colophony), as seen under the polarising microscope with crossed Nicols.

The next and possibly most interesting step in this remarkable series of discoveries was made by Lehmann in the year 1894. He alighted on the fact that ammonium oleate, $C_{18}H_{33}(NH_4)O_2$, crystallised from solution in alcohol, affords a splendid example

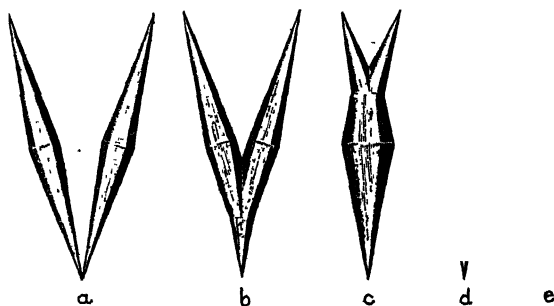

FIG. 145.—“Liquid Crystals” of Ammonium Oleate.

of “flowing crystals,” which are sufficiently large to enable their habits to be studied in detail. The individuals are almost invisible in ordinary light, owing to the refractive index of the crystals and of the mother liquor being approximately the same. But in polarised light, using crossed Nicols, they are clearly revealed as steep double pyramids with more or less rounded edges. Their section is nearly circular in consequence, and they exhibit optical properties of a uniaxial character, the optic axis being that of the double cone or bipyramid. A characteristic individual is shown at *e* in Fig. 145. When two of these “flowing crystals” approach each other, as at *a* in Fig. 145, they coalesce to form a larger single individual, as is indicated in stages at *b*, *c* and *d* in the illustration.

When the cover glass, under which they are growing on a microscope 3 by 1 inch slip, is moved to and fro so as to distort these remarkable bodies, which we may well hesitate to call crystals, the singular effect is produced of causing them all to become similarly orientated, for the extinction directions follow the direction of

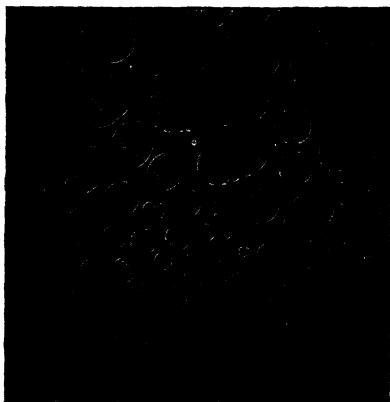

FIG. 144.—Dichroic "Crystal" Drops
of Para-azoxy-anisol

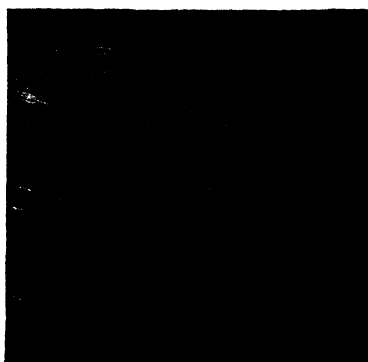

FIG. 152.—Rectilinear "Liquid Prisms" of Ethyl
Ester of Para-azoxy-bromocinnamic Acid

the pressure. They at once seek to regain their original form, however, on cessation of the disturbance. A slide of the bipyramids under pressure is shown in Fig. 146. In the black extinguished portions of the field the "flowing crystals" are flattened, according to Lehmann, and arranged so that the optic axis is in all cases perpendicular to the tabular crystals and the glass plates and parallel to the axis of the microscope. The black parts are separated by oily strips, as shown in another slide under considerable pressure, represented in Fig. 147, which are composed of the tabular crystals standing on end, with their optic axes parallel to the plates.

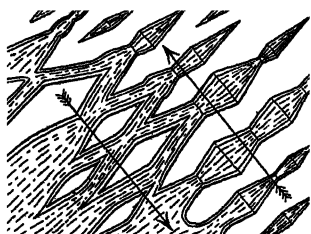

FIG. 146.—"Liquid Crystals" of Ammonium Oleate under slight pressure.

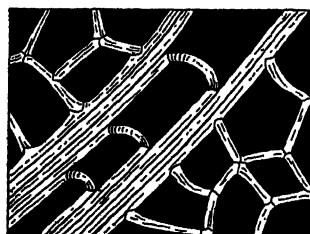

FIG. 147.—Ammonium Oleate under considerable pressure.

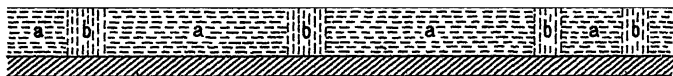

FIG. 148.—Diagrammatic Representation of Arrangement of Molecules.

These strips polarise the more brightly the more truly the crystals stand perpendicularly to the plates. The two conditions are shown diagrammatically at *a* and *b* in Fig. 148.

Lehmann believed the explanation of these singular phenomena to be that the "liquid crystals" of ammonium oleate are composed of piles or layers of thin plates perpendicular to the optic axis. Disturbance detaches the plates from their piled positions over one another, and sets them parallel to the glass plate, except in places, the oily strips, where the plates stand upright, perpendicularly to the micro-slip and cover-glass. Lehmann, indeed, went further, and asserted that the molecules themselves are anisotropic, and probably take the form of plates.

An extremely interesting experimental observation of Lehmann's with the bipyramids of ammonium oleate is, that if one of them, for instance *A* in Fig. 149, be broken into parts, as at *B*, each part

grows again and completely repairs itself, becoming once more a perfect double pyramid, as indicated in stages at C and D in the figure.

Twins of ammonium oleate are also shown in Figs. 150 and 151, the former figure representing a twin of cruciform character, and the latter exhibiting twins resembling a boomerang and an arrow-head respectively.

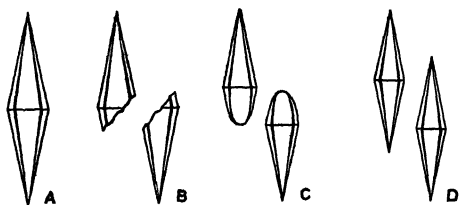

FIG. 149.—A "Crystal" of Ammonium Oleate A, broken at B, each part repairing itself at C, perfect again at D.

This substance, ammonium oleate, thus appears to be one of the most remarkable and interesting of all the bodies yet observed to afford "liquid crystals." Many other oleates produce "liquid crystals" also, but the ammonium salt is by far the most striking, and very convincing as to the reality of Lehmann's discovery.

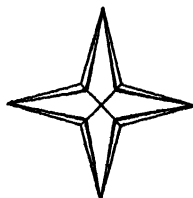

FIG. 150.

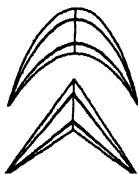

FIG. 151.

Cruciform, Boomerang, and Arrow-head Twins of Ammonium Oleate.

Another substance of a different nature was discovered by Vorländer in the year 1904, namely, the ethyl ester of para-azoxybenzoic acid.

The individuals are described by Lehmann, who further studied the nature of the substance, as almost perfectly rectilinear prisms with nearly sharply defined basal-plane end faces. A singular fact about the substance is, that when two individuals approach each other they arrange themselves parallel with a jerk, and then flow into each other, producing a single larger "liquid crystal," and often with such rapidity that the eye can scarcely follow the

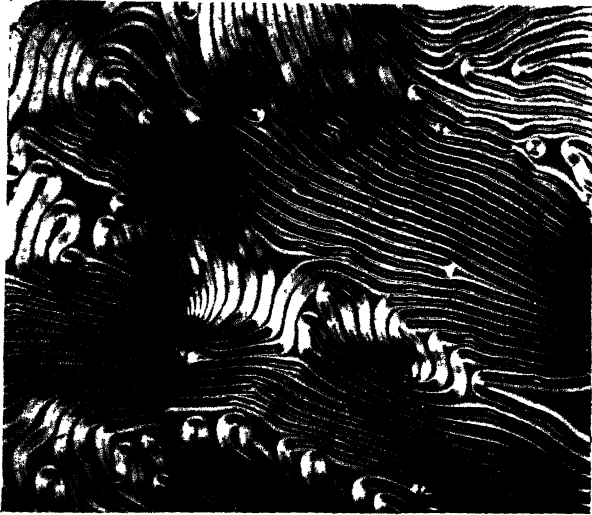

FIG. 153.—Elongated "Liquid Crystals" of Dibenzal Benzidine, showing Double Refraction and Dichroism

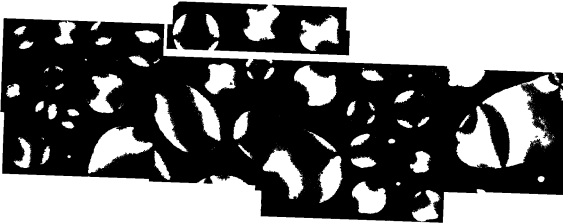

FIG. 154.—Spherical "Liquid Crystals" of Para-azoxy-anisol, showing Interference Colours under Crossed Nicols as the Effect of Compression

movements. These coalescences appear to be occurring all over the field at once, with the production of larger and larger crystals. Indeed, Lehmann likens it to a struggle between the innumerable individuals, in which the smaller ones are being continually eaten up by the larger.

Vorländer also prepared the ethyl ester of para-azoxy-bromo cinnamic acid, and a characteristic microscope slide of it in ordinary light is shown in Fig. 152, Plate XXVIII, which is a reproduction of an actual photograph most generously sent to the author by Prof. Lehmann. Lehmann found it to be similarly interesting. The substance separates from a solution in monobromonaphthalene in uniaxial prisms or hemimorphic pyramids, the edges and solid angles of which are more or less rounded, and which appear colourless in the direction of the axis and yellow in all other directions. When pressed between the cover-glass and the micro-slip on which the crystallisation is proceeding, extinction of the light occurs throughout the whole mass when polarised light is being employed and the Nicols are crossed. For throughout the entire substance the particles—whether they are the molecules themselves as Lehmann asserts or aggregations of them in the form of ultramicroscopic crystals—arrange themselves with their optic axes (the crystals being uniaxial) perpendicular to the cover-glass and micro-slip, as in the case of ammonium oleate. Lehmann's theory is that the molecules themselves are tabular perpendicular to the axis, as in the case just referred to, and that they are thus readily coerced by the pressure of the flat cover-glass to take up positions parallel to it.

Two further reproductions of photographs, taken in polarised light, of a somewhat remarkable character, which have also been placed at the author's disposal by the courtesy of Prof. Lehmann, are given in Figs. 153 and 154, Plate XXIX. Fig. 153 represents numerous doubly refractive and dichroic strips marking the boundaries of elongated individual "crystals" of the substance dibenzal benzidine, and affords a graphic idea of the real character of the double refraction displayed by "liquid crystals."

Fig. 154 represents the effect of compression on para-azoxy-anisol, and demonstrates very clearly the distribution of the interference colours due to double refraction.

It should also be mentioned that proof of the double refraction of the "liquid crystals" of several different substances, derivatives of cinnamic acid, was afforded during the year 1910. Direct measurements were carried out by two independent investigators, Dorn and Stumpf, of the two refractive indices corresponding to the ordinary and extraordinary rays in each case.

We are thus face to face in these remarkable experiments with

some new facts concerning the borderland between ordinary liquids—singly refractive and structureless, in which the molecules are rolling over each other with every possible orientation—and solid true crystals possessing homogeneous structure, and the basis of which is a space-lattice arrangement of the chemical molecules, determinative of the system of symmetry displayed. In this wonderful borderland we certainly have had revealed to us, by the genius and persistency of Lehmann, liquids which possess many of the attributes of crystals, such as definite orientation of the ultimate particles, double refraction, and optic axes.

Lehmann's theory cannot, however, be accepted in full, in the light of recent researches carried out by several independent investigators, as will presently be shown. We are now becoming familiar with the phenomena, as they have naturally excited immense interest in all scientific circles, and numerous demonstrations of many of the experiments of Lehmann have been given in this country, for instance, in a lecture at the Royal Institution delivered by the author, for which Prof. Lehmann sent over some exquisite photographs, which were reproduced as transparencies for screen projection. Prof. Lehmann himself has described the phenomena so clearly and fully that it is quite easy for others to repeat his experiments, and doubtless time would often be much better spent in doing so than in criticising points of theory without observing the phenomena at first hand. It frequently happens, in the inevitable march of scientific progress, that striking new facts, such for instance as the discovery of the composite nature of the chemical atom, are apt to cause either alarm, even panic, as to cherished theories, or else unreasoning scepticism. The happy mean between these two modes of receiving such facts, the open philosophic mind, ever ready to widen the scope of the horizon when a novel supposition is indubitably proved to be a real fact, and to assimilate that truth into the theory, widening correspondingly the scope of the latter if needful, is obviously the ideal thing to cultivate, and one which eventually finds itself in harmony with the authenticated final results of the new discoveries. It usually happens that too sweeping conclusions are at first drawn from such new facts, but time, with its further wealth of experience, especially the accumulation of experimental *data* which it brings in its train, soon levels these down and relegates the facts to their proper positions in the great scheme of natural knowledge.

Lehmann's view was that the ordinary effect of surface tension to cause truly liquid particles to assume the spherical "drop" form is resisted by a special force, which he termed "Gestaltungskraft," and which we may perhaps translate "Configuration-determining force." This force he considered is not identical with that of elas-

ticity, but is that force by virtue of which a "flowing crystal" continually seeks, while freely swimming in the mother liquor or fused liquid, to take up its normal configuration. Even if a spherical drop could be cut out of it, the sphere would at once become a rod, prism, or pyramid or whatever the normal configuration of the flowing crystals of the substance in question might be. The much debated term "liquid crystal" has been given by Lehmann to the normal configuration of each of the now considerable number of substances which have been discovered to exhibit the phenomena of "flowing crystals." The two terms "liquid crystal" or "flowing crystal," are placed within inverted commas in this book because the author feels it to be impossible to go the whole way with Lehmann, in considering these remarkable bodies as true crystals, while appreciating very highly the work of the late Prof. Lehmann in making us acquainted with the extraordinary properties of these substances.

As already indicated, Lehmann attributed the whole phenomena to a fundamental cause, namely, anisotropy (optical dissimilarity in different directions) of the molecules themselves, which he considered must cause self-restoration of the structure after disturbance, a process which he termed "spontaneous homœotropy." He considered that it is the molecular configuration-producing force, connected with the tabular form of, and directionally differentiated distribution of energy and force in, the single chemical molecules, which maintains the inner structure of the "flowing crystal" in position. The polyhedral outward form would thus appear to be a necessary consequence of the inner structure, on this basis that it is a force resident in the molecules themselves which produces the structure.

Lehmann, however, with the natural enthusiasm of the discoverer of one of the most remarkable facts for which the last few decades have been famous, undoubtedly carried his theory too far, and particularly in that part of his work, to which the author has not hitherto referred, in which he described certain phenomena of "flowing crystals" as akin to the movement of living organisms such as bacteria, and thus brought even some of the sound facts under the criticism of the sceptic more than might otherwise have been the case. But the one incontrovertible thing stands out plainly, namely, that the "flowing crystals" with which he has made us acquainted are an indubitable experimental fact, although whether they are really crystals is another matter. They are formed by a relatively few substances of very complex molecular constitution, involving a large number (see the formula of ammonium oleate on page 218) of atoms arranged in an elongated chain; they are mostly compounds of carbon, and in number

possibly not one per cent. of the innumerable substances known to produce ordinary solid crystals. It will be shown presently that they are probably of the nature of an intermediate link between true crystals and liquids. It is advisable first, however, to state a few definite facts concerning them, and to describe some experiments which will more clearly demonstrate their properties.

In the first place, as regards the facts, there can be no doubt that Lehmann has made one point very clear, which at once removes an objection long felt by the author to the purely geometrical theory of crystal structure, namely, that the chemical molecule is endowed with a directive orientative force, which is certainly concerned in crystallisation. To assume, as has been done, just because it is not necessary from the point of view of the geometrician in developing his possible homogeneous structures, that no directive force is operative in crystallisation, and that all is a mere question of the most convenient mechanical packing of the molecules, and ultimately of the atoms themselves, is, in the author's opinion, going beyond what the experimental facts justify. If Lehmann's discovery of "flowing crystals" does nothing more than return to the molecule the property always hitherto attributed to it, of possessing in itself some directive force by reason of which it arranges itself homogeneously by mutual accommodation with its similarly endowed fellow molecules, when its motion in the liquid state has been sufficiently arrested by its approach to its fellows within the range of molecular action (which the author has conclusively proved¹ to be four or five molecular diameters), either by cooling or the falling out of previously separating solvent molecules, it will have achieved a notable thing. The latest work of Sir William Bragg, on the X-ray analysis of the crystal structure of organic compounds has, moreover, fully confirmed this.

What does occur at the moment of crystallisation is at the present time one of the most interesting unsolved questions in crystallography, and one calling most urgently for solution. Attention was directed to the problem in Chapter VI, in connection with the suggestive work of Miers on vicinal faces. It was shown that it was only when the directive force had time to come properly into operation that the primary faces of fundamental importance were produced, and that when the crystallisation was rapid vicinal faces formed instead. Lehmann believed that a single kind of chemical molecule is only capable of producing a single specific space-lattice, and that polymorphism is due to alteration of the molecules themselves at the critical temperature of transformation.

¹ A very careful summary and analysis of the physical researches bearing on this question was given in the author's memoir, "On the Nature of the Structural Unit," *Journ. Chem. Soc.*, 1896, **69**, 507.

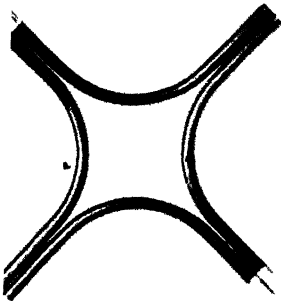

FIG. 155.—Tetragonal Astatic Magnet-system

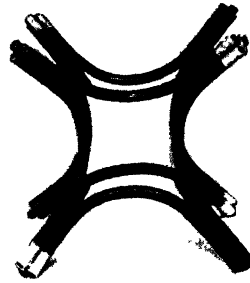

FIG. 156.—Cubic Astatic Magnet-system

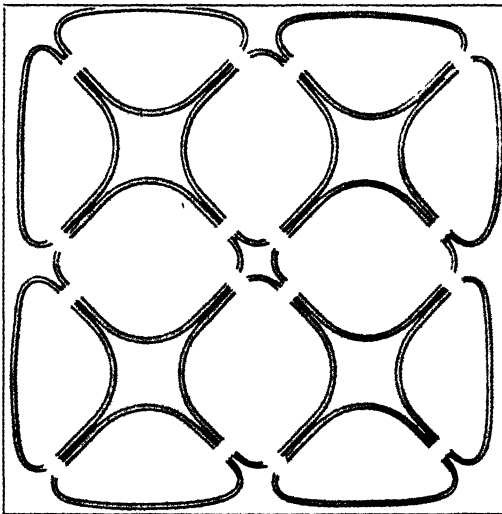

FIG. 157.—Arrangement of Astatic Magnet-systems in a Plane

He showed so far back as 1872 that this limit could be actually observed under the microscope, as a definite line of demarcation between the two varieties as the temperature fell, one side of the field attaining the critical temperature slightly before the other, and the defining line between the two kinds thus travelling over the field. Internal friction did not appear to Lehmann to enter into the question at all, as he considered it would have done if a rearrangement of the molecules were the sole cause of the change. The molecules themselves, he states, must have been undergoing change, and such rearrangement of them as occurred must have been due to that fact.

Lehmann suggests a very interesting explanation of the molecular orientative force of configuration, namely, that it is due to the action of the negative electrons or electronic corpuscles (forming, as we now know, with the positive nucleus, the elementary atoms) rotating in the molecule. For the molecules of "flowing crystals" behave like freely suspended astatic systems of magnets, which are constantly setting themselves, even while moving about, in what is something like a crystalline space-lattice. He suggests that the molecules are really magnets the poles of which mutually attract and repel one another; that two equal magnetic molecules are arranged alongside with opposite poles against each other, thus mutually binding each other, or that four horse-shoe magnets may be arranged with opposite poles together, in a tetragonal astatic system, as shown in Fig. 155, Plate XXX. The latter may be grouped in space in a cubic astatic system, as represented in Fig. 156, Plate XXX; while Figs. 157, Plate XXX, and 158, Plate XXXI, are further suggestive of how a homogeneous structure of such astatically distributed molecules can be built up, Fig. 157 representing a single plane of them, and Fig. 158 the complete arrangement in space.

An astatic system of molecules of this nature would have lost all power of attraction by a magnet, and the fact would thus be accounted for that no striking crystallographic results have ever attended experiments on crystallisation in a magnetic field. Astatic systems, however, such as that shown in Fig. 155, would certainly arrange themselves in space-lattices. For such parallel arrangements would, in general, involve differences in different directions, with regard both to internal friction and to the power of thermal expansion and of such regular dilatational or other deformational changes as we know are provoked by different physical conditions of environment. These differences would naturally, in turn, give rise to external polyhedral form.

These theoretical ideas of Lehmann have naturally called forth much discussion, criticism, and scepticism. But, so far, his experi-

mental facts have been fully substantiated by further investigation. Much more practical work is urgently required, however, before the subject can be considered as laid on a secure foundation. So much may be said, however, that it is clear that we must concede the existence of a directive force of crystallisation, and not be led by the pure geometry of the subject of crystal structure to ignore facts of such interest and undoubted importance as have been brought into prominence by the remarkable work of Lehmann.

A further interesting contribution has more recently been made by Vorländer¹ to the facts regarding the relationship between chemical constitution and the formation of "liquid crystals." It must have already struck the reader that most of the substances which exhibit liquid crystals are composed of a large number of chemical atoms, being either long-chain compounds of the fatty acids or complex derivatives of the hydrocarbon benzene, C_6H_6 ; also that many of the latter are "para" compounds, that is, derivatives in which the substitution groups are inserted in the benzene ring of six carbon atoms in the "para" position, which is that at the opposite corner of the hexagon to the carbon atom to which a substitution group has already been attached. This renders the para compounds the most extended in a straight line of all the benzene derivatives. Now Vorländer finds that a particularly favourable condition for the production of "liquid crystals" is a linear structure of the molecule. As the para substitution products of benzene derivatives possess this elongated structure, many of them exhibit the development of "liquid crystals." The more linearly extended the structure becomes, that is, the longer the straight chain of atoms is, the more favourable become the conditions. The advent of a third substitution group, however, which would have the effect of producing a kink in the chain, or of bending it, appears to destroy the possibility of the production of "liquid crystals." This interesting observation may afford the key to many of the extraordinary phenomena of "liquid crystals" which have been described, and is undoubtedly one of prime importance. Further favourable conditions for the formation of "liquid crystals," according to Vorländer,² are the aromatic character, and the presence of the doubly-linked carbon and nitrogen groups $C : C$, $C : N$, and $N : N$, which are usually so rich in energy.

A very rational explanation of the phenomenon of "liquid crystals" has been given by Bose,³ whose views have come to

¹ *Ber. der deutsch Chem. Ges.*, 1907, **40**, 1970.

² *Zeitschr. f. Phys. Chemie*, 1907, **57**, 357.

³ *Physikal. Zeitschr.*, 1907, **8**, 347 and 513; 1908, **9**, 708; and 1909, **10**, 32 and 230.

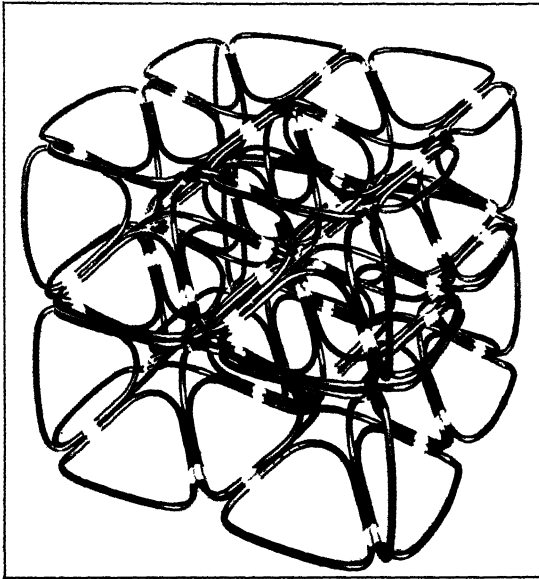

FIG. 158.—Arrangement of Astatic Magnet-systems in Space

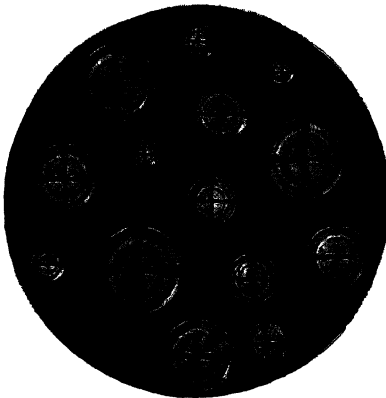
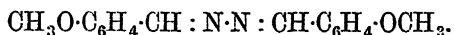

FIG. 161.—Spherulitic Crystals of the solid form of Cholesteryl Acetate, projected on the Screen in the Act of Growth (see p. 232) from the Doubly Refracting "Liquid Crystal" form

be known as “ the Swarm Theory.” They are based on the observations of Vorländer just referred to, that the molecules of the substances in question are of exceptional length. For instance, one of them, anisaldazine, has the constitutional formula :—



When two such molecules approach one another within half their length their free rotation becomes prevented, except about the direction of their length as axis, so that a parallel arrangement of the molecules becomes effected. A bundle or “ swarm ” of such parallelwise arranged molecules assumes the symmetry of a rotation figure, and behaves optically doubly refractive, very like a uniaxial crystal. Each swarm will be clear, but owing to the scattering of light between the swarms turbidity of the liquid is observed. The sudden clearing which occurs on heating beyond the temperature at which this turbidity is observed is due to the breaking up of the swarms as the temperature rises, and the attainment of the moment at which they become smaller than the wave-length of light.

When the experiment is performed as usual between the micro-slip and the cover glass, the parallel molecules of a swarm are generally found to place themselves perpendicularly to the plates, as shown at *b* in Fig. 148, owing to molecular cohesion, and it is in such a position that they exhibit the uniaxial figure of cross and rings in convergent polarised light. Now, no biaxial interference figures in convergent polarised light have ever been observed to be afforded by any substance producing “ liquid crystals,” all the figures so far observed having been uniaxial ones. The properties of dichroism, double refraction, optical rotation, and uniaxiality are all consistent with Bose’s swarm theory. They all indicate structure, but not necessarily anything further than the intermediate kind of structure exhibited by the “ swarm ” of Bose, a stage between the true liquid of freely over-rolling molecules and the true crystal-solid of space-lattice structure. The swarm would show optical rotation when the molecules themselves were enantiomorphous, as those of several of Vorländer’s substances are.

It would thus appear to be probable that these anisotropic (doubly refractive) liquids are not liquid crystals in the true meaning of the term, and, indeed, are not crystals at all, but molecules organised in an intermediate manner between those of a liquid and those of a crystal, largely due to their inordinate length and assisted by their viscosity. They possess no space-lattice structure, which is the mode of organisation characteristic of true solid crystals, but only the parallelwise arrangement of the molecules characteristic of the swarm. Attempts to discover a space-lattice structure in them by X-rays have all failed. The most important of these were

carried out by J. S. van der Lingen in the laboratory of Prof. von Laue, with *p*-azoxyanisol, *p*-azoxyphenetol, anisaldazine, and active amyl cyanobenzylidene-aminocinnamate; but no trace of a space-lattice was revealed, only indications of a parallel arrangement of molecules.

In the author's opinion this conclusion renders these substances even more interesting than if the complete view of Lehmann, that they are liquid crystals, were correct. Moreover, such a rational conclusion leaves untouched and fully valid the geometrical theory of solid, fixed, crystal structure, based on the 230 point-systems and the 14 Bravais space-lattices under which these point-systems may be grouped, a theory which may now be said to be established beyond all possibility of doubt. At the same time the molecular directive force, so clearly revealed in Lehmann's experiments, is unaffected by the acceptance of the conclusion, and, indeed, is quite in accord with it.

The phenomena of "liquid crystals" lend themselves admirably to screen demonstration, for which purpose an excellent improved form of the crystallisation microscope of Lehmann, shown in Fig. 159, is constructed by Zeiss, and its actual use in the projection, with the aid of the well-known Zeiss electric lantern, but specially fitted for the purpose, is shown in Fig. 160. The author's British-made electric lantern, shown in Fig. 114, on page 185, of course serves equally well.

A magnification of 600-700 diameters on the screen is very suitable, employing a Zeiss 8-millimetre objective without eyepiece. This objective affords directly a magnification of 30 diameters. For ordinary eye observation an eyepiece magnifying 6-8 times is added, thus affording to the eye a magnification of about 200 diameters.

The Zeiss lantern is supplied with a self-feeding electric arc lamp, ensuring a steady light. A collective lens of extra light-gathering power is fitted in front as condenser, and from it proceeds a light-tight tube provided with a water cell to filter out most of the heat rays which accompany the light. The electric lantern with Brockie-Pell or Oliver self-feeding arc lamp, shown in Figs. 114 and 122 (pages 185 and 194), already mentioned as being equally suitable, is also supplied with a water cell; and when the parallelising concave lens is removed from the large Nicol polariser and is used on a separate stand instead, a parallel beam is afforded of precisely the same character as that provided by the Zeiss apparatus. The microscope stands on a sole plate provided with levelling screws and raised on a carrying stand sliding in the lathe-bed plinth of the optical bench, and is naturally employed in the vertical position for such work with fused substances. A mirror

inclined at 45° at the foot of the microscope directs the parallelised rays from the optical lantern through the microscope, and another above the optical tube reflects them to the screen.

The heating apparatus consists of a form of miniature Bunsen burner fitted with blow-pipe blast, the respective pressures of gas

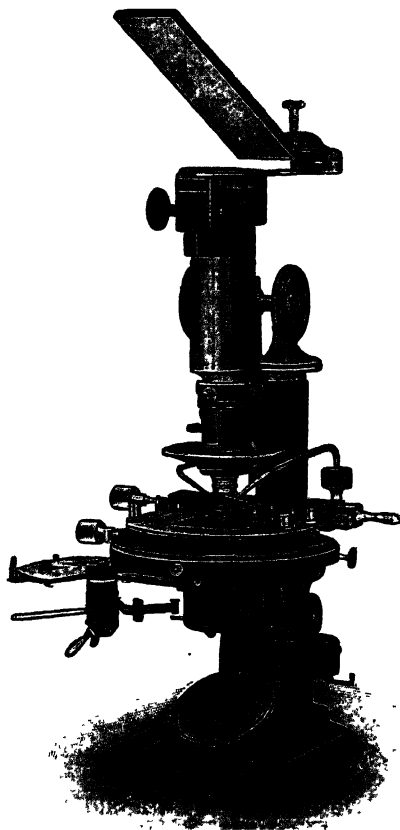

FIG. 159.—Lehmann's Crystallisation Microscope arranged for Projection.

and air being regulated by means of two taps with graduated arcs for obtaining greater delicacy of adjustment. The tabular plate seen to the left in Fig. 159 is the graduated semicircle of the two taps; below it is seen the cylindrical mixing chamber for gas and air, in the event of the necessity for using the Bunsen as a blowpipe. There are two separate attachments for india-rubber tubes to this cylinder; conveying respectively gas and air. Above the object

stage a double air-blast is fitted, each tube of which is hinged with a universal joint, so that it can be readily adjusted to any desired position on either side of and above the glass plate (supported on little metallic uprights) on which the experiment is being conducted. A polarising Nicol prism and an analysing Nicol, both constructed in a manner which protects them from the effects of heat more effectually than is the case with the usual form, are provided for obtaining the projections in polarised light. The objective and analysing Nicol, as well as the substage condenser, are also specially protected from injury by heat, by being surrounded with a water jacket supplied with running water, and a disc-like screen just above the objective assists in deflecting the heat rays from the optical tube and its Bertrand lens and other usual fittings. The miniature Bunsen flame is usually brought about an inch below the object plate, and the size of the flame can be regulated with the utmost precision, so that a fairly constant temperature can be obtained for a considerable time. With the aid of the blow-pipe air-blast, temperatures up to 700° C. can be safely employed.

The microscope shown in position on the projection apparatus in Fig. 160 is a still more recent form introduced by Zeiss, embodying several further conveniences and improvements.

The following substances lend themselves particularly well to projection purposes. Para-azoxy-anisol with resin, which exhibits the phenomenon of rotating drops; cholesteryl acetate, which affords a fine example of spherical "liquid crystals"; para-azoxyphenetol with resin, which gives beautiful interference colours; and the acetyl ester of para-azoxy-benzoic acid with resin, which shows the uniting of "liquid crystals" to form larger and larger individuals.

Perhaps the most interesting and beautiful of all is cholesteryl acetate, owing to the exquisite manner in which flower-like spherulites of the ordinary solid form, a characteristic field of which is shown in Fig. 161, on Plate XXXI, facing page 226, develop out of the doubly refractive mass of the "liquid crystal" form. In order to obtain the finest effect the heating and cooling should be carried out very slowly. The little Bunsen burner, with a very minute flame, is first placed under the slide, and allowed to act until the substance melts and forms a clear liquid. The gas jet is then removed and the air-blasts, both of which are simultaneously actuated when the tap controlling them is turned, are very gently brought into operation, one on each side of the centre of the slide, there being a good working distance of a quarter of an inch or more between the slide and the objective. The cooling is thus brought about very slowly. The Nicols should be crossed, and at this time the field is quite dark, the liquid substance being at this temperature

(well above $114^{\circ}\cdot 5$ the ordinary melting point) an ordinary singly refractive liquid.

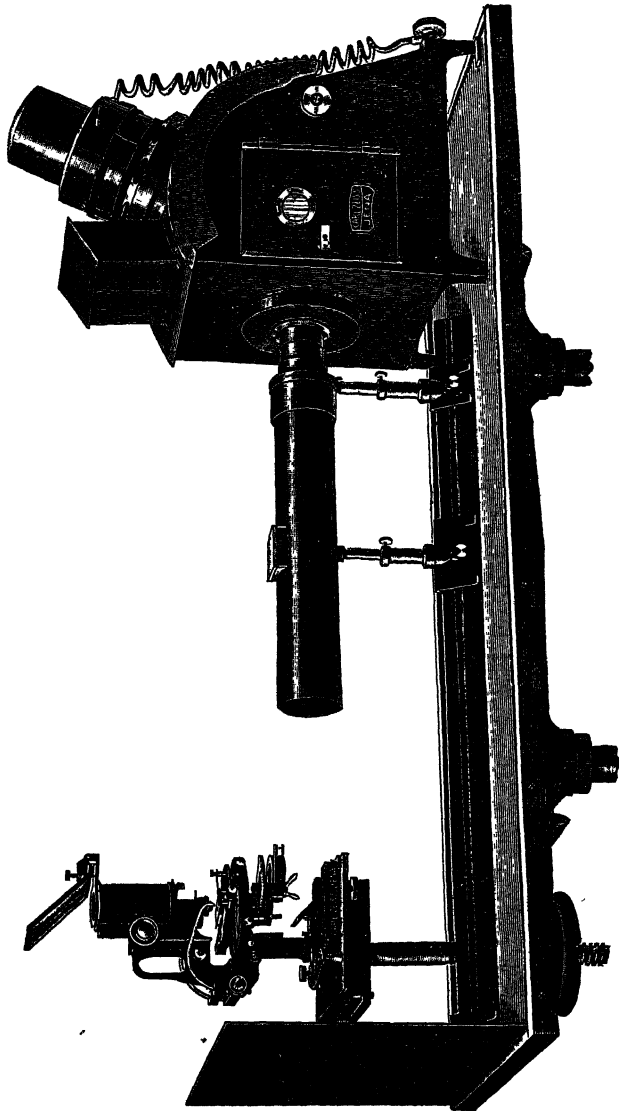

FIG. 160.—Zeiss Apparatus for the Projection of Liquid Crystals.

As soon as the temperature has become reduced to that at which the particular modification of cholesteryl acetate is produced which forms “liquid crystals,” colour becomes visible due to the double refraction of the “liquid crystal” variety. Presently,

however, spots of light make their appearance at various points in the field, and each expands into a beautiful circular and more or less coloured disc marked by a rectangular sectorial black cross, which latter is well shown in the illustration (Fig. 161). These beautiful apparitions continue to occur, and each to expand to a certain size, which is rarely exceeded, until the whole field becomes filled with the wheels or crossed discs, the general effect very much in some respects resembling that afforded by a slide of the well-known polarising substance salicine. These discs are composed of a spherulitic form of the solid variety of cholesteryl acetate. When the cooling has proceeded still further, however, there is a sudden change, and acicular solid crystals shoot over the screen, tinted with all the colours of the spectrum, until the field is full of them, this being the ordinary form of the solid modification of the substance. The experiment may be repeated with the same specimen of the substance, mounted on the same slide, covered with the usual thin cover-glass, time after time for months, at reasonable intervals.

CHAPTER XIX

OTHER PHYSICAL PROPERTIES OF CRYSTALS AND THEIR STUDY

THE conduction of heat by crystals, and their expansion or contraction on raising or lowering the temperature, are subject to very similar laws, with relation to the symmetry, to those which govern their optical behaviour. If heat conduction be supposed to start from the centre of a crystal along all directions around, and its value be represented by the length of these radial lines, they would trace out a sphere in the case of a cubic crystal, an ellipsoid of revolution in the cases of a trigonal, tetragonal, or hexagonal crystal, and an ellipsoid of general form with three unequal principal axes in the cases of a rhombic, monoclinic, or triclinic crystal. Analogously as regards thermal expansion, if a sphere were cut out of a cubic crystal, it would remain a sphere but of different radius on its temperature being altered ; but if the crystal had been one of trigonal, tetragonal, or hexagonal symmetry the sphere would become an ellipsoid of revolution, while if it had been rhombic, monoclinic, or triclinic the crystal sphere would have become a three-axial ellipsoid of general form.

The matter is not so simple as regards the elastic properties of crystals, the surface of elasticity, the envelope of all lines radiating from the centre of the crystal to represent the values of Young's modulus of elasticity, being no longer a simple sphere or ellipsoid, but a surface of greater complexity, showing protuberances and depressions. It is equally, however, a function of the symmetry, but instead of being represented mathematically by the simple equations for the sphere and ellipsoid, a much more complicated expression is involved, comprising no less than 21 constants in the most general case of a triclinic crystal. They reduce, however, as symmetry is introduced to a greater and greater extent, becoming 13 only for a monoclinic crystal, 9 for a rhombic, 7 for a hexagonal, 6 for a tetragonal, and only 3 for a cubic crystal.

The thermal and elastic movements of crystals are thus of the nature of systematic quantitative deformations, brought about by the agencies of heat and mechanical force, which are capable of, and require for their elucidation, exact measurement ; and the results of such measurements are of immense importance, as throwing light both on the true nature of crystal structure itself, and on the

character and strength of the forces between the atoms building up the structure.

The quantitative study of the physical properties of crystals other than their optical characters, such as their thermal, elastic, and electrical attributes and constants, is consequently of vast importance. But they require measuring instruments of the utmost possible refinement. For a crystal is usually but a very small object, only a very few of the hardest and naturally occurring crystallised substances being found in good single crystals suitable for such experiments and determinations. Hence, the ordinary mechanical means of fine measurement are quite inadequate, and require to be supplemented by the infinitely more refined method, involving the use of monochromatic light waves and their interference bands—a visible scale of half-wave-lengths—now happily firmly established, the method of the optical interferometer. The fine limit of mechanical measurement, by silver divided scales, verniers, and micrometers, is the two-thousandth of a millimetre or the fifty-thousandth of an inch. The scale of parallel rectilinear interference bands, produced by causing two rays of strictly monochromatic light (corresponding to a single line of the spectrum) to interfere, enables a limit of measurement of the eight-millionth of an inch to be attained. For the clearly defined dark bands themselves mark half-wave-lengths, the eighty-thousandth of an inch when red hydrogen or cadmium light is being used, and the wide intervals between band-centres can be subdivided easily into a hundred parts by a micrometer in the eyepiece of the observing telescope. Moreover, as the two rays are caused to interfere by reflecting them from two adjacent all-but parallel polished surfaces, separated by a film of air and acting as light-sources, the first of which is necessarily transparent (of glass) in order that the light may reach the second through it and be reflected back again through it, any alteration of the position of the plane of either surface so as to alter the thickness of the air-film, and therefore the path difference (twice the film thickness), causes simultaneous movement of the bands. For every band which passes the reference centre (eyepiece cross-wires, or better, a focussed minute ring silvered at the centre of the glass surface) a movement equal to one-half-wave-length of the light employed must have occurred. We have only to arrange that the second surface shall be carried by, and movable with, or that it shall be actually ground and polished on, the object to be measured or whose movement is to be measured, in order to obtain directly a measure of the alteration in size, or of the movement, of the object, in bands and hundredths (with the aid of the micrometer) of bands.

We owe the genesis of this refined mode of measurement to

H. Fizeau, who in the year 1864 used it in Paris for the determination of the expansion of crystals by heat. The crystal itself, resting on the little table of a platinum tripod, furnished the second reflecting surface, the other being the plane surface of a planoconvex lens resting on the upper ends of the three screw legs projecting upwards through the tripod table. The interference bands were curved and sodium light was used. The micrometric method of subdivision was not applicable owing to the band curvature, and sodium light is subject to the disadvantage of secondary interference and periodic disappearance of the bands, owing to the

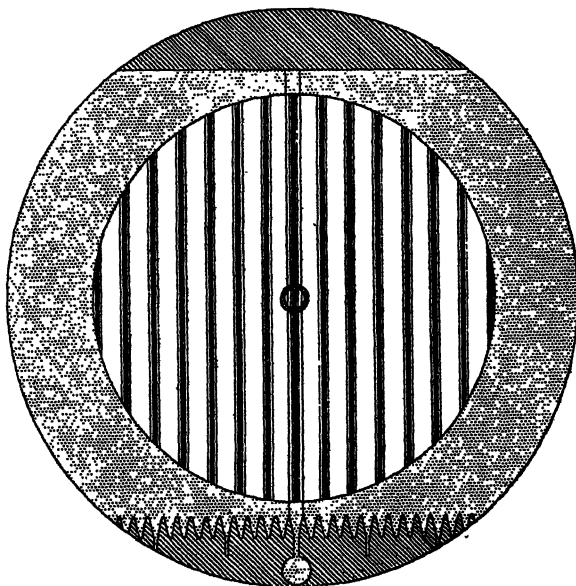

FIG. 162.—The Field of Interference Bands.

yellow sodium D line being really a double line (two distinct lines), D_1 and D_2 .

The author has, therefore, devised a greatly improved interference instrument, in which an autocollimation telescope illuminated by a Geissler H-shaped vacuum tube (of hydrogen, cadmium, or neon) is used, enabling perpendicular incidence of the light rays on the two surfaces (the ideal condition for interference) to be achieved; a glass plate replaces the lens, enabling rectilinear parallel bands suitable for micrometric purposes to be obtained, and sodium light is replaced by light corresponding to the absolutely monochromatic single red line of cadmium or the single yellow line of neon, or even for most purposes the red or green line of hydrogen,

a train of two prisms isolating the light desired. A magnificent field of straight dark bands is obtained, on a ground of the coloured

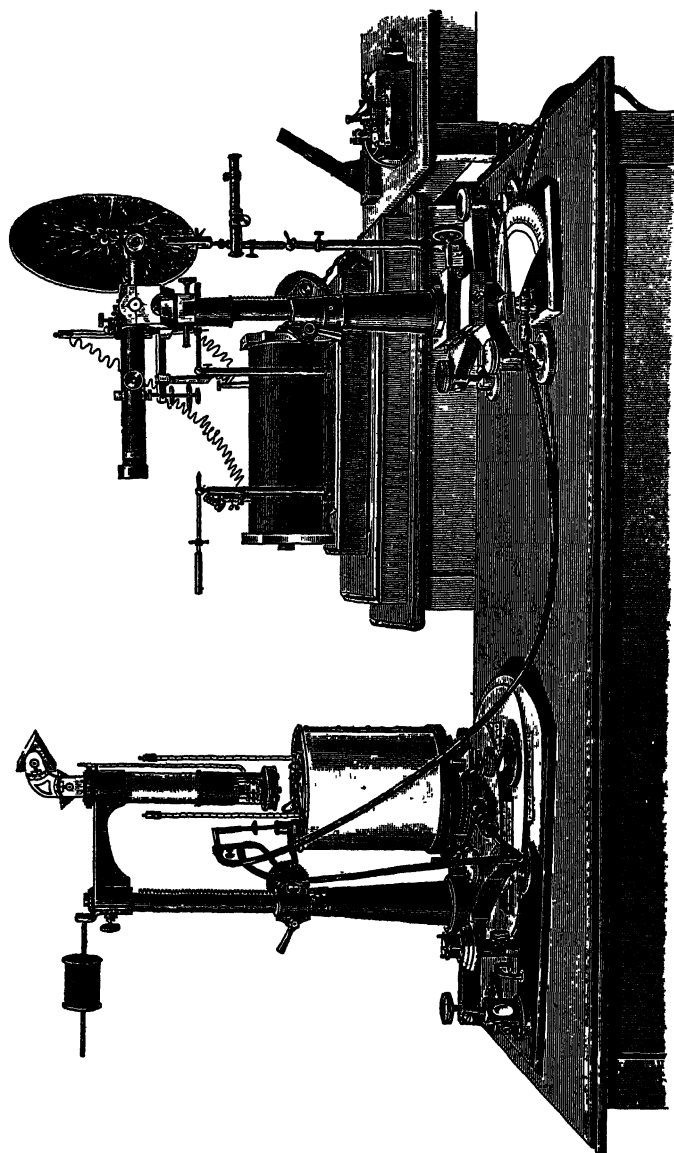

FIG. 163.—The Interference Dilatometer.

light employed, as shown in Fig. 162, and the band-intervals and any fractions are easily measured by the eyepiece micrometer. The part of the apparatus carrying the little platinum iridium

tripod, which is to be suspended in the heating chamber, is connected by a non-conducting porcelain tube with the train of dispersing prisms which directs the proper light radiation down to the glass plate and crystal carried by the miniature tripod. The whole apparatus is shown in Fig. 163.

With this dilatometer the author has determined the linear coefficients of expansion of many substances, and in particular of the normal sulphates of potassium, rubidium, and cæsium, along each of the three axes a , b , and c of the rhombic crystals, and has calculated therefrom the cubical coefficients of thermal expansion of these crystals. They have been found to exhibit a progression which follows that of the atomic weights and atomic (sequence) numbers of these three alkali metallic elements, which by their interchange form the isomorphous series, R_2SO_4 .

The author subsequently extended his interferometric method to the determination of the elastic bending of crystal bars and plates, and of small bodies in general, the optical portion of the dilatometer being used, along with elaborate devices: (a) for supporting the bar near its ends against two platinum-iridium knife-edges; (b) for bending the bar by a force applied at its centre through an agate point carried at one end of a delicate balance beam, the pan at the other end carrying the weight; (c) for transmitting the movement of the bar centre to a black glass disc acting as second reflecting surface; and (d) for controlling the application of the weight so as to produce only slow and steady movements of the interference bands. It is shown in Fig. 164, being known as the elasmometer. Young's modulus of elasticity can readily be determined by it.

But in order to determine the whole of the elastic constants of a crystal, which are different in different directions, and in a manner more complicated than can be represented by an ellipsoid like the optical and thermal constants, it is also necessary to determine the modulus of torsion, and the author's latest work has been to apply his interferometric method to the determination of the torsion of a bar of crystal or other body not procurable in large pieces. This new apparatus is shown in Fig. 165, Plate XXXII. It comprises an interferometer of universal (perfectly general) application, and a torsometer. The former embodies all the essentials of an interference comparator for standards of length, in which the author, at the invitation of the Board of Trade, adapted his interferometric method to the purposes of the Standards Department of the Board. It possesses in addition many conveniences which render it of perfectly general use for the measurement in eight-millionths of an inch of any short distance or small amount of motion whatsoever. The torsometer is a separate little apparatus, a refinement of one devised by the late Prof. W. Voigt for an optical lever mode of

measurement. It is shown in position on the large circular adjusting table of the universal interferometer, where it may be replaced by any other apparatus carrying an object for measurement, or the movement of which is to be measured, for instance, a crystal

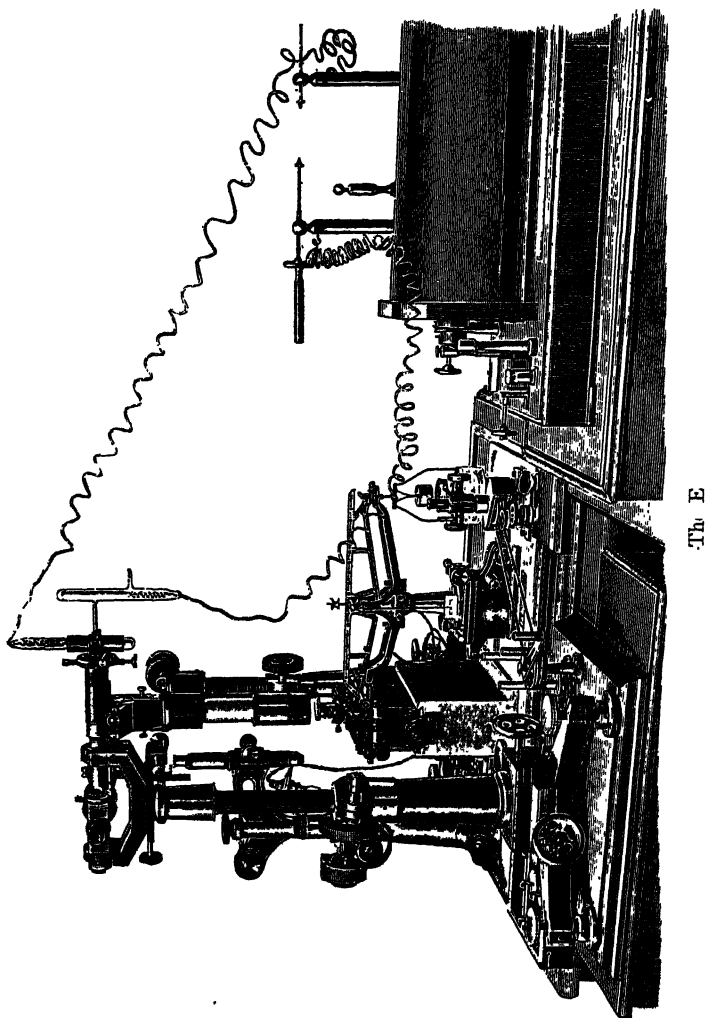
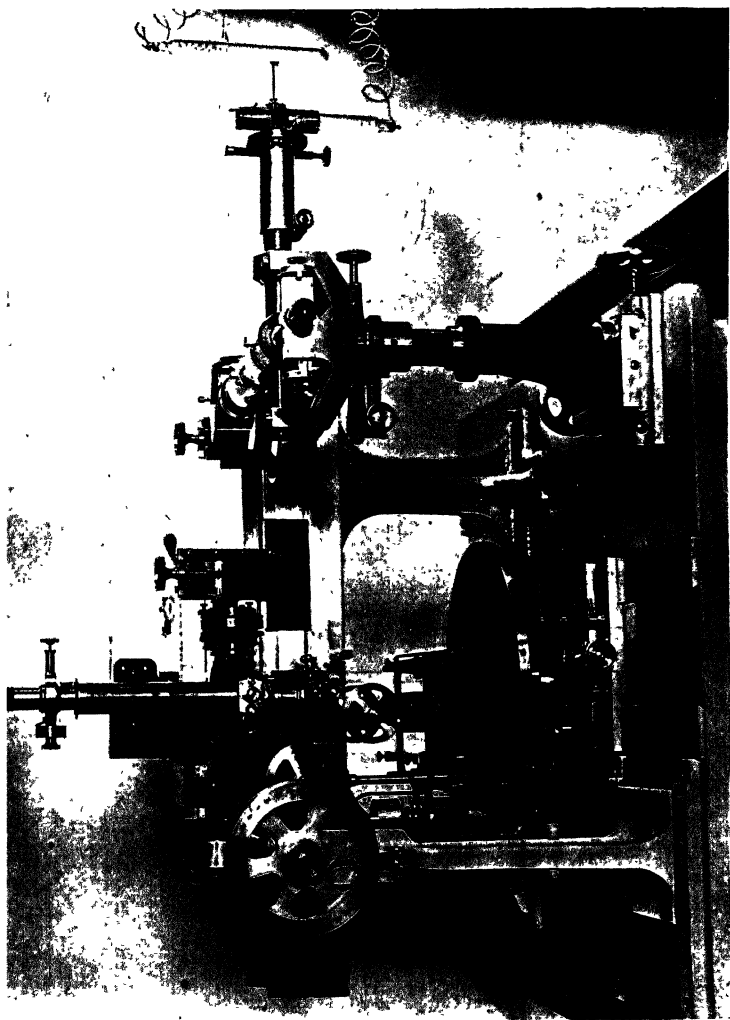

Fig. E

exhibiting piezo-electrical movement. The torsion movement near the two ends of the bar is transmitted by long radial levers to two little counterbalanced and practically frictionless sliders, each of which carries a somewhat remarkable fiducial mark, the movement of which is observed and followed by the microscope which forms



Interferom

Fig.

a prime feature of the universal interferometer, and which actually carries the second reflecting surface of the interference apparatus. This fiducial mark consists of five parallel lines one-forty-thousandth of an inch apart, ruled by the late Prof. Grayson, of Melbourne, the actual fiducial signal being the third (middle) line of the five, as suggested by the author in connection with the standards comparator. With a low power the five lines appear as a single very sharp line, but with a specially constructed Beck one-sixth inch apochromatic objective (which gives considerable working distance) and the second eyepiece, the five lines are beautifully resolved, an apparent millimetre apart, the magnification being about 3000 diameters using a pointolite lamp with condenser and green screen.

The optical apparatus for producing the bands is the same as for the dilatometer and elasmometer, as far as the autocollimating telescope and Geissler tube are concerned. But the whole optical axis is now horizontal, a Hilger constant deviation prism of large size being used on a horizontal rotating table instead of the vertical train of refracting prisms, and the large glass plates, forming the interference apparatus, being now vertically arranged. The travelling microscope, which carries at its side the black glass disc affording the second reflecting surface, is moved, first coarsely over a 30-inch V-and-plane guiding bed, and second with extreme fineness over a V-and-plane bed in its coarsely adjusting block, by means of a highly accurate screw of one-fiftieth inch pitch, the greater portion of the weight of the microscope and carrier being relieved by steel ball-bearing rollers. The control of this excessively fine movement of the microscope is effected by use of the large wheel seen to the left front in the figure. It connects by means of a flexible steel wire-coil shaft to an endless screw, which gears with a worm-wheel of 100 teeth carried by the screw near its outer end. So perfect and delicate is the control that any interference band may be brought to the centre and held there as long as desired, and a considerable proportion of a revolution of the large wheel is required to bring any two bands in succession to the centre. The fine screw finally terminates in a large silvered drum-head, which is divided to read directly to one-thousandth of the pitch, $1/50,000$ inch or $1/2,000$ millimetre. Together with a finely divided silver scale and vernier on the movable block and the guide bed, this enables the most refined mechanical measurements also to be carried out.

Hence this universal interferometer enables measurements to be carried out mechanically, micrometrically, by means of Grayson rulings $1/40,000$ inch apart, or by the interference bands. The rulings can also be calibrated in terms of bands by direct comparison. It is thus an instrument for the finest possible measurement in general.

CHAPTER XX

THE CHEMICAL SIGNIFICANCE OF CRYSTALLOGRAPHY. THE THEORY OF POPE AND BARLOW, OF SOLLAS, AND OF FEDOROV. CRYSTALLO-CHEMICAL ANALYSIS

NOTHING in connection with the subject of crystallography is more surprising than the neglect and apathy with which it had until quite recently been treated by the chemical world. That crystalline structure is intimately related to chemical constitution will have been made abundantly plain during the course of this book. Yet in spite of the great work of Mitscherlich, essentially a chemist, and of a large amount of striking work which has been steadily accumulating during the last thirty years, with results of vital importance to chemistry, and especially of the truly wonderful results of X-ray analysis described in Chapter XII, it is only at the eleventh hour that chemists are really awakening to the vast significance which crystal structure has for them.

The explanation undoubtedly is, that the long interregnum of conflicting investigations, doubt, and controversy which followed the work of Haüy and Mitscherlich, and preceded the beginning of really accurate and painstaking investigation of an organised and systematic character, had caused chemists to regard with more or less of indifference the work of the crystallographers. Added to this we must remember that the subject of crystallography has hitherto been taught, when taught at all, merely as an appanage of mineralogy, although the pure chemical substances (about 8,000 in number) which crystallise well enormously outnumber the naturally occurring minerals, and the results afforded by them frequently possess a much greater value by reason of the purity of the substances and their more definite chemical constitution. Also the mathematical and geometrical side has usually been unduly emphasised, and carried on in lectures without any practical goniometrical work at all. Moreover, the current text-books have often proved forbiddingly full of calculations and formulæ, and of the obsolete and unenticing symbols of Naumann.

At last we have come to see that the subject is one of fascinating interest when its study is commenced in a practical manner from

the beginning, armed from the very first lesson with the goniometer. The actual crystal is then our main and highly interesting study ; its exterior form unravels itself in a most delightfully simple manner when we follow the arrangement of its faces in zones on the goniometer itself ; and its symmetry becomes immediately patent to our eyes in all ordinary simple cases, when we construct for ourselves its plan in a stereographic projection, drawn at first in free-hand while still at the goniometer. The calculations also become perfectly simple when we have learnt that only the simplest of the very easy formulæ of spherical trigonometry are required, and which a knowledge of only elementary plane trigonometry enables us to apply. Aided by a few very helpful rules, such as those of Napier for calculating right-angled spherical triangles, and the rule of the anharmonic ratio of four poles in a zone—which, when the positions of three crystal faces of the zone are known, immediately enables us to calculate the situation of any fourth face of the zone—we have at once a stock-in-trade which carries us over all difficulties in the way of calculation, and relegates this side of the work to an altogether subordinate position, although accuracy in carrying it out is, of course, absolutely essential and even vital. Any readers who should be attracted to pursue the subject further thus practically will find every aid necessary in the author's larger work, *Crystallography and Practical Crystal Measurement* (2nd Edition, 1922, 2 vols., Macmillan and Co.).

Previous to the discovery of Laue, that X-rays were capable of reflection from the planes of atoms in crystals, considerable interest on the part of the chemists had begun to be attracted to the bearing of crystallography on their science by the remarkable theory which had a few years previously been advanced by Sir William Pope and Mr. W. Barlow. This theory connected the internal structure of crystals with chemical valency, the property governing the extent to which the atom of a chemical element is capable of combining with the atoms of other elements, and which is generally expressed by the number of atoms of a monad element, such as hydrogen or chlorine, with which it is capable of combining chemically. Thus the electro-positive metal potassium is said to have monad valency because it is capable of combining with one atom of the electro-negative element chlorine to form the salt potassium chloride, KCl ; calcium possesses dyad valency because it can unite with two atoms of chlorine to form calcium chloride, CaCl_2 ; aluminium is triadic as it can combine with three atoms of chlorine producing aluminium chloride, AlCl_3 ; carbon is a tetrad because it can take up four chlorine atoms, forming carbon tetrachloride, CCl_4 , and phosphorus a pentad as it can fix five with production of phosphorus pentachloride, PCl_5 ;

while sulphur is a hexad because it can take up as many as six atoms of chlorine, forming sulphur hexachloride, $S\text{Cl}_6$.

Occasion has already been taken in Chapter XIV to refer to the able work of Sir William Pope with regard to optically active carbon compounds, and in Chapter X the important contribution of Mr. Barlow to the completion of the theory of the homogeneous partitioning of space has likewise been discussed. In collaboration these two investigators have more recently propounded a theory which connects the chemical and geometrical sides of crystallography in a somewhat startling manner, which naturally aroused very considerable discussion. Although in the sequel the theory has proved to have no basis of fact, as shown conclusively in Chapter XII in connection with X-ray analysis, and has been replaced by the law of atomic diameters, it has had the best results in attracting investigators to the subject, and prepared the way for the coming of the truth.

Starting from the facts which have been laid down in this book as having up to that time been firmly established by the most careful measurement and experimental investigation—notably the constancy of the interfacial angles of the crystals of the same substance, the fixed positions of the atoms or their spheres of influence in the molecule and in the crystal, and the arrangement of the molecules, or small groups of molecules, in space-lattices and the atoms in point-systems—Pope and Barlow assumed that valency, the expression of the relative combining power of the chemical elements, is determinative of the size of the sphere of influence of the atom of an element, and that the relative sizes of such spheres of influence determine the modes in which they can be packed, that is, the nature of the homogeneous crystal structure which they can build up. The theory consequently renders the chemical phenomenon of valency and the physical phenomenon of crystalline form mutually interdependent.

It will thus be apparent that the essence of their conception is that the chemical molecule may be considered as made up of a number of spheres corresponding to, and representing, the spheres of influence of the atoms composing it, and that the volume of each sphere is roughly proportional to the valency of the atom which it represents. They then assumed that the sum of the valencies of the atoms present in the molecule may be substituted for the molecular volume, and the quantity thus arrived at was termed by them the "valency volume." By using the valency volume instead of the molecular volume in the author's formulæ for calculating the molecular or polymolecular distance (topic axial) ratios, which have been shown in Chapter XI to afford the relative dimensions of the unit-cell of the space-lattice, and the distances of

separation of the centres of gravity of the molecules, or groups of molecules, from each other along the directions of the crystal axes, Pope and Barlow arrived at new ratios, which they termed equivalence parameters. By the use of these latter they attempted to account for the crystalline structure of a number of substances—chiefly organic compounds, in the investigation of which Prof. Pope has proved so adept—which are connected morphotropically in the manner described in Chapter IX, and of others which are still less intimately connected.

Unfortunately, the equivalence parameters do not make clear the relationships in an isomorphous series, as do the molecular distance (topic axial) ratios; for they are, from their very nature and mode of derivation, almost identical for all the members of an isomorphous series, the valencies of the interchangeable elements being the same. The molecular distance ratios have also the great advantage of being derived from the three measurements which have now been brought to the highest pitch of experimental accuracy, namely, atomic weight determinations, density determinations by the Retgers immersion method, and goniometrical and physical measurements (optical and thermal) with instruments now available of the utmost refinement. Structural constants thus derived are obviously of especial value. It would thus appear that the theory takes no account of the experimentally proved regular increase in volume and in the directional dimensions of the structural unit cell of the crystal space-lattice, when one element of the same family group and of the same valency is interchanged for another. Indeed, the theory entirely ignores and fails to offer any explanation of the highly important physical property of density, specific gravity. That this physical constant, and the equally important constant molecular volume, derived by dividing the molecular weight by the density, possess a real and significant meaning in isomorphous series, formed by the interchange of elements of the same family group, has been clearly proved in Chapter XI, and confirmed by the results of the X-ray analysis of the rhombic alkali sulphates.

A precise statement of their conception was made by Prof. (now Sir William) Pope in an excellent Report on the Progress of Crystallography, issued by the Chemical Society early in the year 1909. He stated that they (Pope and Barlow) "regard the whole of the volume occupied by a crystalline structure as partitioned out into polyhedra, which lie packed together in such a manner as to fill the whole of that volume without interstices. The polyhedra can be so selected that each represents the habitat of one component atom of the material, and are termed the spheres of atomic influence of the constituent atoms. Up to this point no assumption is made

other than that clearly indicated by the result of crystallographic measurements, namely, that each atom present in a crystalline structure exerts a distinct morphological effect—or, what is the same thing, appropriates a certain definite volume. The assumption is next made that the crystalline structure, which is resolvable into individual molecules and ultimately into individual atoms, exists as such by reason of equilibrium set up between opposing attractive and repulsive forces operating between the component atoms, and that this equilibrium results in the polyhedra representing the spheres of atomic influence assuming shapes which are as nearly as possible spherical. . . . The polyhedra thus arrived at may be regarded as derived by compression of a close-packed assemblage of deformable, incompressible elastic spheres,¹ the compression sufficing for the practical extinction of the interstitial space. When such an assemblage is released from pressure it is evident that in place of polyhedra, the shapes of which approximate as closely as possible to the spherical, closely packed spheres are presented; the distances between the sphere centres can be substantially in the same ratios as the distances between the centres of the corresponding polyhedra in the unexpanded mass, and the equilibrium condition of maximum sphericity of the polyhedra will be presented in the expanded mass of spheres by the existence of the maximum number of contacts between spheres. The whole method of treating the primary assumption thus resolves itself into finding close-packed assemblages of spheres of various sizes representing by their relative volumes the spheres of influence of the component atoms of any particular crystalline structure. The conclusion is that the volumes appropriated by the polyhedra representing the spheres of atomic influence in any crystalline structure are approximately proportional to the numbers representing the valencies of the respective elements concerned.”

Some very interesting evidence apparently, at first sight, bearing on the validity of their fundamental assumption of spheres of influence of the component atoms as the ultimate structural units, was brought forward. They showed that there are two modes of closely packing equal spheres, which give rise respectively to a cubic and to a hexagonal crystal structure, the latter having a specific axial ratio of the vertical to the three equal equatorial horizontal axes; and that the chemical elements which are solids and crystallise, and the structural units of which can naturally be assumed to be equal spheres, being those of the similar atoms of

¹ This apparent contradiction in terms the author takes to mean that, whatever compression is produced by pressure on one part of the sphere, is counterbalanced by a corresponding protuberance produced in the part not confined under pressure, the total volume being incompressible.

the same chemical element, do practically all crystallise either in the cubic system or in the hexagonal system with the specific axial ratio just referred to. But the theory as it concerns chemical valency is in reality not at all affected by these interesting facts, as the spheres of influence present are those of the identically similar atoms of the same element, and the atomic volume therefore is the same throughout. But when the theory proceeds to assign to the atomic spheres of influence, in the case of different elements, relative volumes proportional to their chemical valencies, it propounds a highly improbable speculation. If true, it would mean, for instance, that in the alkali sulphates, K_2SO_4 , Rb_2SO_4 , Cs_2SO_4 , $(NH_4)_2SO_4$, while the volume of the spheres of influence of the potassium, rubidium, and caesium atoms were all of volume 1 (corresponding to monad valency), although we pass from an element (potassium) of atomic complexity represented by the atomic number 19 to the much more complex atoms of caesium of atomic number as high as 55, the volume of the spheres of influence of oxygen would be 2 (corresponding to dyad valency), double that of the caesium, although the atomic complexity of oxygen is only represented by the low atomic number 7, one-eighth of that of caesium.

The author has met with some very definite evidence, which is directly opposed to the Barlow-Pope theory of valency volumes, in the course of his researches on the rhombic sulphates and selenates of the alkali bases just referred to (the series R_2SO_4) and the monoclinic double sulphates and selenates (the series $R_2M(S_{Se}O_4)_2 \cdot 6H_2O$).

It concerns the isostructure of the ammonium and rubidium salts of any group of these salts, and has already been referred to on page 105 and in Chapter XII, page 129. The volumes and linear dimensions of the space-lattice unit cells of the crystals of these ammonium and rubidium analogous salts were shown to be practically identical. But according to the valency volume theory, the volume of the unit cell of ammonium sulphate should be double that of rubidium sulphate, for there are 24 valency volumes in $(NH_4)_2SO_4$ and 12 in Rb_2SO_4 , counting 1 for each atom of Rb or H, 2 for each atom of O or S, and 3 for each N atom. If N be 5 (pentadic) the volume of the ammonium salt would be still more than double that of the rubidium salt.

There is ample additional proof, from the ready formation of mixed crystals and overgrowths, that the crystals of the ammonium and rubidium salts are truly isostructural, and the fact has been finally clinched as absolutely proved by the X-ray analysis of the alkali sulphates in the laboratory of Sir William Bragg, by Prof. Ogg and Mr. F. L. Hopwood, whose absolute measurements of the

sizes of the space-lattice cells have remarkably confirmed the author's relative measures, the topic axial ratios, as recorded in Chapter XII.

Moreover, the whole progress of our knowledge of the structure of the atom, and especially the discovery that valency is determined by the number of exterior valency electrons contained in the outer shell of electrons surrounding the atomic nucleus, is against the valency volume theory. The latter is also diametrically opposed to the results of important researches by Prof. Richards, of Harvard University, on the compressibility of atoms. These facts, and many others in confirmation, were all set forth by the author in a special memoir¹ on the subject to the Royal Society in the year 1917, and there the matter rested until the year 1920, when Prof. W. L. Bragg published his law of atomic diameters, as the result of a complete survey of all the X-ray analyses of crystals then accumulated, as described in Chapter XII. The idea that the size of the sphere of influence of the atom, the atomic domain, which is probably that of the outer shell of electrons, dominates crystal structure has proved to have been sound. But the size is not proportional to or in any way governed by the valency of the element, but rather the reverse, for the monad alkali metals are the largest, occupying the maxima of the curve of atomic diameter. It is, indeed, not the number of the valency electrons in the outer shell which governs the atomic diameter, but the dimensions of the outer shell itself, as represented by the diameter given in the table and curve of W. L. Bragg, and as determined by direct measurement by means of X-rays in the crystal structures containing the atoms.

Moreover, it must be remembered that yet another view, and one which was not far from the truth, that of Sollas,² was put forward in the year 1898, that the packing of the molecules is a more open one altogether, a view to which he had been guided by consideration of the molecular volume. Sollas offered some remarkable explanations of crystal structure, notably in the case of the dimorphous forms of silver iodide. The abnormal contraction which occurs on heating this interesting substance, and its sudden transformation at 146° from the ordinary hexagonal into a cubic modification as discovered by Lehmann, appear capable of very clear explanation on the basis of his theory. According to this theory of Sollas the volumes of the spheres of influence of the atoms of the different elements of the same family group, such as those of the group of alkali metals or those of the halogens, chlorine, bromine, and iodine, vary progressively in a manner which is dependent on the

¹ *Roy. Soc. Proc., A*, 1917, **93**, 72.

² *Proc. Roy. Soc.*, 1898, **63**, 270, 286, and 296; 1901, **67**, 493.

atomic volumes of the elements, as given in the celebrated curve of Lothar Meyer, which have a real comparative significance when the elements belong to the same family group.

Moreover, it is significant that in the thoroughly well-investigated case of the diamond referred to in Chapter XII, the spheres of influence of the carbon atoms are not closely packed, as revealed by the X-ray analysis, but are regular tetrahedra so modified by the rhombic dodecahedron that each tetrahedral face is a regular hexagon. The assemblage of such structural units is not and cannot be a closely packed one. The views of Sollas are thus to this extent confirmed by the use of the powerful new instrument of research, the X-ray spectrometer.

The curve of atomic diameters of W. L. Bragg is very similar in general aspect to that of Lothar Meyer, the alkali metals occupying the periodic maxima of both curves, but the intermediate details differ somewhat considerably. Still, Sollas was very much nearer the truth than Pope and Barlow, and the time has come when he should have the credit due to his prescient suggestion.

Moreover, Fedorov has developed his particular theory in a very masterly manner, and with the aid of it professed, and with very considerable success in many cases, to determine the correct mode of setting up a crystal for truly comparative descriptive purposes, and derived therefrom a remarkable method of crystallochemical analysis. Fedorov, whose loss during the troubles in Russia is so deplorable, also developed his theory on lines which are not far from the truth, for his parallelohedra were supposed to have volumes proportional to the molecular volumes.

He has reviewed the whole available experimental crystallographic data for the eight thousand substances the crystals of which have been measured, and in many doubtful cases has made new measurements. The results have been gathered into a remarkable table, in which the crystallographic characters of each, needful for the recognition of the substance, are expressed in a concise symbol or crystallographic label. To the initiated this mystic symbol conveys a remarkable amount of information as to the symmetry, crystal elements and constants of the substance, adequate, in fact, to enable the identification of the substance to be made by anyone versed in the method of Fedorov.

The essence of his theory and method is that the space occupied by the substance in the crystalline solid condition is filled with one of the four parallelohedra which alone are capable of completely occupying space by their contact repetition, namely, the cube *a*, in Fig. 166, the hexagonal prism *b*, the rhombic dodecahedron *c*, and *e* the cubo-octahedron (the orthic tetrakai-decahedron of Lord Kelvin); there is a fifth possible, the elongated dodecahe-

dron, d , but for crystallographic purposes this is an indistinguishable variety of the rhombic dodecahedron. These parallelohedra are shown in Fig. 166.

There are only two types, however, for all but the hexagonal prism are of cubic type, so that Fedorov eventually distinguishes two principle types of crystal structure, cubic and hypohexagonal. Moreover, the parallelohedra may be homogeneously deformed into parallelohedra of tetragonal, orthorhombic, monoclinic, or triclinic symmetry, while still filling space. Hence, the two types may be more generally called tetragonaloid and hexagonaloid. By replacing the parallelohedra by representative points, Fedorov derives 22 point-systems, which reduce to 14 as some prove to be identical. These are the 14 space-lattices of Bravais. The distances between the representative points are the molecular distance (or topic axial) ratios, as the volume of the parallelohedron is taken to be proportional to the molecular volume.

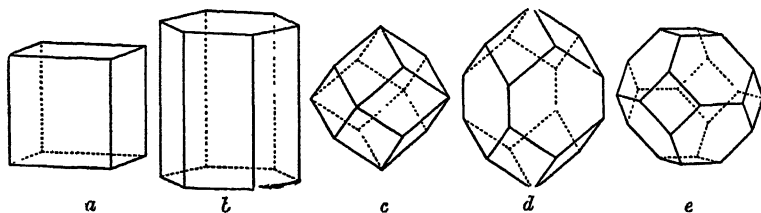

FIG. 166.—The Five Parallelohedra of Fedorov.

He then derives the correct setting of the crystal, that is, which directions respectively shall be those of the back-to-front a -axis, the lateral b -axis, and the vertical c -axis, by consideration of the type (whether hexagonaloid or tetragonaloid), and of the reticular density of the principal faces; for it has been well established that the fundamental (primary) faces are those in which the points of the space-lattice are most densely massed. Cleavage is here a great help to him, as naturally these closely bestrewn planes are those of maximum cohesion.

Having thus decided on the type of crystal and its correct setting, Fedorov expresses his results in his "complex symbol" already referred to. This expression indicates simultaneously the type of structure and the characteristic angles, and occupies less than a square inch of written or printed space. Whether it will come into general use is doubtful, especially since the premature death of this great thinker and hard worker as a victim of the Russian Revolution. It should not be difficult to adapt the theory to the Bragg law of atomic diameters instead of molecular and atomic volumes, which are only strictly comparable for members of the

some isomorphous series; and to this extent both Sollas and Fedorov are not wide of the mark. It is, at any rate, most satisfactory to learn that *The Crystal-Kingdom*, which embodies Fedorov's great table, has just been published, practically in the form in which he left it. The total number of substances actually included in it, as having been adequately measured, is 7400. That it must be of considerable value is proved by the interesting fact that in the year 1912 some stringent tests were made, the crystals of a number of substances measured by well-known experts having been sent to Russia to Prof. Fedorov, with only an identification number on the bottle in which each substance was contained, and in practically every case the substance was identified by Prof. Fedorov. The author himself submitted quite a number of such specimens, and all but one were definitely and correctly diagnosed, the exception even being one which was identified as belonging to a particular isomorphous series of salts, the members of which were very closely similar.

Thus it is quite possible, owing to the truth of the law of Haüy, so fully discussed in Chapters III, VIII and XI, to recognise and identify a solid substance entirely by its crystallographic morphology. When we add to this the knowledge derived from an optical study of the substance the identification becomes even more easy, complete, and certain.

CHAPTER XXI

CONCLUSION

ONE of the compensating results of the Great War has been to bring about a much deeper interest in science, and to fill our universities with young men keen to learn all that is to be known, and to assist in the acquirement of further knowledge. It is to be hoped that many will be attracted to this rapidly growing branch of science, the importance of which to chemistry and physics is increasing every day. Our country has, in this science at any rate, a fine record, having with few breaks led the van of progress from the time of Wollaston, the inventor in the year 1809 of the reflecting goniometer and the real discoverer of isomorphism, and of Miller, the originator in 1839 of our method of describing crystals and the pioneer of accurate experimental work, down to the present day. It may be, also, that our country's reputation is safe at this moment.

For when we look backwards to the time when Sir William Crookes was exhibiting the first of his famous tubes in which electrons are generated, we cannot fail to appreciate the fact that the research which he then initiated, concerning the passage of the electric current through high *vacua*, laid the foundation for the unravelling of the marvellous story of the constitution and complex nature of the chemical atom of Dalton, for the discovery of X-rays (which he had been himself using for several years) by Röntgen, of radioactivity by Becquerel, and of radium itself by the Curies. Moreover, the discovery of the inert gases of the atmosphere by Lord Rayleigh and Sir William Ramsay, so highly important as an aid to the elucidation of atomic structure; the prolonged experiments in the further elucidation of that structure carried out in the Cavendish Laboratory at Cambridge by Sir Joseph Thomson; the brilliant and conclusive work of Moseley (so unhappily cut off by the fell demon of war at Suvla Bay, Dardanelles, in the year 1915), in settling the main structure of the atom, and showing its progressive evolution in accordance with the atomic number; the steady contribution in the same direction by Sir Ernest Rutherford, and especially his recent fundamental achievement in the disintegration of atoms by bombardment with helium α -particles; and

lastly, the marvellous manner in which the immense new field of crystallographic structure-analysis by means of X-rays has been expanded, after the initial discovery of Laue, by Sir William Bragg and his son, Prof. W. L. Bragg, and especially its consummation in the law of atomic diameters, all give ground for just pride that this immense progress in natural knowledge has been so largely contributed by our own countrymen.

The mere recital, above given, of just a few of the outstanding events in this progress must have called attention to the intimate and indissoluble connection between physics, chemistry, and crystallography, and to the interdependent character of these branches of study. Indeed, crystallography is no longer merely the science of crystals: it is the science of matter in general as well as of solid matter in its most perfectly developed and organised form. Its study in the past has been in the hands of a band of investigators so small, and often of the private and not professional nature, carrying on the work for sheer love of it and deep interest in it, that the wonder is that so much has been done. But now there is every reason to hope that the brilliant successes recently achieved, and the much more powerful means of experimental attack now open to us, together with the great increase in the number of workers which these famous researches have attracted, will ensure that our national tradition of leadership in crystallography shall, in the future, not only be ably maintained, but rendered even more striking and complete.

If the perusal of this book should have awakened sufficient interest in the minds of some of its readers to prompt them to offer themselves as recruits to this band of investigators, and especially if it should have inspired the zeal and enthusiasm of a few of those keen spirits who are looking around for a promising and fascinating field of work, and, finally, if it should prove to be of assistance in obtaining the means of training such recruits with the help of the best and most accurate experimental apparatus which can be obtained, the author's main objects in writing it will have been attained.

APPENDIX I

GLOSSARY OF TECHNICAL TERMS

Allotropy.—The occurrence of the same chemical element in two or more forms, which are different not merely physically but chemically, owing to the molecule being composed of a different number of atoms and acting as a different entity in the two cases. The best understood instance is oxygen and its allotrope, ozone, which latter has three atoms of oxygen to the molecule, O_3 , instead of two as in ordinary gaseous oxygen, O_2 .

Crystal Angles.—The interfacial angles are generally meant. The angle referred to as the interfacial angle (that between two crystal faces) is generally that between the normals to the faces, which is actually measured on the reflecting goniometer, and is that angle through which the circle and with it the crystal are rotated, from the position when the signal-image of the collimator reflected from one of the faces is adjusted to the cross-wires of the telescope, to the position when the image from the other face is similarly so adjusted. It is the supplement of the dihedral angle between the two faces. (See page 55.)

Anisotropic.—The property possessed by substances belonging to systems of symmetry other than the cubic, of exhibiting different optical characters in different directions within the crystal, including especially the property of double refraction. (See term *Isotropic*, also pages 169 to 174.)

Optical Antipodes.—The two varieties of an enantiomorphous (see this term) substance, which rotate the plane of polarisation of polarised light to the same extent to the right and left respectively.

Asymmetric Atom.—An atom of a chemical element of at least tetravalency, in combination with other atoms to form a chemical compound, in such a manner that the atom or a different element or radicle group of elements is attached to each of the valency "bonds" of the atom in question. Carbon compounds afford the best and most numerous examples, but asymmetric atoms of nitrogen, silicon, tin, phosphorus and other elements are known. In general, when such an atom is present the compound exhibits optical activity in two enantiomorphous antipodes, right and left-handed. It is not, however, the absolutely essential condition for optical activity in two antipodes, the absence of a plane of symmetry or other second order symmetry element being the imperative condition. (See term *Symmetry Elements*, also page 156.)

Crystal Axes.—The systematic axes, three in all systems but the hexagonal, and four in the latter system, about which the crystal is imagined to be constructed. They are parallel to the edges of intersection of the three (or four) important faces chosen as the axial planes. They are mutually rectangular in the cubic, tetragonal, and rhombic systems. The crystal axes are not necessarily axes of symmetry, although in the more symmetrical systems and classes they are so. (See page 34.)

Optic Axis or Axes.—The direction of no double refraction in a uniaxial crystal (see this term), identical with the single tetragonal, hexagonal, or trigonal axis of symmetry of these three crystal systems. Or the pair of (more or less) corresponding directions in a biaxial crystal (see next paragraph); these are the two directions at right angles to the two circular sections of the ellipsoid which represents the optical properties of a crystal belonging to the rhombic, monoclinic, or triclinic system.

Biaxial.—An optical term referring to the less symmetrical of the two great types of doubly refractive crystals, namely, those belonging to the rhombic, monoclinic, and triclinic systems. The optical ellipsoid for this type is the general one with three unequal rectangular axes, corresponding in their relative lengths to the three indices of refraction, α , β , and γ . The plane of the ellipsoid containing the minimum and maximum axes α and γ contains two symmetrical directions equal to the intermediate axis β normal to the plane, and the two planes containing them and β thus make two circular sections of the ellipsoid, perpendicular to which there is no double refraction. These two directions normal to the circular sections are thus of the nature of optic axes, and the crystal is therefore said to be optically biaxial. The cases are not, however, in their ultimate details quite like the simpler one of the single optic axis of uniaxial crystals. In convergent polarised light between crossed Nicols the interference figure afforded is a very characteristic one, when a plate of a biaxial crystal is examined which has been cut perpendicularly to the bisectrix (the First Median Line) of the acute angle between the optic axes. The two positions where the optic axes emerge are marked by spectrum rings centred around them, and the vertices of dark hyperbolic "brushes" passing through them. The rings are not circles, however, but curves known as lemniscates, and after the first apparently concentric few they pass first into figure-of-eight looped lemniscates (one loop round each axis), and subsequently into ellipse-like outer ones, enveloping both axes, which appear as if they were at the foci. As the crystal is rotated in its own plane the lemniscates remain the same, but the dark brushes revolve around their optic axial vertices, and when the line joining the optic axes is parallel to a direction of vibration of either of the Nicols, the two brushes form a black cross, one darker bar passing through both axes and the other broader one crossing it at right angles midway between the axes. (See pages 183–187 and Figs. 116 and 117.)

Biquartz.—A circular quartz plate, one-half of which (on one side of a diameter) is composed of right-handed quartz, and the other half of left-handed quartz, the two semicircular parts being cemented together by Canada balsam. The thickness is either 7·5 or 3·75 millimetres, as these thicknesses afford the transition tint (violet tint of passage) when the plates are placed in the polariscope between crossed Nicols and parallel Nicols respectively. (See term Transition Tint, also pages 181 and 199 and Fig. 129.)

Cleavage Plane or *Planes*.—A plane at right angles to a direction of minimum cohesion is generally a plane along which a crystal cleaves readily, on the insertion of a knife blade, aided usually by a smart blow with a light hammer. When the cleavage is of the more facile kind known as "perfect" the cleaved surfaces are as true planes as good crystal faces, yielding excellent images of a goniometer signal.

Coincidence Movements.—A coincidence movement is a space-operation of mathematical geometry, which causes the assemblage or system under discussion (of points for instance, or of atoms, or the whole crystal itself) to be brought to appear exactly the same as before the movement was commenced. (See term Symmetry Elements and Operations.)

Crossed-Axial-Plane Dispersion.—The phenomenon presented when the optic axes of a biaxial crystal are so differently situated (dispersed) for different wave-lengths of light or degrees of temperature that they are separated in one plane for one extreme colour (wave-length) of light or degree of temperature, and in a perpendicular plane for the other end of the spectrum or extreme of temperature. (See pages 73 and 83, and Plate XV, Fig. 63.)

Crystal Classes.—There are 32 classes of crystals, each class having its own specific elements of symmetry. They are distributed among the seven systems in a manner which will be clear from the list given in Appendix II, in which the elements of symmetry present in each class are specified and an actual example is quoted.

Dichroism and *Polychroism*.—The property which many coloured crystals possess of exhibiting different colours in directions having different relations to the crystal symmetry, owing to the varied amount of absorption suffered by light of the different wave-lengths in different crystal directions. When the crystals are doubly refractive, the two rays travelling through the crystal with different velocities and vibrating parallel to different directions will in general be differently coloured, and if each in turn be extinguished by a Nicol prism the colour of the other can be studied alone. Or both colours may be examined side by side by use of the dichroscope, the essential parts of which are a square aperture, a lens, and a rhomb of Iceland spar, which affords two images of the aperture, each illuminated by one of the rays only.

Diffraction (spectra and patterns).—Optical phenomena including interference fringes due to the bending of the very minute light waves round sharp edges or on passage through very small sharp apertures.

The diffraction grating consists of a very large number (14,000 to the inch in the best Rowland gratings) of parallel lines ruled by a diamond point on speculum metal, and affords a magnificent spectrum for spectroscopic purposes, the light being concentrated in one order of the several orders produced. Casts of Rowland gratings in transparent celluloid also serve well.

Dimorphism and Polymorphism.—The property possessed by one and the same chemical substance of crystallising in two or more definitely different crystalline forms. Each form is distinguished by its own temperature limits, so that one of the forms only is truly stable at the ordinary temperature. (See Chapter XIII.)

Dispersion.—Variation of an optical property for the different wave-lengths of light. The most frequent use relates to refraction, dispersion in this sense meaning the length of the spectrum, corresponding to the variation of the refractive index between the extreme red (longest waves) and furthest violet (shortest waves). Another frequent use is to indicate the variation in position of the optic axes of a biaxial crystal for the two extremes of the spectrum.

Double Refraction.—The property possessed by crystals of other than cubic symmetry of causing a ray of light transmitted by them in general to be separated into two rays vibrating (plane polarised) in two mutually perpendicular planes. A 60°-prism cut out of a non-cubic crystal thus in general affords two spectra, instead of the single one which would be given if the prism were of glass, or were cut from a cubic crystal. Exceptional directions of single and not double refraction, however, are (1) those of the tetragonal, hexagonal or trigonal axes of the three systems bearing the names of these axes, which are therefore termed optically uniaxial systems; and (2) the two normals to the two circular sections of the optical ellipsoids of rhombic, monoclinic, and triclinic crystals, which are consequently known as the optically biaxial systems. (See terms Uniaxial and Biaxial.)

Electron.—The unit or particle of negative electricity, the “corpuscle” of the cathode rays of a Crookes vacuum tube, and of the β -rays from radium. The chemical atom of an element is composed of a definite number of electrons, disposed in a regular manner, cycles or shells, around a positively electrified nucleus; the number has been shown by Moseley to be equal to the “atomic number,” the sequence number of the element in the periodic classification. The electron, or electrons, of the outer shell appear to act as “valency electrons,” that is, as the actual representatives of the valency “bonds,” or number of unit combining attachments, determining the chemical combining power of the element (with how many of the monovalent chlorine atoms, for instance, it can combine). The different modes in which the outer electrons may act in effecting chemical combination are described in Chapter X.

Optical Ellipsoid.—An ellipsoid representing graphically to scale the optical properties of a crystal. Several types are in use in theoretical optics, but the best and simplest is that of Sir Lazarus Fletcher,

known as the "Indicatrix," the *radii vectores* (from the centre) of which accurately represent the relative values of the refractive index in different directions within the crystal. Thus, in the case of a rhombic, monoclinic, or triclinic crystal, the three rectangular principal axes are proportional to the three refractive indices, α , β , γ , while in the case of a tetragonal, hexagonal, or trigonal crystal, for which the ellipsoid is one of revolution, the semi-principal axis is proportional to the refractive index ϵ , and the radius of the equatorial circular section of the ellipsoid is proportional to the index ω . The Fletcher indicatrix is the polar reciprocal of the Fresnel vibration velocity ellipsoid.

Enantiomorphism.—The property of exhibiting two complementary forms which are the right and left-handed mirror-images of each other. It is a property exhibited only by the eleven classes of crystal symmetry which possess no plane of symmetry. (See Chapter XIV.)

Etched Figures.—The figures (depressions) produced on crystal faces by the action of a solvent on the crystal substance for a limited period of time. These figures usually take very definite and characteristic shapes which indicate the nature of the symmetry of the crystal, and are often of great use in determining to which particular class of a system the crystal belongs.

Extinction Directions.—When a more or less tabular doubly refractive crystal, that is, one not of cubic symmetry, or a plate cut from such a crystal, is rotated in its own plane in the dark field of the polariscope (see that term), using a parallel beam of light, it generally (that is, unless the plate be perpendicular to an optic axis) appears four times bright and possibly coloured, and four times dark, during a complete revolution of the plate, maximum light and maximum darkness occurring at positions 45° apart. The mutually rectangular positions of maximum darkness are known as the "extinction" positions, and bear a definite relation to the symmetry, as can very readily be determined. For as they are identical with the known planes of vibration of the Nicols of the polariscope (or of the polarising microscope), which are made beforehand to correspond to the 0° and 90° readings of the graduated circle and with the cross-wires of the eyepiece used, the extinction positions can be compared in angular measure with the directions of particular edges or facial planes of the crystal, which may be brought by rotation of the circle (with which the crystal moves) to parallelism with one of the cross-wires. In the more symmetrical systems, for instance, the extinction directions are parallel to the crystal axes (and edges parallel thereto), when the plate is one parallel to a primary pinakoid or the basal plane, or to a face of the primary zone. (See pages 177 and 195.)

Faces, Primary and Secondary.—The primary crystal faces are those which are parallel to one or other of the axial planes (and therefore to two crystal axes), such as (001), (100), and (010), or which are parallel to one crystal axis and involve only unit intercepts on the other axes, such as (110), (011), and (101), and the parametral form

faces typified by (111). All other faces, involving any (even one) except unit intercepts and indices and cipher indices, are secondary faces, even although in relative development they may predominate.

Form.—In its technical crystallographic sense a “form” is a face or group of faces having an equal value relative to the symmetry, the same integral numbers (including a cipher or ciphers possibly) appearing in the symbols of all the faces of the form, although the order of the numbers may vary. For instance, an octahedron is a cubic form composed of eight faces all having unit indices such as (111), the variation being shown by negative signs over such indices as refer to interception by the face on the negative half of an axis, to the left or back of the centre or below it. A hexakis octahedron is a form of the same highly symmetrical system comprising no less than 48 faces, all having the same three integers, for example (321), in their symbols. On the other hand, the orthodomal forms of the monoclinic system, as well as the pinakoid forms of both this and the rhombic systems, possess only two faces to the form, and in class 1 of the triclinic system every face is a form unto itself, on account of the lack of symmetry. Brackets of the doubly curved kind are used to distinguish a form symbol, thus that of the commonest hexakis octahedron is {321}.

Germ Crystals.—Excessively minute crystals, estimated at only 10^{-9} to 10^{-12} gramme in weight, are always floating about in the air, either as miniature perfect crystals, or crystallites, or crystal particles, and are responsible for the crystallisation of solutions in the particular intermediate state of supersaturation known as metastable, into which solutions these crystal germs fall. (See Saturated and Super-saturated Solutions; also page 44 and Fig. 47.)

Habit.—The general shape and appearance of a crystal. Types of habit are such as the following: Tabular, prismatic, pyramidal, short prismatic, more or less spherically polyhedral, laminar, flaky, needle-shaped or acicular. Often the predominating form is said to confer the habit; for example, the crystal may be stated to be of octahedral or rhombohedral habit.

Hemihedral.—An obsolete term denoting the crystal classes in which only half the number of faces belonging to certain “forms” of the highest class of the system are present. This is not due, as was formerly supposed, to the suppression of the other half of the faces, but to the characteristic absence in the lower class in question of an element of symmetry operative in the highest class of the system.

Hemimorphic.—When a crystal is differently terminated (by different facial “forms”) at the two ends of an axis of symmetry or crystal axis, owing to the absence of a plane of symmetry perpendicular to the axis, it is said to be “hemimorphic.” The axis in question is also said to be “polar.”

Holohedral.—Having the full number of faces corresponding to the development of the complete maximum symmetry possible to the crystal system in question. Although this term was coined at the

same time as "hemihedral" and "tetartohedral," two terms now obsolete, it is very convenient to retain the term holohedral, and its retention controverts no point of the modern theory of crystal structure, which regards it as dependent entirely on elements of symmetry present and not on any suppression of a half or a quarter of the holohedral faces.

Homogeneous structure.—In general terms a structure such that the condition about any one point in the structure is the same as about every other point. Another definition, due to W. Barlow, is that "a homogeneous structure is one every point within which, if we regard the structure as without boundaries, has corresponding to it an infinitude of other points whose situations in the structure are precisely similar." In Barlow's sense there are 230 different homogeneous structures possible as crystals.

Index of Refraction.—The number representing the relative bending which a ray of light undergoes on passing from the air (or a vacuum) into the denser medium of the substance in question. It represents the ratio of the velocity of light in air to that within the substance and is afforded by taking the ratio of the sines of the two angles of incidence and refraction. Thus if μ be the index of refraction, θ the angle of incidence on the plane surface of the transparent substance, and ϕ the angle of refraction within it, both angles being measured from the normal to the surface, then: $\mu = \frac{\sin \theta}{\sin \phi}$. The refractive index of the diamond for sodium light and the temperature 20° C. is 2.467, while that of glass (light crown) is only 1.515.

Indices.—Besides refractive indices, crystals have very important morphological indices, namely, the figures placed within brackets used to designate and symbolise a face or a form or a zone, and, in the case of a face, to indicate concisely its position on the crystal. The mode of arriving at them is described on page 39, and the following pages. The system devised by Prof. Miller, of Cambridge, in 1839, is now practically universally employed, in which the index-numbers are inversely proportional to the intercepts made by the face on the crystal axes. If the symbol of indices refers to a face the brackets used are of ordinary type, thus (321), which represents the nearest front right face of the hexakis octahedron. If a form is intended, the brackets are of the doubly curved type, thus {321}, which represents the whole hexakis octahedron of 48 faces. If a zone be intended, square brackets are used, thus [012]. To obtain the indices of a zone, the indices of two faces (not parallel ones) in it are combined by cross multiplication.

Intercepts.—These are the relative lengths cut off from the crystal axes by the crystal faces; the numbers in any particular case express in the lowest terms how many times the unit axial lengths, a , b , c , are contained in the lengths along those axes intercepted by the face in question. The face-symbols of Weiss are composed of the intercepts, and are written $ma : nb : rc$. (See page 39.)

Isogonism.—The exhibition of similar interfacial angles in one or more zones of the crystals of two different substances, but not along every zone. When every zone is similar isogonism becomes isomorphism. (See Chapter IX.)

Isomerism.—From *ἰσομερής* consisting of equal parts. The occurrence of two quite different substances having the same empirical chemical composition, that is, the same number of atoms of the same chemical elements in its molecule. The two substances differ in constitution (mode of combination and linkage of the various atoms), and possess quite different characteristics and chemical and physical properties. Thus there are two iodides of the composition, C_3H_7I , namely, propyl iodide, a liquid of specific gravity 1.743 and boiling at $102^\circ C.$, and isopropyl iodide, a quite different liquid substance of specific gravity 1.703 and boiling at 90° .

Isomorphism.—From *ἴσος*, equal to, and *μορφή*, shaped. The occurrence of two or more substances of similar chemical constitution in crystalline forms which are so similar that they only differ slightly in the actual value of their interfacial angles, the crystal system and class and the "forms" developed being the same. The variation of the angles does not exceed 3° , and is generally only one of minutes; it is the less the higher the degree of symmetry, until for the cubic system there is no variation at all, the angles being determined by the symmetry itself. In the cases most thoroughly investigated the angular change follows the order of progression of the atomic weights and atomic numbers of the interchangeable elements of the same family group which, by their replacement of one another in the substance, form the series. (See Chapter XI.)

Isotropic.—Substances such as glass, having similar optical properties in all directions, are said to be "isotropic," from *ἴσος*, equal, and *τροπος*, way, manner. For instance, they are singly refractive and the index of refraction is the same in every direction, assuming the substance to be homogeneous as regards composition and mechanical equilibrium. Strain, due to lack of proper annealing, or purposely sudden cooling, is almost invariably accompanied by optical effect, however, such as the display of polarisation colours in the dark field of the polariscope and double refraction. As regards crystals, only those belonging to the cubic system of symmetry are isotropic. Those of all other systems are said to be "anisotropic," and exhibit double refraction in characteristic ways.

Minimum Deviation.—The bending of a ray of light by a triangular transparent prism of about 60° refracting angle occurs to the minimum extent when the ray, which enters at one face and emerges from a second face, in its passage through the prism follows the direction parallel to the third face and to the base of the prism (assuming the section to be equilateral or isosceles), that is, normal to the plane bisecting the prism angle and containing the refracting edge. The light is then incident on the receiving face and refracted from the exit face at equal angles. This position can easily be found experimentally, as the

refracted image of the spectroscope slit seen in the telescope is then as near to the direct reading (along the axis of the collimator) of the slit as it can be brought. If α be the angle of the prism (near 60° as a rule), and δ the angle of minimum deviation thus found, the refractive index μ is at once afforded by the formula :

$$\mu = \frac{\sin \frac{\alpha + \delta}{2}}{\sin \frac{\alpha}{2}}$$

Molecular Volume.—The quotient of the molecular weight M (obtained by adding together the atomic weights of the elements contained in the compound, each multiplied by the number of atoms of that element if more than one be present) by the specific gravity (density) d of the substance, that is, $V = \frac{M}{d}$. In the case of crystallised substances the density is determined for the standard temperature of 20° C., and as compared with water at its maximum density of 4° .

Molecular Distance Ratios or *Topic Axial Ratios.*—Obtained by combining the molecular volume V with the crystallographic axial ratios, a , b , c . They are denoted by χ , ψ , ω , and are intended to represent the directional dimensions of the unit space-lattice cells the volume of which is represented by V . As the crystals of isomorphous series of substances are built up on the same structural plan these ratios do actually in these truly comparable cases represent the relative dimensions of the unit cells for the various members of the series. As an example of the formulæ from which they are calculated, those for the rhombic system are :

$$\chi = \sqrt[3]{\frac{a^2 V}{c}}, \quad \psi = \sqrt[3]{\frac{V}{ac}}, \quad \omega = \sqrt[3]{\frac{c^2 V}{a}}$$

Morphotropy.—The same as Isogonism (see the latter).

Newton's Rings and *Seven Spectral Orders.*—These spectrum-coloured concentric rings are obtained by pressing two glass surfaces closely together, best when one of the two surfaces is plane and the other is (or is made by the pressure) slightly convex; they are due to interference of the rays reflected from the two surfaces (plane and convex), the air film between which is of regularly varying thickness, affording a graduated difference of length of path, from zero at the centre where the plates touch. The order of the colours is: First (central) ring, black (central spot), blue, white, yellow, red; second ring, violet, blue, green, yellow, red; third ring, purple, blue, green, yellow, red; fourth ring, green, red; fifth ring, greenish-blue, red; sixth ring, greenish-blue, pale red; seventh ring, greenish-blue, reddish-white. Beyond the seventh ring, owing to overlapping, we have "whites of the higher orders," then, pure white light. If instead of ordinary white light monochromatic light be employed, many more rings than seven are seen.

Nicol Prism.—A rhomb of Iceland spar (rhombohedral form of calcite, CaCO_3) is cut in two along a particular diagonal plane and the two parts cemented together again with a film of Canada balsam. The effect is to permit only the extraordinary ray to be transmitted, of the two rays (ordinary and extraordinary) into which a beam of light entering the rhomb is divided, the ordinary ray being totally reflected at the balsam film, away to the side, where it is absorbed by the blackened metallic case in which the prism is mounted. Thus from a "Nicol" there is transmitted a beam of pure plane-polarised light; for the extraordinary ray which escapes is composed entirely of vibrations parallel to the principal section of the crystal, that is, to the plane containing the optic axis (calcite being optically uniaxial), the shorter diagonal of the rhombic end-face, and the two long edges of the rhomb terminating at the ends of the shorter diagonal. (See page 184 and Fig. 114.)

Optic Axial Plane.—The plane containing the two optic axes of a biaxial crystal. The two bisectrices of the acute and obtuse angles between the optic axes, also lying in the plane, are known respectively as the *First* and *Second Median Lines*. The *Optic Axial Angle* is the term currently employed to designate the acute angle between the two optic axes; the true angle within the crystal is symbolised as $2V_c$, and the apparent angle as measured in air as $2E$. (See page 167.)

Parallelohedron.—A solid formed by pairs of parallel faces. For instance, the cube is a triparallelohedron and the rhombic dodecahedron is a hexapallelohedron. (See Fig. 166.)

Parametral Plane.—The important facial plane cutting all three crystal axes which is chosen to determine the unit lengths of those axes, and thus thereby determines the important crystal element known as the Ratio of the Axes, $a : b : c$. In this ratio the length of the axis b is made equal to 1, and the lengths of a and c are proportionally expressed thereto. The indices of the parametral plane are consequently (111).

Periodic Law or Periodic Classification of the Elements.—First suggested by Newlands in the year 1864, and called by him the Law of Octaves, and subsequently worked out in detail by Mendeléeff in 1869 and later years. The formal statement of the law is that: "The properties of the elements, as well as those of their compounds, are periodic functions of the atomic weights of the elements."

When the elements are arranged in order of atomic weight it is found that, after the first two, hydrogen and helium, they progress regularly in properties, both chemical such as valency or type of compounds formed, and physical such as atomic volume, for an octave or period of eight elements; after this they recommence with similar properties as at first, and repeat the same kind of progression for a further octave or period (there being sometimes ten elements instead of eight in the period), this periodic repetition eventually affording us the Periodic Table of the Elements which is given in Appendix III at the end of the

book. The elements in each horizontal row form the period, octave, or series, which begins with a strongly electropositive element, and passes through feeble and neutral ones to a strongly electronegative element and ending with an inert gas or a noble metal, and there are twelve such series, which are numbered in order in the extreme left-hand column. The vertical columns comprise family groups of elements of similar valency and type of compounds formed, and these eight groups are numbered I to VIII at the top of the table.

The first group contains the monad alkali metals, group II the dyad alkaline earth metals, the third group the triad boron-aluminium family, group IV the tetrad carbon-silicon family, the fifth group the nitrogen-phosphorus family of pentads or triads, the sixth group the sulphur-selenium hexad or dyad elements, group VII the halogens, usually monads but occasionally possibly heptads, and the eighth group contains the inert gases of the neon-argon family, as well as three even-series-sets of three similar elements each, iron-nickel-cobalt, ruthenium-rhodium-palladium, and osmium-iridium-platinum. Indeed there are in general two sub-families in each vertical group, those of the odd series and those of the even series, the members of these sub-groups being families having the closest possible relationship, such for instance as potassium, rubidium, and caesium, the series -4 , -6 , and -8 members of group I, or argon, krypton, xenon, and niton, the series -3 , -5 , -7 , and -11 , members of group VIII.

There are three cases where the order of two adjacent elements is reversed as regards atomic weight, argon and potassium, nickel and cobalt, and iodine and tellurium. In these cases the order given is that of their undoubted chemical and physical properties. The sequence number of any element in the table as given is its Atomic Number as determined by Moseley, and the five gaps with atomic numbers 43, 61, 75, 85 and 87 are awaiting the discovery of new elements which he indicated as likely to be discovered. Including these, the total number of elements is 92, this being the atomic number of uranium, the radio-active element which is so near instability that it is unlikely any further elements beyond it can exist. The structure of the atoms of these elements, and the corresponding progression in complexity which their structure displays—the periods corresponding to the successive shells of electrons—is discussed in Chapter X.

Pinakoid.—A form composed of two parallel faces, from $\pi\acute{\iota}\nu\alpha\kappa\acute{\iota}$ a slab. The *Brachypinakoid* is the pair of vertical faces of a rhombic crystal parallel to the vertical axis c and to the front-to-back axis a , and to which the lateral axis b is normal; their indices are (010) and $(0\bar{1}0)$, and the form symbol (these two faces being a separate form) is $\{010\}$. The same term applies in the triclinic system, but the axis b does not cut the brachypinakoid faces at right angles. The *Macropinakoid* consists of the other complementary pair of faces, parallel to the vertical c axis and the lateral axis b , of a rhombic or triclinic crystal, and to which the a axis is normal in a rhombic crystal but cuts the faces at an angle other than 90° in a triclinic crystal. The indices are (100) and $(\bar{1}00)$, and the form symbol $\{100\}$. The *Basal*

Pinakoid consists of the pair of faces perpendicular to the vertical axis c of a tetragonal, hexagonal or rhombic crystal, and which is otherwise inclined to the c -axis of a monoclinic or triclinic crystal while parallel to the other two axes a and b . The symbols are (001) and $(00\bar{1})$ except in the hexagonal system, where they are (0001) and $(000\bar{1})$; the form symbol is $\{001\}$ or $\{0001\}$. In the trigonal system the basal pinakoid faces are equally inclined to the 3 rhombohedral crystal axes and perpendicular to the trigonal symmetry axis, the symbols being (111) and $(\bar{1}\bar{1}\bar{1})$ and the form symbol $\{111\}$. *Clinopinakoid* is the term given to the pair of faces of a monoclinic crystal parallel to the inclined axes a and c , and perpendicular to the symmetry axis b . The symbols are (010) and $(0\bar{1}0)$ and the form symbol $\{010\}$. *Orthopinakoid* is the name attached to the pair of primary faces of a monoclinic crystal parallel to the vertical axis c and to the symmetry axis b , but inclined at other than 90° to the front-and-back a -axis; the symbols are (100) and $(\bar{1}00)$, and the form symbol $\{100\}$.

Polariscope.—An instrument formed essentially by two Nicol prisms (see this term), or other effective producers of plane-polarised light (a pair of colourless tourmaline plates, for instance), arranged in succession in the beam of light from a suitable source; the latter may conveniently be sunlight reflected by a mirror as in the microscope-polariscope, a lamp (electric or with gas-mantle), or for projection purposes an electric-arc lantern with its condenser. The "Nicol" on which the light is first incident is called the "Polariser," and the second the "Analyser." A lens or train of lenses is added for projection purposes, or for rendering the beam parallel or convergent. For projection purposes the polariser carries a convexo-concave lens to parallelise the beam from the lantern condenser, and a water cell is placed between it and the condenser to protect the calcite prism and its balsam joint from heat rays. See Figs. 114 and 122. When the two Nicols are so arranged that their vibration planes (parallel to their shorter diagonals) are similarly placed, say, both vertical or both horizontal, they are said to be "Parallel," and when at right angles to each other "Crossed." When parallel the plane-polarised beam of light is transmitted by both just as by one alone; but when crossed the plane-polarised light transmitted by the polariser is stopped by the analyser, no light escaping, the "Dark Field" being produced; vibrations at right angles to its own vibration direction are not allowed to pass at all, more or less resolution, such as occurs when the prisms are not exactly at 90° , being impossible. In general, when a crystal other than a cubic one is placed between the two crossed Nicols, and rotated in its own plane, light again appears, four times during a complete revolution, brightest at 45° from the four extinction positions, the crystal then being clearly visible and generally coloured. These phenomena are the combined effects of the double refraction of the crystal and the interference of the two rays, which are produced by resolution in the crystal even out of the plane-polarised beam from the polariser, at the 45° positions from the extinction positions; the interference is rendered possible by the fact that the analyser subsequently again resolves

the two rays separately, and transmits only in each case the portion so resolved composed of vibrations in its own plane from each of the two rays, and these being in two different phases owing to their difference in velocity are in the condition to interfere, with chromatic effect if the thickness be favourable.

Primitive Circle.—The outer limiting circle of the stereographic projection, on which lie the poles (dots on the projection) of all faces belonging to that zone the faces of which are perpendicular to the plane of projection (the paper).

Prism.—In the crystallographic sense a prism is usually a "form" of four or more faces belonging to the same zone, but possibly of only three faces in the trigonal system; the edges are all parallel to the zone axis, and often to a crystallographic axis. In the ordinary optical sense, as used for spectroscopic or refractive index work, a prism is a short three-sided column of glass or crystal, of triangular section which is conveniently for most purposes equilateral, and with truly plane faces, the refracting angle employed being thus 60° . If required for the purpose of diverting a beam of light at right angles to its former direction, the three-sided glass prism is given a right angle, two faces being inclined at 90° to one another and the third face at 45° to each of them. Light incident normally on one of the two mutually rectangular faces is totally reflected (45° being greater than the critical angle of glass) at the hypotenuse face, and makes its exit from the other of the two faces at right angles to its original direction, normally to this second face.

Racemism.—The combination of the right- and left-handed varieties of an enantiomorphous substance to form a molecular compound, which is known as a racemic compound. The classic first known instance is the combination of monoclinic right- and left-handed tartaric acid to form triclinic racemic acid (which has given its name to the phenomenon), both anhydrous racemic acid and the acid which crystallises from water with one molecule of water of crystallisation being deposited from solvents in triclinic crystals, of course of two different types with different crystal elements. (See pages 156 and 160.) *Pseudo-racemism* is said to occur when very intimate fine lamellar alternating twinning of the two enantiomorphs (optical antipodes showing "hemihedral" or hemimorphic forms) results in the production of an apparently homogeneous substance of holohedral character. (See page 162.)

Law of Rational Indices.—The law limiting the number of possible facial "forms" developed on a crystal to those the intercepts of which on the axes are integral whole-number multiples of the intercepts made by the parametral plane which determines the relative lengths of the crystal axes. As intercepts are inversely proportional to the Millerian indices, the law of rationality applies equally to indices and to intercepts. (See Chapter V.)

Rays, Ordinary and Extraordinary.—These names are given to the

two rays into which a beam of light entering an optically uniaxial crystal (one belonging to the tetragonal, hexagonal, or trigonal systems) is divided. The Ordinary Ray is that one the vibrations of which always occur perpendicularly to the optic axis as well as to the ray, and therefore parallel to and along a diameter of the circular section of the ellipsoid of revolution, and which afford the refractive index ω . The Extraordinary Ray is the other one, and its vibrations occur not only perpendicularly to the direction of transmission of the ray but also in a principal section of the ellipsoid (one containing the axis), so that when the direction of the ray is actually in the circular section of the ellipsoid the vibrations are parallel to the optic axis, and afford the refractive index ϵ . (See also term Uniaxial.)

Reflection.—The law of reflection of light at a plane surface is that the reflected rays make the same angle with the normal to the plane (or with the plane itself) as that made by the incident rays with the normal (or the plane). Both incident and reflected rays lie in the same plane, perpendicular to the surface.

Refraction.—The term applied to the bending of light on passing from one medium into another of a different density. A clue to the amount of bending is afforded by the relations of the indices of refraction of the two media, and if one medium be the air, by the refractive index of the other medium directly. The incident and the refracted rays also lie in the same plane, which is perpendicular to the surface of separation of the two media. (See term Index of Refraction.)

Regular Point-Systems.—The 65 arrangements of points made known to us by Sohncke, corresponding to 65 of the 230 homogeneous structures possible to crystals. They include no types having space-operations or coincidence-movements of the second order. (See term Symmetry Elements and Operations.)

Optical Rotation or Optical Activity.—The power of rotating the plane of polarisation of plane-polarised light, that is of altering the direction or azimuth of vibration of the light, the vibrations still remaining perpendicular to the direction of the ray.

Saturated and Supersaturated Solutions.—A solution is saturated when it contains as much of the substance (solute) dissolved in the solvent as is possible with stable equilibrium under the temperature conditions prevailing. A solution is supersaturated when it contains more than this amount of the substance dissolved. Owing to supersaturation being so common when the solution remains quietly at rest, saturation (without any supersaturation) can only be attained with certainty when the solution is standing over crystals of the solute. There are two stages of supersaturation, the "Metastable" and "Labile" conditions. A metastable supersaturated solution contains only a relatively small excess of the substance dissolved, such as makes it possible for crystallisation to be started by crystal germs falling into the solution from the air. (See term Germ Crystals.) The crystal germs must be composed either of the same substance as the solute, or of one closely isostructural with it, having nearly the same

molecular volume and dimensions of space-lattice cell (topic axial ratios). A labile supersaturated solution is one so strongly supersaturated as to be spontaneously crystallisable, that is, without any necessity for the introduction of suitable crystal germs or actual crystals of the substance or an isomorph. Even labile solutions may remain uncrystallised for a considerable length of time if maintained perfectly still; the slightest disturbance, however, will probably provoke the immediate deposition of crystals. (See Chapter VI and Fig. 47.)

Solid Angle.—A corner or quoin on a crystal formed by the meeting of three or more crystal faces.

Space-Lattice.—The homogeneous arrangement of rows of points in a three-dimensioned lattice. (See Figs. 64 and 75.) The elementary or unit parallelepipeda of which the structure is composed are usually referred to as the unit cells of the lattice, the rows of points being supposed to be connected by imaginary straight lines which thus form the edges of the cells. It is the dimensions of these cell-edges which are supposed to be relatively expressed by the topic axial ratios, the cell-content being represented by the molecular volume; the cell is supposed to be the habitat of the chemical molecule, or of a small group of molecules, and is thus the grosser unit of the crystal structure. Comparisons of these volume and dimensional constants can only legitimately be made, however, when the substances compared belong to an isomorphous series, for which the plan of the structure is the same throughout the series. (See Chapter X.) The absolute dimensions have in many cases now been determined by X-ray analysis. (See Chapter XII.)

Stereographic Projection.—A convenient kind of plan of the arrangement of the faces on a crystal. It is the projection on a flat surface (the paper) of the points (represented on the projection by round dots) at which normals to the crystal faces would cut the surface of a sphere, the centre of which is identical with the centre of the crystal. The normals are all supposed to radiate from the common centre, and the faces to be of sufficiently indefinite extent to enable such normals to be drawn to them. Casual relative facial development is thus eliminated. (See Fig. 51.) The diametral plane is the plane of projection, the eye being supposed to be placed at one of the poles of the sphere. Its advantage is that all zones of faces are represented on the projection either by a circle (the outer or "primitive" limiting circle), diameters, or circular arcs terminating at the ends of diameters. It thus lends itself remarkably well to the purposes of the calculation of crystal angles by spherical trigonometry, forming the diagram on which the calculations are based. (See pages 54 and 59.)

Stereometric Orientation of Atoms.—By this is meant the relatively fixed positions of the elementary atoms within the chemical molecule of a solid substance, and consequently within the solid substance itself when crystallised. Crystallographic research, especially by X-rays,

has definitely proved and located these fixed positions of the atoms in the crystal.

Structural Unit.—The elementary atoms in the chemical molecules of the substance are the ultimate structural units of the crystal, corresponding to the point-system (one of the 230 possible ones) to which the crystal conforms; and the molecule itself, or a small group of molecules (such as two, three, or four), forms the grosser unit of the crystal structure, corresponding to the unit cell of the space-lattice. (See term Space-Lattice.)

Sublimation.—The property possessed by some of the more volatile substances of vaporising, on more or less raising their temperature, at the ordinary atmospheric pressure, without liquefaction, and of depositing themselves in the solid, usually crystalline, form on a cooler part of the containing vessel or on a cold object suspended above the vessel.

Symbol.—A concise expression for a crystal face, "form," or zone. It is enclosed within brackets, which are ordinary curved ones in the case of a face (), doubly curved ones { } for a "form," and square ones [] for a zone. The symbol of a face is composed of its Millerian indices, h , k , l , which are numbers inversely proportional to the intercepts made by the face on the crystal axes, expressed as multiples of the unit axial lengths, a , b , c . These multiples are usually small and always integral (no fractions), so that the Millerian indices are also such numbers as 0, 1, 2, 3, 4, and rarely a few higher numbers on crystals very rich in faces. A principal face of the form in the right top front octant is usually taken as representative of the "form," and its indices enclosed in the form brackets. For a zone the symbol is got by cross-multiplying the numbers in the symbols of two adjacent faces of the zone, and enclosing them in square brackets. If a face cuts a crystal axis on its negative half (to the left, behind, or below the centre), the index number carries a negative sign over that particular index number. Thus the front-right face of the icositetrahedron, the form symbol of which is {211}, is (211), and its left front face ($2\bar{1}1$). As an example of a zone symbol we may take the following: The face (211) lies on a zone containing also the faces of the cube and rhombic dodecahedron (100) and (011), and cross-multiplication of these two facial symbol-indices gives for the symbol of the zone [011]. The same icositetrahedron face also lies on another zone (at its intersection with the zone just referred to) containing the faces (110) and (101); cross-multiplication of these two latter symbols gives the form symbol [$1\bar{1}\bar{1}$]. If now we cross-multiply these two form symbols we get the indices of the face at their intersection, namely (211), and if we did not already know the indices of this icositetrahedron face we should have here a means of determining them.

Symmetry Elements and Operations of the First and Second Order.—The elements of symmetry are the Plane of Symmetry and the Axis of Symmetry. The Centre of Symmetry is also frequently called an

element of symmetry ; it is really produced, however, by the combination of rotation for 180° or 60° about an axis of symmetry followed by reflection across a plane of symmetry.

Symmetry Properties or Operations of the First Order consist of a simple rotation about an axis of symmetry, or a combination of a rotation with a translation, which is equivalent to rotation about a screw axis. The axis of symmetry is the special characteristic of first order symmetry, and it may be digonal, trigonal, tetragonal, or hexagonal, according to the number of times in a complete rotation the crystal or point-system in question is brought to apparent coincidence. Symmetry Operations, or Coincidence Movements, of the Second Order, include reflection across a plane of symmetry, inversion (equivalent to the presence of a centre of symmetry), or a rotatory reflection (the characteristic of second order symmetry) about an axis and a plane, also called a mirror-axis of symmetry.

System.—The 32 classes of crystal symmetry are grouped naturally into seven great Systems, in each of which the mode of choice of the crystal axes for the classes composing it is the same, and in which also all the classes of the group possess certain minimum indispensable and characteristic (systematic) elements of symmetry in common. They may be regarded as the Seven Styles of Crystal Architecture, considering main lines only and not going into too much detail. They are the cubic, tetragonal, hexagonal, trigonal, rhombic, monoclinic, and triclinic systems. The distribution of the 32 classes of crystals among them is set out in Appendix II.

Tetartohedral.—An obsolete term used when only one-fourth of the full number of faces of a form, or forms, are developed, which are possible to a crystal belonging to the highest (holohedral) class of the system in question. It is now recognised as due to the operation of fewer elements of symmetry and not to any suppression of possible faces.

Topic Axial Ratios.—The same as Molecular Distance Ratios. (See the latter.)

Transition Tint.—The violet tint of passage afforded by a biquartz, between crossed or parallel Nicols according as the biquartz plate is 7.5 or 3.75 millimetres thick. With the slightest movement of the analyser from the position of crossing or parallelism, one-half of the biquartz changes colour vividly to red and the other half to blue or green, the tints being, more or less, complementary in the two halves.

Truncation.—By this term is meant the modification (replacement) of an edge between similar faces, or of a solid angle formed by similar faces of a crystal, by a face making equal angles with the adjacent faces. By *Beveling* is meant the replacement of an edge formed by similar faces by a pair of faces equally inclined to them. The term *Replacement*, used in a technical sense, is intended to imply that an edge or corner is replaced by a face unequally inclined to the adjacent faces.

Uniaxial.—An optical term referring to the more symmetrical of the two great types of doubly refractive crystals, namely, those belonging to the trigonal, tetragonal, and hexagonal classes. The presence of a single symmetry axis of trigonal, tetragonal, or hexagonal character determines that the ellipsoid representing the optical properties shall be one of revolution about this axis, which is thus a unique direction of single refraction in the crystal. A ray of light passing along this axis may vibrate equally in all azimuths (diameters) in the circular section of the ellipsoid, to which the axis is normal, and thus experiences no tendency to divide into two rays. Vibrations of this kind in the circular section correspond to the refractive index ω . A ray travelling in the circular section, however, does break into two rays (as does any ray not travelling exactly along the axis) and they are rectangularly plane-polarised with respect to each other, one (known as the ordinary ray) vibrating perpendicularly to the ray in the same circular section and affording ω , and the other (known as the extraordinary ray) vibrating perpendicularly to the ray and parallel to the axis, and affording the other refractive index ϵ . In convergent polarised light between crossed Nicols, a plate of a uniaxial crystal cut perpendicularly to the axis affords the well-known interference figure of a black cross and circular spectrum-rings concentric with the centre of the cross. (See pages 182 and 186, and Fig. 115.)

Vicinal Faces.—Faces with very high indices, which are often found to replace primary faces, the angles between them and the primary faces being very small, often less than a degree. A full explanation of them will be found on pages 49 to 51.

Zone.—A term given to a number of crystal faces all of which, and their edges of intersection, are parallel to the same direction, that of the zone axis. It is characteristic of crystal faces to lie in zones. The arrangement of the faces in the zone is a more or less symmetrical one, according to the class of symmetry to which the crystal conforms, and in most cases each face in the zone has a complementary parallel one on the other side of the crystal. The poles of all the faces of the zone lie on the same zone-circle on the stereographic projection, which is either a circular arc or a diameter, or, in the case of the important zone of faces perpendicular to the plane of projection, the primitive circle itself. (See also under the term Symbol.)

APPENDIX II

LIST OF THE 32 CLASSES OF CRYSTALS AND THEIR DISTRIBUTION AMONG THE SEVEN SYSTEMS, GIVING THEIR SYMMETRY ELEMENTS AND TYPICAL EXAMPLES

CUBIC SYSTEM

Three equal rectangular crystal axes, a , b , c , all three written, therefore, as a .

Class 32.—Hexakis-octahedral or holohedral class. Three equal rectangular tetragonal symmetry axes, four equal trigonal axes equally inclined to them, six digonal axes bisecting the angles between the tetragonal axes, three symmetry planes perpendicular to the tetragonal axes, and six other symmetry planes bisecting their angles.

Example: Fluorspar, CaF_2 .

Class 31.—Hexakis-tetrahedral class. Three equal rectangular digonal axes, four equal trigonal axes equally inclined to them, and the six symmetry planes.

Example: Tetrahedrite, Cu_3SbS_3 .

Class 30.—Dyakis-dodecahedral class. Three equal rectangular digonal axes, four equal trigonal axes equally inclined to them, and three planes of symmetry perpendicular to the digonal axes.

Example: Pyrites, FeS_2 .

Class 29.—Pentagonal-icositetrahedral class. Three equal rectangular tetragonal axes, four trigonal axes as before, and the six digonal axes, no symmetry planes.

Example: Cuprite Cu_2O .

Class 28.—Tetrahedral-pentagonal-dodecahedral class. Three equal rectangular digonal axes and four equal trigonal axes equally inclined to them.

Example: Barium nitrate, $\text{Ba}(\text{NO}_3)_2$.

HEXAGONAL SYSTEM

Three equal lateral crystal axes, a , a , a , mutually inclined at 60° , and a vertical crystal axis, c , of different length, perpendicular to them.

Class 27.—Dihexagonal-bipyramidal or holohedral class. One hexagonal axis and six symmetry planes intersecting in it; also a symmetry plane and six digonal axes perpendicular to the hexagonal axis.

Example: Beryl, $\text{Be}_3\text{Al}_2(\text{SiO}_3)_6$.

Class 26.—Dihexagonal-pyramidal class. One hexagonal axis and six symmetry planes intersecting in it.

Example: Greenockite, CdS .

Class 25.—Bipyramidal class. One hexagonal axis and one plane of symmetry perpendicular to it.

Example: Apatite, $\text{Ca}_5\text{F}(\text{PO}_4)_3$.

Class 24.—Trapezohedral class. One hexagonal axis and six digonal axes in the plane perpendicular to it.

Example: The complex salt of tartaric and nitric acids $(\text{C}_4\text{H}_4\text{O}_6)_2(\text{SbO})_2\text{Ba}\cdot\text{KNO}_3$.

Class 23.—Pyramidal class. One hexagonal axis of symmetry.

Example: Strontium antimonyl tartrate, $\text{Sr}(\text{SbO})_2(\text{C}_4\text{H}_4\text{O}_6)_2$.

TRIGONAL SYSTEM

Three equal and equally inclined crystal axes, a , b , c , all three, therefore, written as a .

Class 22.—Ditrigonal-bipyramidal or holohedral class. A trigonal axis and three symmetry planes intersecting in it; also a symmetry plane and three digonal axes all perpendicular to the trigonal axis.

Example: Silver hydrogen phosphate, Ag_2HPO_4 .

Class 21.—Ditrigonal-scalenohedral class. One trigonal axis and three symmetry planes intersecting in it; also three digonal axes in the plane perpendicular to the trigonal axis.

Example: Calcite, CaCO_3 .

Class 20.—Ditrigonal-pyramidal class. One trigonal axis and three symmetry planes intersecting in it.

Example: Tourmaline, $\text{H}_6\text{Na}_2\text{Fe}_4\text{B}_6\text{Al}_3\text{Si}_{12}\text{O}_{63}$.

Class 19.—Bipyramidal class. One trigonal axis and a plane of symmetry perpendicular to it.

No example yet found.

Class 18.—Trapezohedral class. One trigonal axis and three digonal axes in the plane perpendicular to it.

Example: Quartz, SiO_2 .

Class 17.—Rhombohedral class. One trigonal axis of symmetry which is also a hexagonal axis of compound symmetry.

Example: Dioptase, CuH_2SiO_4 .

Class 16.—Pyramidal class. One trigonal axis of symmetry.

Example: Sodium periodate, $\text{NaIO}_4\cdot 3\text{H}_2\text{O}$.

TETRAGONAL SYSTEM

Three rectangular crystal axes, the two horizontal ones, a and b , being equal (therefore both written as a), but the third vertical one, c , of different length.

Class 15.—Ditetragonal-bipyramidal or holohedral class. One tetragonal axis and four symmetry planes intersecting in it; also a

symmetry plane and four digonal axes all perpendicular to the tetragonal axis.

Example : Zircon, $ZrSiO_4$.

Class 14.—Scalohedral class. One tetragonal axis and a plane of compound symmetry perpendicular to it; two rectangular digonal axes lying in the latter plane, and two symmetry planes intersecting in the tetragonal axis and bisecting the angles of the two digonal axes.

Example : Potassium dihydrogen phosphate, KH_2PO_4 .

Class 13.—Ditetragonal-pyramidal class. One tetragonal axis and four symmetry planes intersecting in it.

Example : Iodosuccinimide, $C_4H_4O_2NI$.

Class 12.—Bipyramidal class. One tetragonal axis and a plane of symmetry perpendicular to it.

Example : Scheelite, $CaWO_4$.

Class 11.—Trapezohedral class. One tetragonal axis and four digonal axes in the plane perpendicular to it.

Example : Strychnine sulphate $(C_{21}H_{22}N_2O_2) \cdot H_2SO_4 \cdot 6H_2O$.

Class 10.—Bisphenoidal class. One tetragonal axis and a plane of compound symmetry perpendicular to it.

Example : The only one known is the compound, $2CaO \cdot Al_2O_3 \cdot SiO_2$.

Class 9.—Pyramidal class. One tetragonal axis of symmetry.

Example : Wulfenite, $PbMoO_4$.

RHOMBIC OR ORTHORHOMBIC SYSTEM

Three rectangular, but unequal crystal axes, a , b , c .

Class 8.—Bipyramidal or holohedral class. Three rectangular digonal axes and three planes of symmetry perpendicular to each other.

Example : Potassium sulphate, K_2SO_4 .

Class 7.—Pyramidal class. A digonal axis and two mutually perpendicular planes of symmetry parallel to it.

Example : Ammonium magnesium phosphate (struvite), $NH_4MgPO_4 \cdot 6H_2O$.

Class 6.—Bisphenoidal class. Three rectangular digonal axes of symmetry.

Example : Magnesium sulphate, $MgSO_4 \cdot 7H_2O$.

MONOCLINIC OR MONOSYMMETRIC SYSTEM

Three unequal axes, two of which, a and c , are mutually inclined, but the third, b , is perpendicular to these two.

Class 5.—Prismatic or holohedral class. A symmetry plane and a digonal axis perpendicular to it.

Example : Potassium magnesium sulphate, $K_2Mg(SO_4)_2 \cdot 6H_2O$.

Class 4.—Sphenoidal class. A digonal axis of symmetry.

Example: Tartaric acid, $C_4H_6O_6$, two oppositely enantiomorphous forms, right- and left-handed.

Class 3.—Domal class. A plane of symmetry.

Example: Potassium tetrathionate, $K_2S_4O_6$.

TRICLINIC OR ANORTHIC SYSTEM

Three inclined and unequal axes, a , b , c .

Class 2.—Pinakoidal or holohedral class. A digonal axis and a plane of compound symmetry perpendicular to it, equivalent to a centre of symmetry.

Example: Copper sulphate, $CuSO_4 \cdot 5H_2O$.

Class 1.—Asymmetric class. No symmetry.

Example: Calcium thiosulphate, $CaS_2O_3 \cdot 6H_2O$.

APPENDIX III.—THE PERIODIC CLASSIFICATION OF THE ELEMENTS.

		FAMILY GROUPS.						
I.		II.	III.	IV.	V.	VI.	VII.	VIII.
R ₂ O.		R ₂ O ₂ .	R ₂ O ₃ .	R ₂ O ₄ .	R ₂ O ₅ .	R ₂ O ₆ .	R ₂ O ₇ .	R ₂ O ₈ .
1	<i>1-008</i> 1 H=1-000							<i>4-0</i> 2 He=4
2	3 Li=6-98 <i>7-00</i>	4 Be=9-03 <i>9-1</i>	5 B=10-9 <i>11-0</i>	6 C=11-91 <i>12-00</i>	7 N=13-90 <i>14-01</i>	8 O=15-88 <i>16-00</i>	9 F=18-9 <i>19-0</i>	10 Ne=19-9 <i>20-6</i>
3	<i>23-00</i> 11 Na=22-88	<i>24-32</i> 12 Mg=24-18	<i>27-1</i> 13 Al=26-9	<i>28-3</i> 14 Si=28-2	<i>31-00</i> 15 P=30-77	<i>32-07</i> 16 S=31-82	<i>35-46</i> 17 Cl=35-18	<i>39-9</i> 18 Ar=39-6
4	19 K=38-85 <i>39-10</i>	20 Ca=39-7 <i>40-09</i>	21 Sc=43-8 <i>44-1</i>	22 Ti=47-7 <i>48-1</i>	23 V=50-8 <i>51-2</i>	24 Cr=51-7 <i>52-1</i>	25 Mn=54-6 <i>54-93</i>	<i>55-85</i> 26 Fe=55-5 <i>55-97</i> 27 Co=58-5 28 Ni=58-3 <i>58-68</i> (Cu=63-1) <i>63-57</i>
5	<i>63-57</i> 29 Cu=63-1	<i>65-37</i> 30 Zn=64-9	<i>69-9</i> 31 Ga=69-5	<i>72-5</i> 32 Ge=72	<i>75-0</i> 33 As=74-4	<i>79-2</i> 34 Se=78-6	<i>79-92</i> 35 Br=79-36	<i>82-9</i> 36 Kr=82-3 <i>102-9</i> 37 Rb=84-9 <i>85-45</i> 38 Sr=86-94 <i>87-62</i> 39 Yt=88-3 <i>89-0</i> 40 Zr=89-9 <i>90-6</i> 41 Cb=92-8 <i>93-5</i> 42 Mo=95-3 <i>96-0</i> 43— 44 Ru=100-9 <i>101-7</i> 45 Rh=102-2 46 Pd=105-7 <i>106-7</i> (Ag=107-11) <i>107-88</i>
6	37 Rb=84-9 <i>85-45</i>	38 Sr=86-94 <i>87-62</i>	39 Yt=88-3 <i>89-0</i>	40 Zr=89-9 <i>90-6</i>	41 Cb=92-8 <i>93-5</i>	42 Mo=95-3 <i>96-0</i>	43—	44 Ru=100-9 <i>101-7</i> 45 Rh=102-2 46 Pd=105-7 <i>106-7</i> (Ag=107-11) <i>107-88</i>
7	<i>107-88</i> 47 Ag=107-11	<i>112-40</i> 48 Cd=111-6	<i>114-3</i> 49 In=114-1	<i>119-0</i> 50 Sn=118-1	<i>120-2</i> 51 Sb=119-3	<i>127-5</i> 52 Te=126-6	<i>126-92</i> 53 I=126-01 61—	<i>130-2</i> 54 Xe=129-3
8	55 Cs=131-9 <i>132-81</i>	56 Ba=136-4 <i>137-37</i>	57 La=139-0	58 Ce=140-25	59 Pr=140-6	60 Nd=144-3	61—	62 Sa=150-4 <i>152-0</i> 63 Eu=152-0 64 Gd=157-3 65 Tb=159-2 66 Ho=163-5 67 Ds=162-5 68 Er=167-7 69 Tm=168-5 70 Yb=170-7 <i>172</i> 71 Lu=174-0 72—Probably Hafnium 73 Ta=179-6 <i>181-0</i> 74 W=182-6 <i>184-0</i> 75— 76 Os=189-6 77 Ir=191-5 78 Pt=193-3 <i>195-0</i> <i>190-9</i> <i>193-1</i> <i>197-2</i> (Au=196-7)
9	62 Sa=150-4	63 Eu=152-0	64 Gd=157-3	65 Tb=159-2	66 Ho=163-5	67 Ds=162-5	68 Er=167-7	69 Tm=168-5 70 Yb=170-7 <i>172</i> 71 Lu=174-0 72—Probably Hafnium 73 Ta=179-6 <i>181-0</i> 74 W=182-6 <i>184-0</i> 75— 76 Os=189-6 77 Ir=191-5 78 Pt=193-3 <i>195-0</i> <i>190-9</i> <i>193-1</i> <i>197-2</i> (Au=196-7)
10	69 Tm=168-5	70 Yb=170-7 <i>172</i>	71 Lu=174-0	72—Probably Hafnium	73 Ta=179-6 <i>181-0</i>	74 W=182-6 <i>184-0</i>	75—	76 Os=189-6 77 Ir=191-5 78 Pt=193-3 <i>195-0</i> <i>190-9</i> <i>193-1</i> <i>197-2</i> (Au=196-7)
11	<i>197-2</i> 79 Au=195-7	<i>200-0</i> 80 Hg=198-5	<i>204-0</i> 81 Tl=202-6	<i>207-10</i> 82 Pb=205-35	<i>208-0</i> 83 Bi=206-4	84—Polonium	85—	86 Nt=221 <i>222-4</i>
12	87—	88 Ra=225 <i>226-4</i>	89—Actinium	90 Th=230-8 <i>232-42</i>	91—Eka- tantalum	92 U=236-7 <i>238-5</i>		

The figures in heavy type are the atomic numbers, as given by Moseley.

The atomic weights in ordinary black figures are those authorised by the International Committee on Atomic Weights, 1905, for hydrogen = 1, corrected and brought up to date as regards trustworthy determinations which have since been made.

The figures in italic type are on the basis of O=16, as authorised by the International Committee.

The element ionium is isotopic with thorium, its atomic weight being 2 units less than that of thorium. Radium-D is isotopic with lead. Mesothorium-I is isotopic with actinium. Mesothorium-II is isotopic with actinium. Radium-A is isotopic with polonium.

INDEX

- Airy's spirals afforded by pair of oppositely rotatory quartz plates, 190, Fig. 121 (Plate XXI); afforded by quartz twins, 190, 191.
- Alkali sulphates, 98-100; expansion of, 237; structure of, 129; four molecules in crystal unit of, 148; and selenates, dimorphism of, 148.
- Allotropy, 253.
- Alpine snowfield, 32, Fig. 37 (Plate XI).
- Alum, ammonium iron, crystallising on hair, Fig. 26 (Plate VI); caesium, 28, Fig. 25 (Plate V); potash, crystallisation of, from solution, 3, 10, 11, 65, Fig. 4 (Plate II); vicinal faces on, 49-51.
- Aluminium trichloride, 241.
- Alums, mixed crystals of, 65.
- Amethyst quartz, gross illustration of pseudo-racemism, 211; laminated structure of, 208, 209, Fig. 139; plan of (Judd), 209, Fig. 139; section-plate with violet sectors, 207, Fig. 137 (Plate XXVI); section-plate in parallel polarised light, 206, 207, Fig. 136 (Plate XXV), Fig. 138 (Plate XXVI).
- Ammonia, nature of, 68; NH_4 group isomorphous with alkalis, 68, 69, 105.
- Ammonium chloride, crystallisation of, from labile solutions, 49; from solutions containing urea, 49.
- " iron alum crystallising on a hair, 28.
- " magnesium phosphate crystals, 29, Fig. 29 (Pl. VII).
- " magnesium sulphate, 29, Fig. 30 (Plate VIII), 66.
- " oleate "liquid crystals," 218, Fig. 145, 219, Figs. 146 and 147; composition of, 218, 223; diagrammatic representation of upright molecules of, 219, Fig. 148; twins and broken individuals of, 220, Figs. 149, 150 and 151.
- Ammonium phosphate and arsenate, 62, 63, 67.
- " selenate, monoclinic form of, 148; rhombic form in mixed crystals with rubidium selenate, 148.
- " sulphate, isostructural with rubidium sulphate, 105, 129, 245.
- Ampère's researches on sal-ammoniac, 68, 69.
- Anatase, crystal of, 24, Fig. 18.
- Angle between crystal faces measured on goniometer, 55.
- Angles, axial, 39.
- " crystal, 253; constancy of, 4, 5, 11, 12, 53, 99, 107.
- Anhydrite, X-radiograms of, 127 and Plate XVIII.
- Anisotropic, 253.
- Anthracene, structure of, 132, 133; unit cell of, 132.
- Antimony oxide, dimorphous forms of, 71, Fig. 55 (Plate XIII).
- Antipodes, optical, 253.
- Apatite, crystal of, 24, Fig. 17.
- Aragonite, optic axial interference figures of, 186, Figs. 116 and 117 (Plate XX).
- Arsenious oxide, crystallisation of, from vapour, 3; dimorphous forms of, 71.
- Artificial biquartz to show black band, 203, Fig. 131 (Plate XXIII).
- Astatic magnet-systems, Plate XXX facing 224, and Fig. 158 (Plate XXXI).
- Astbury, W. T., structure of tartaric acid, 135-137; of racemic acid, 137-139.
- Aston, F. W., discovery of isotopes, 91.
- Asymmetric atoms, 253; of elements other than carbon, 163; carbon atoms and optical activity, 156.
- Atom, nature of the chemical, 87; Rutherford's researches on, 87; structure of, 88; Moseley's law defining, 87.
- Atomic diameters, 93; law of (W. L. Bragg), 141, 246, 247.
- " nucleus, mass of, 90.

- Atomic number, Moseley's law concerning, 87.
 „ structure theories, 87-89.
- Atoms, distribution of, in molecule, 93; empty spaces within, 93; spheres of influence of, 93.
- Axes and axial planes of crystals, 34, 35, 38, 254.
- Axial ratios, 38, 60; angles, 39, 60.
- Azimuth angle in two-circle goniometry, 58.
- BABINET double quartz wedge-plate, 204, Fig. 132 (Plate XXIV).
- Barium nitrate, non-activity of, 161.
- Barker, T. V., research on perchlorates, 99.
- Barlow, W., the 230 point-systems, 96, 97; and Sir W. J. Pope, valency volume theory, 129, 141, 241-246.
- Bartolinus, Erasmus, discovery of cleavage of calcite, 11.
- Beckenkamp, J., preservation of molecule in crystal, 145.
- Bequerel, H., discovery of radioactivity, 250
- Benzoic acid, growing crystals of, in polarised light, 210, 211, Fig. 140 of frontispiece.
- Bergmann and Gahn, constancy of cleavage directions, 12.
- Beryl, X-radiogram of, 127, Plate XVII.
- Berzelius and Mitscherlich, atomic weights and isomorphism, 67, 68, 69, 70.
- Betol, crystallisation of, 46.
- Beudant, researches on vitriols, 64
- Bevelling, 269.
- Biaxial crystals, 254; 60°-prisms and refractive indices of, 169, 170, 183; optic axes of, 183; optic axial angle of, 187, 188, Fig. 118.
- Biot, J. B., different optical behaviour of tartaric and racemic acids, 155, 156; convention for right- and left-handedness, 180.
- Biquartz, 181, 255; a natural, 201, 202, Fig. 129; construction of, 181; use of, 199.
- Bisectrix, acute or obtuse, of optic axial angle, 195.
- Black band, shown by natural biquartz with oblique junction, 202, Fig. 130 (Plate XXIII).
- Bohr, N., version of atomic structure theory, 88, 100, 146.
- Boisbaudran, Lecoq de, researches on supersaturation, 43.
- Boyle, Robert, nature of crystals, 11.
- Bragg, Sir Wm. H., 251; explanation of reflection of X-rays by crystals, 111, 112; explanatory diagram, 113; intensity of X-ray orders, 116; ionisation, explanation of, 115; location of connecting electrons in diamond and fluorspar, 145; spacing equation, 113; structure of anthracene, 132-134; of calcite, 124, 125; diamond, 122; fluorspar, 145, 146; ice, 124; iron pyrites, 144; naphthalene, 132-134, quartz, 125, 126; rock-salt, 115, 116; sylvine, 117; zinc blende, 121; the X-ray spectrometer, 112-115, 131.
- „ W. L., 251; law of atomic diameters, 140-142; location of electrons on shells, 146.
- Brauns, R., observations on variation of angles of lead nitrate, 52.
- Bravais, A., the 14 space-lattices, 94.
- Brazilian twins of quartz, 201, Figs. 127 and 128.
- Bricks or blocks, units of crystal edifice, 18, 19, 86, 95.
- Brookite, crossed-axial-plane dispersion of, 73, 76.
- Brushes, optic axial, of interference figures, 187.
- CÆSALPINUS, views concerning crystals, 10.
- Cæsium alum crystals, 28, Fig. 25 (Pl. V).
- „ atom, size of, 141.
- „ sulphate, a crystal of, 128, Fig. 91.
- Calcite, a crystal of, 25; behaviour of, in polarised light, 177, 178; in thin sections, 178; forms of, 7-9, Plate III; refractive indices of, 176; structure of, 124, 125, 144; 60°-prism of, experiments with, 171-173; modes of cutting, 171.
- Calcium chloride, 241.
- „ carbonate, dimorphism of, 66, 71.
- „ dextro-glycerate, crystal elements of, 165; crystal of, 166, Fig. 107; investigation of crystals of, 164-168; optical properties of, 168; stereographic projection of, 166; table of angles of, 167.
- „ sulphate, crystal of, 9; different forms of, 9, Plate IV.
- Calculations of crystal elements and angles, 60, 241; rules used in, 241.

- Carangeot's contact goniometer, 12, 13, Fig. 11.
- Carbon, allotropy of, 151.
- Carbon dioxide, liquid, in quartz cavities, 30, Fig. 34 (Plate X).
 ,, tetrachloride, 241.
- Cavendish, composition of water, 16.
- Chemical combination, theory of, from atomic structure, 89; cases of K and Cl, Ca and O, C and O, 89, 90.
- Cholesteryl acetate, projection of "liquid crystals" and spherulites of, 230-232, Fig. 161 (Plate XXXI) facing 226; benzoate, 217.
- Chromates, isomorphous with sulphates (Mitscherlich), 69.
- Classes, the 32, of crystals, 27; Appendix II, 271-274.
- Cleavage, 255; kernel, 17; of calcite, 17, 20; planes of, those most densely strewn with points, 150.
- Close packing of spheres, two modes of, 244.
- Cobalt sulphate, 66.
- Coincidence movements, 97, 255
- Colours of crystals in polarised light, 177-179; order of, in right and left quartz plates, 180.
- Configuration-determining force (Lehmann), 222, 223, 225.
- Constancy of crystal angles, 4, 5, 11, 12, 53, 99, 107.
- Contact goniometer of Carangeot, 12, 13; Duke of Buckingham's duplicate of, 12, 13, Fig. 11.
- Convergent polarised light, experiments with crystals in, 182 *et seq.*
- Copper sulphate, 64, 65; crystal of, 27, Fig. 23.
- Crookes, Sir William, experiments in high *vacua*, 250; liquefaction of carbon and crystallisation as diamond, 152.
- Crookes' tube, 91, 108, 151.
- Crops of crystals, different habits of, 60.
- Crossed-axial-plane dispersion of optic axes, 255; of gypsum, 72-76; of ethyl triphenyl pyrrolone, 83, Fig. 63 (Plate XV).
- Crystal axes, 38; choice of, 35; for descriptive purposes, 34; for fixation of positions of faces, 34, 35.
 ,, classes, 27, 255; list of the 32, Appendix II.
 ,, definition of, 3.
 ,, germs, 42, 45, 258.
 ,, growth, 2, 42, 50.
 ,, structure, 86 *et seq.*; two types of, fixed and not fixed by symmetry, 144.
- Crystal unit, molecular or poly-molecular, 93, 148.
- Crystallisation, nature of, 224; two general cases of, 46, 47; slow and rapid, 46, 47; under the microscope, 3, 27.
- Crystallographic description, 60, 65.
- Crystals, collection of, from good crops, 47; concise definition of salient properties of, 53; essential properties of, 4; mode of formation of, 3; production of measurable, 52.
- Cube, the, 25, 35; perfect symmetry of, 25.
- Cubic space-lattice, 116, 117; system, 25, 271.
- Curies, the, discovery of radium, 250.
- Curves of solubility and supersolubility, 44, 46, 47, Fig. 47.
- Cutting-and-grinding goniometer, 181.
- DALTON, John, atomic theory, 16, 250.
- Dark field of crossed Nicols, 184, 193.
- Darwin, C. G., and Compton, A. H., intensity of X-ray reflection, 146.
- Davy, Sir Humphry, researches on ammonia, 68.
- Debye P., and P. Scherrer, X-ray method of, and apparatus, 130.
- Delafosse, views on morphotropy, 80.
- Density of crystals, value of determination of, 104, 243.
- Description of a crystal, mode of making a, 34, 60.
- Deville and Troost, vapour density of tantalum chloride, 69.
- Diagram (curves) illustrating conditions for crystallisation, 44, Fig. 47.
- Diameters, law of atomic (W. L. Bragg), 140-142, curve expressing it, 141.
- Diamond, crystalline form of, 26, 197; its conversion into graphite, 151; its correspondence with carbon in fatty organic compounds, 145, 152; structure of, 122.
- Diamonds, experiment with crown of, 5; slide of ten, showing strain colours in polarised light, 197, Plate XXII facing 196.
- Dibenzal benzidine "liquid crystals," 220, Fig. 153 (Plate XXIX), 221.
- Dichroism and polychroism, 255.
- Diffraction, 255.
- Digonal axis, 24.
- Dilatometer, the interferential, 104, 235, 236, Fig. 163.
- Dimorphism, 256; of antimony oxide, 71, Fig. 55 (Plate XIII); of calcium carbonate, 66, 71; of mercuric iodide, 77; of sodium dihydrogen phosphate, 67; of sulphur, 70, 71; of vitriols, 66.

- Directive molecular orientative force in crystallisation, 51, 224.
 Dispersion, 256.
 Disruption of atoms by α -particles, 91.
 Dog-tooth spar, 7, 8, Fig. 7 (Plate III).
 Dorn and Stumpf, determination of two refractive indices of "liquid crystals," 221.
 Double refraction, 173, 256; amount of, for quartz and calcite, 176; interference colours due to, 177; of biaxial crystals, 183; of uniaxial crystals, 182; separation of two spectra, a measure of, 173, cases of quartz and calcite, 173.
 " sulphates and selenates with $6H_2O$, 23, 66, 76, 98 *et seq.*; unit of space-lattice probably contains one or possibly two chemical molecules, 148.
 EIGHT-millionth of an inch, scale unit of interferometer, 234.
 Elasmometer for determining modulus of elasticity of crystals, 237, 238, Fig. 164.
 Elasticity of crystals, 233; relations of, to symmetry, 233.
 Electrons, 87-89, 256; connecting, located by Sir Wm. Bragg, 145; mass of, 90.
 Elements of a crystal, 60.
 Eleven crystal classes with no symmetry plane, 160.
 Ellipsoid, optical, 183, 256.
 Enantiomorphism, 154, 257; and optical activity, 154, 155; definition of, 154; eleven classes showing, 160.
 Epsom salts, 64, 66.
 Equivalence parameters of Pope and Barlow, 243.
 Etched figures, 161, 257.
 Ethyl triphenyl pyrrolone, crystal of, 82, Fig. 62; crossed-axial-plane dispersion of, 83, 84 (Plate XV).
 Eutropic members of isomorphous series, 106.
 Expansion of water on freezing, 31; thermal, of crystals, 233; determination of, by interference dilatometer, 235, 236, Fig. 163; relations to symmetry, 233.
 External molecular compensation, 148, 157, 213.
 Extinction positions of crystal plates in polarised light, 177, 257.
 FACE-centred cube lattice, 116.
 Faces of crystals, occurrence in zones, 55; primary and secondary, 257.
 Fedorov, E. S., crystallochemical analysis, 247-249; determination of correct setting of crystals, 248; his "complex symbol," 248; parallelehedra of, 248, Fig. 166; "The Crystal Kingdom," table of crystal characters, 247-249; theory of crystal structure, 247; the 230 point-systems, 96, 97.
 Ferricyanide of potassium, crystals of, 29, Fig. 32 (Plate IX).
 Ferrocyanide of potassium, crystals of, 28, Fig. 27 (Plate VI).
 Ferrous sulphate, 64, 66.
 Fizeau, H., invention of interferometry, 235; thermal expansion of crystals, determination of, 235.
 Fletcher, Sir L., indicatrix of, 183, 256. "Flowing crystals," 223, 224.
 Fluorspar, single refraction of, 196; structure of, 123, 145.
 Form, a, 53, 258; definition of a, 7; fundamental, 13; limitation of number, 54; number of faces in a, 53; of $Ha\ddot{u}y$, 18; primitive ($Ha\ddot{u}y$), 18, (Romé de l'Isle), 13.
 Frankenheim, 79, 94.
 Friedel's rule, X-radiogram shows a centre of symmetry, 123.
 Fuchs, von, 64, 65.
 Fuess, R., reflecting goniometer, 55, 56, Fig. 52.
 GEM-STONES, essential properties of, 5. Geometrical theory of crystal structure, 97.
 Germ crystals, 27, 42, 45, 258.
 Gernez, researches on supersaturation, 43.
 Gessner, ideas of crystals, 10.
 Glancing angle of X-ray reflection, 118.
 Glide planes, 150; of calcite and ice, 215.
 Glyceric acid, 164.
 Gmelin, research on racemic acid, 155.
 Goniometer, contact, 12, 13, Fig. 11; reflecting, of Fuess, 55-57, of Troughton and Simms, 57; two-circle, of V. Goldschmidt, 57, 58; wax for, 56.
 Graphic granite, photomicrograph of, 177, Fig. 113 (Plate XIX) facing 150.
 Graphite, structure of, 131; correspondence with aromatic carbon, 134, 145, 152.
 Grayson rulings, as fiducial marks, 239.
 Great circles, zone circles, on Penfield's jelly sphere, 54.
 Groth, P. von, morphotropic aromatic compounds, 78, 80.
 Growth of crystals, 1, 42-47.

- Guglielmini, constancy of crystal angles, 11; discovery of principles of crystal structure, 11.
- Gypsum, crystal forms of, 9; cleavage of 194; experiments with even films of, 194, 195; with 60°-prism of, 170, 172, 173; section of, showing extinction directions, 195, Fig. 123; twin of, in polarised light, 196, Fig. 124.
- HABIT of crystals, 8, 60, 258; divergence of, in same substance, 8, 9; of calcite crystals, 8.
- Hardness of crystals, 215.
- Harkins, W. D., relative stability of elements, 92.
- Hatchett, discovery of columbium, 70
- Haüy, Abbé R. St. Just, work of, 15 *et seq.*; and Mitscherlich, reconciliation of views, 98, 107.
- Heat, conduction of, by crystals, 233; relations to symmetry, 233.
- Helium, nature of its atoms, 87.
- Hemihedral, meaning of term, 22, 258.
- Hemimorphic, 158, 258.
- Hexagonal axis, 24; axes and axial planes, 36, 37; crystals, 24; prisms of first and second orders, 36, 37; system, 24, 271.
- Hexakis octahedron, the, 26, 53; indices of commoner representatives, 54; tetrahedra, 197, Fig. 125 (Plate XXII) facing 196.
- Hjortdahl, morphotropic researches, 80.
- Holohedral, meaning of term, 22, 258.
- Homogeneity of crystal structure, 4.
- Homogeneous partitioning of space, 20; structures, 86, 93, 259; the 230 types, 96, 97.
- Hooke, Robert, study of alum crystals, 10.
- Hull, A. W., X-ray method of, 130.
- Huyghens, Chr., study of refraction of calcite, 11, and derivation of laws of refraction, 11.
- Hydrogen, exact atomic weight of, 91; mass of, 90; molecule, size of, 108; nature of atom of, 87, 88; nuclei, detached from atoms of other elements (Sir E. Rutherford), 91.
- Ice, crystalline form of, 31; structure of, 124, 134, 135; water flowers in, produced by heat rays, 31, Fig. 35.
- Iceland spar, 36, 37; discovery of, 11; measured crystal of, 9; rhombohedron of, 7.
- Inactive tartaric acid, 156, 157, 213; typical of true optical inactivity, 213.
- Index of refraction, 259.
- Indicatrix (Sir L. Fletcher), optical ellipsoid of doubly refractive crystals, 183, 257.
- Indices, 259; form, 7; law of rational, 40; Millerian facial, 39, 40; of Weiss, 39; of refraction, two, of uniaxial crystals, 170; three of biaxial crystals, 169, 170.
- Inert gases, 87.
- Intensity of X-ray reflection and density of plane of atoms, 118, of different orders when alternate planes differ, 118.
- Intercepts on crystal axes, 39, 40, 259.
- Interfacial angles, measured on goniometer, 55, 60; calculation of, from basal angles, 60.
- Interference bands, measurement by, 234; field of, 235, Fig. 162, 236; production of, for interferometric purposes, 234.
- „ colours, due to double refraction, 177, 194; due to optical rotation, 179, 198.
- „ figures of uniaxial and biaxial crystals in convergent polarised light, 186 (Plate XX); of aragonite, Figs. 116 and 117 (Plate XX); of calcite, Fig. 115 (Plate XX); of quartz, 189, Figs. 119, 120 and 121 (Plate XXI).
- Interferometer, a universal, 237-239, Fig. 165 (Plate XXXII); for measurement in light waves, 234, 237-239, Fig. 165 (Plate XXXII); principle of, 234.
- Ionic structure of crystals of simple binary compounds, 134.
- Iron (ferrous) sulphate, 64, 66.
- „ pyrites, structure of, 144.
- Isogonism, 79, 80, 260.
- Isomerism, chemical, 152, 260; first instance of, 155, 156; physical, 155.
- Isomorphism, 260; derivation of word, 67; discovery of (Mitscherlich), 62, 67; in broad sense, 68; true nature of, 98-107; use of, in fixing atomic weights, 69, 70.
- Isomorphous replacement in hornblende and augite groups of minerals, 70.
- „ series, variation of angles and crystal properties in, 98 *et seq.*
- Isotopes, 90; Aston's work on, 91.
- Isotropic, 260; crystals, 196.

- JAEGER, F. M.**, complex compounds exhibiting enantiomorphous crystals and large optical rotation, 164.
 „ and Haga, X-radiograms, 127.
John of Berlin, discovery of racemic acid, 155.
- KIPPING and Pope**, research on pseudo-racemism, 162, confirmation of Pasteur's law, 163.
Kopp, on morphotropy, 79.
Kundt's powder for pyro-electric tests, 159.
- LABELLING** of crystal faces, 34.
Labile shower of crystals, 45; solutions, 45; state of supersaturation, 27, 45.
Lang, Victor von, classification of crystals, 15, 22.
Langmuir, I., version of atomic structure theory, 88, 100, 146.
Laue, M. von, 251; discovery of X-ray reflection by atomic planes in crystals, 108; nature of original apparatus, 110, Fig. 69.
Laurent, research on morphotropy, 78, 79.
Lavoisier's chemical discoveries, 16.
Lead, as ultimate product of radio-activity, 91; isotopes of, 90.
Le Bel and Van t'Hoff's explanation of optical activity, 160.
Lehmann, O., crystallisation microscope, 216, Fig. 142, 229, Fig. 159; determination of temperature of transformation, 224, 225; facts substantiated concerning "liquid crystals" but explanation inadequate, 226, 227; researches on "liquid crystals," 215 *et seq.*; theory concerning them, 222, 223;
Lemery and Homberg, study of crystals of salts, 11.
Light, effect of passage through crystals, 169 *et seq.*
Limit of fine mechanical measurements, 234, 239; of fine measurement by interference bands, 234.
Limitation of crystal forms, 34, 39, 95.
Lingen, J. S. van der, X-ray analysis of "liquid crystals," 228.
Linkages between molecules in naphthalene, 134.
 "Liquid Crystals," 3, 215 *et seq.*; best substances for screen demonstration, 230; experiments with, 228-232; explanation as "swarms" by Bose, 226, 227; probable true nature of, 227, 228.
- "Liquid prisms" of ethyl ester of para-azoxy-bromocinnamic acid, 218, Fig. 152 (Plate XXVIII), 221.
Lothar Meyer's curve of atomic volumes, 142, 247.
- MAGNESIUM sulphate**, 64, 66.
Mallard and Le Chatelier's work on silver iodide, 215
Manganate, potassium, 76.
Manganates isomorphous with sulphates, 69, 76.
Manganese sulphate, 65, 66.
Margnac, atomic weights of tantalum and niobium (columbium), 69, 70; morphotropic researches, 79.
Maskelyne, N. Story, 22.
Measurement by light waves, 234 *et seq.*; limit of mechanical, 234, 239.
Median lines (first or second) of biaxial crystals, 195, 262; of gypsum, 195.
Mendeléeff, D., periodic law, 90, 262, 275.
Mercury iodide, dimorphism of, 77.
Metastable shower of crystals, 45; supersaturated solutions, 27, 45.
Methyl triphenyl pyrrolone, crystal of, 82.
- Mica-sectors plate** for testing sign of optical rotation, 200, Fig. 126.
Microphotography of crystals growing under the microscope, 3, 27.
Microscope, Lehmann's crystallisation, 216, Fig. 142, 228, 229, Fig. 159, 231, Fig. 160.
Miers, Sir Henry A., research on solubility, supersolubility and supersaturation, 43-46; on the red silver ores, 84, 85; on vicinal faces, 49-52.
Miller, W. H., origination of crystallographic descriptive method, 39, 250.
Millerian facial indices, 39; symbols of crystal faces or forms, 40.
Minimum deviation, 260.
Mirror-image symmetry, 96, 97; illustrated by quartz, 211.
Mitscherlich, E., 61 *et seq.*; alteration of crystal angles by heat, 72; ammonium salts, 69; chromates and manganates, perchlorates and permanganates, 69, 76; dimorphism of calcium carbonate, 66, 71, of mercury iodide, 77, of sodium dihydrogen phosphate, 67, of sulphur, 70, of vitriols, 66; discovery of iso-

- morphism, 62, 67, and of dimorphism, 71, of selenic acid and selenates, and isomorphism with sulphates, 76; experiment with gypsum, 72, 73; original preparation of double sulphates, 66; research on carbonates and sulphates, 63; on phosphates and arsenates, 62, 63; on vitriols, 65, 66.
- Mitscherlich experiment, improved method of demonstrating, 73-75 (Plate XIV).
- Molecular action, range of, 224.
- „ compound, racemic acid a, 160.
- „ distance ratios, 104, 261; volume, 104, 261.
- Molecule in crystals, Lehmann's "liquid crystal" results, 224; non-recognition in simple binary compounds, 134; persistence of, in crystal, 134, 145.
- Molécules constituantes, élémentaires, intégrantes of Haüy, 17; soustractives, 18.
- Monochromatic illuminator, 187, 188, Fig. 118.
- Monoclinic axes and axial planes, 35, 36, 37; system, 26, 273.
- Morphology of crystals, elements of, 60.
- Morphotropy, 78 *et seq.*, 261.
- Moseley, H. G. J., 250; law governing atomic structure, 90, 106.
- Muthmann, W., research on permanganates, 77, 99.
- NAPHTHALENE, crystal unit of, 141; molecule of, 141; structure of, 132, 133; unit cell of, 132.
- „ tetrachloride, 78.
- Naumann, obsolete symbols of, 240.
- Neon yellow light, use of, in interferometry, 235.
- Newland's law of octaves, 90, 262.
- Newton's rings, 261; seven orders of spectra, 178, 261.
- Nickel sulphate, 65, 66.
- Nicklès, research on morphotropy, 78, 79.
- Nicol prism, construction of, 176, 184, 262; explanation of, 184.
- Nitrobenzenes and nitrophenols, von Groth's researches on, 81.
- Nitrogen atoms, disruption of, by α -particles, 91.
- Noble, Sir Andrew, experiments on liquefaction of carbon, 152.
- Nuclei of atoms, dimensions of, 92; of helium (α -particles), 92.
- Number of crystallised substances, 240, 249.
- Ogg, A., and F. L. Hopwood, structure of alkali sulphates, 129; their X-ray analysis, 245, 246, Fig. 92.
- Optic axes of biaxial crystals, 183, 254; axis of uniaxial crystals, 170, 182, 254, of quartz, 176; axial angle goniometer, 187, 188, Fig. 118; axial angle and plane, 262.
- Optical activity, 266; and enantiomorphism, 160; activity, essential condition for, 163, of quartz, 181; antipodes, 161, enantiomorphous crystals of, 161.
- Optically active classes of crystals, 160.
- Order of polarisation colours for right and left quartz plates, 180.
- Ostwald, W., conditions for crystallisation, 43.
- Oxides of arsenic and antimony, isodimorphism of, 71.
- PARA-azoxy-anisol, "liquid crystals" of, 217, 218, Fig. 144 (Plate XXVIII), 220, Fig. 154 (Plate XXIX), 221, 230.
- „ azoxy-benzoic acid, "liquid crystals" of, 220.
- „ azoxy-bromocinnamic acid, "liquid crystals" of, 218, Fig. 152 (Plate XXVIII), 221.
- „ azoxy-phenetol, "liquid crystals" of, 217, Fig. 143; discovery of (Gattermann), 217.
- Parallel polarised light, experiments in, 193 *et seq.*
- Parallelohedron, 262.
- Parametral face and forms, 38; plane, 38, 262.
- Pasteur, Louis, centenary of, coincident with determination of structure of tartaric and racemic acids, 135, 137, 139; discovery of relation between enantiomorphism and optical activity, 155, of truly inactive tartaric acid, 156, of lævo-tartaric acid, 159; explanation of racemic acid, 156, 157; fermentation by *Penicillium glaucum*, 159; isogonal relations among tartrates, 79; synthesis of racemic acid, 160.
- Pasteur's law, 163.
- Penfield's jelly sphere for spherical projection, 54.

- Penicillium glaucum*, destruction of dextro component of racemic acid by, 159.
- Perchlorates and permanganates, isomorphism of, 69, 76.
- Periodic law of Newlands and Mendeléeff, 90, 262, Appendix III, 275.
- Pfaff, F., variations from true crystal angles, 52.
- Phases, different solid, 150.
- Phenol and resorcinol, von Groth's researches on, 81.
- Phosphates and arsenates, Mitscherlich's research on, 62, 63.
- Phosphorus, allotropy of, 152; pentachloride, 241.
- Photomicrography of growing crystals, 3, 27.
- Physical molecule, the mythical, 147; A. Fock and W. Muthmann's researches on, 147.
- Piezo-electrical movement of crystals, 238.
- Pinakoid, 263.
- Pistor's goniometer for Mitscherlich, 72.
- Plane of symmetry, 22.
- Planeness of crystal faces, 4.
- Polar distance angle (2-circle goniometry), 58.
- Polarisation colours due to double refraction, 177, 194; due to optical activity, 179.
- Polariscope, the, 184, 264; projection, 184, arranged for convergent light, 74, 185, Fig. 114, for parallel light, 193, 194, Fig. 122.
- Poles, facial, on stereographic projection, 59.
- Polymerism, 152.
- Polymorphic forms, solid phases, 149, 150.
- Polymorphism, 147 *et seq.*; Lehmann's amplification of explanation of, 152, 153.
- Pope, Sir William H., and W. Barlow, valency volume theory, 129, 141, 241-246.
- Pope, Sir W. H., and F. S. Kipping, research on pseudo-racemism, 162.
- Positive and negative uniaxial and biaxial crystals, 171, 182, 183.
- Potassium bichromate crystallised from metastable and labile solutions, 47, 48, Plate XII.
- „ cadmium cyanide crystals, 28, Fig. 24 (Plate V).
- „ chloride, 241; crystal structure of, 117; mode of combination of K and Cl atoms, 89.
- Potassium ferricyanide crystals, 29, Fig. 32 (Plate IX); ferrocyanide crystals, 28, Fig. 27 (Plate VI).
- „ hydrogen tartrate crystals, 28, Fig. 28 (Plate VII).
- „ nickel sulphate, crystal of, 23, 66; stereographic projection of, 23.
- „ phosphate and arsenate, 62, 63, 67.
- „ selenate, first preparation of (Mitscherlich), 76.
- „ sodium carbonate crystals, 29, Fig. 31 (Plate VIII).
- „ sulphate, 9; a crystal of, 128.
- Priestley's discovery of oxygen, 16.
- Primary faces and forms, 38.
- Primitive circle of stereographic projection, 59, 265; form of Romé de l'Isle, 13, of Haüy, 18.
- Prism, 265; 60°, mode of cutting for crystal refractive index determinations, 170, 171; two spectra from, in doubly refracting crystals, 102, Fig. 66, 169; use of, 169.
- Progressive change of crystal angles in isomorphous series, 98, 100, Fig. 65; of double refraction, 102, Fig. 66; of molecular volume and distance ratios, 99, 104; of position of optical ellipsoid, 103.
- Projection apparatus for convergent polarised light, 185, Fig. 114, parallel light, 194, Fig. 122; for "liquid crystals," 231, Fig. 160.
- Proton, hydrogen nucleus, ultimate unit of matter, 88.
- Proustite and pyrargyrite, Miers' researches on, 84, 85; difference of rhombohedral angles of, 85.
- Prout's hypothesis, 88.
- Pseudo-racemism, 162, 211.
- Pyro-electric properties of crystals, 161; of two tartaric acids, dextro and laevo, 159.
- QUARTZ, behaviour of, in polarised light, 177, in thin plates, 177, in thick plates, 179; crystal, liquid cavity with salt crystals in, 30; cavities with carbonic acid, 30; crystals, right- and left-handed, 174, Figs. 111 and 110, small determinative faces of, 174, 175; explanation of polarisation colours of, 180; objects carved out of, 213, 214, Fig. 141 (Plate XXVII), spheres of, 214; plates, preparation of, 181, in parallel polarised light, 198, rotation colours of, 198, rotation for different thicknesses and wave-

- lengths, 198; 60°-prism of, experiments with, 171-173, modes of cutting, 171; refractive indices of, 176; structure of, 125, 126; train of prisms of, 171, mode of cutting, 171; twins (Brazilian) of, 201, Figs. 127 and 128, in polarised light, 204, 205, Fig. 134 (Plate XXIV), Fig. 135 (Plate XXV), repeated, 204, Fig. 133 of frontispiece.
- RACEMIC acid**, Pasteur's explanation and synthesis of, 156, 159, 160; Scacchi's anhydrous form of, 157; structure of (Astbury), 137-139; sodium ammonium salt of, Pasteur's work on, 158.
- Racemism**, 162, 265; elucidated by experiments with amethyst quartz, 212, 213.
- Radioactivity**, 90, 250; of uranium and radium, 90; of thorium, 91.
- Radium**, 90, 250.
- Rammelsberg, C.**, morphotropy, 79.
- Ramsay, Sir Wm.**, and Lord Rayleigh, discovery of inert gases, 250.
- Rational indices**, law of, 19, 34, 40, 94, 95, 265; Haiiy's discovery of, 19.
- Ratios of the crystal axes**, 38.
- Rays**, ordinary and extraordinary, 265.
- Red hydrogen or cadmium light**, sources of, 235.
- Reflection from crystal faces**, 5, 6, 55, 266.
- Refraction**, 266.
- Refractive index**, meaning of, 172, 259; indices, three, of biaxial crystals, 169, 170, two, of uniaxial crystals, 171; determination of, 170, 171.
- Regular point systems**, 95, 96, 266.
- Reinitzer**, work on cholesteryl benzoate, 217.
- Repeated twinning and pseudo-racemism**, 162.
- Replacement**, 269.
- Reticular density and crystal growth**, 50; and primary faces, 50.
- Reusch, E. von**, simulation of quartz by mica piles, 191, 192.
- Rhombic axes and axial planes**, 35, 37; system, 26, 273.
- Rhombohedron**, a deformed cube, 36, 39; the, and its axes, 36, 37, 175, Fig. 112.
- Richards, Theodore**, compressibility of atoms and valency volume theory, 246.
- Right- and left-handed optical rotation**, convention concerning, 180.
- Rings and brushes**, optic axial, 186, 187, Plate XX.
- Rinne, F.**, X-radiograms, 127, 128.
- Rock-salt**, cube of, in quartz cavity, 30, Fig. 34 (Plate X); 60°-prism of, experiment with, 169; spacing of cube planes, 117; structure of, 115, 116, 119, Figs. 75 and 77.
- Romé de l'Isle**, work of, 12, 13; research on alums, 65.
- Röntgen, W. C. von**, 108, 250.
- Rotation of plane of polarisation**, 266; by quartz of two varieties and different thicknesses, 179, 180, 198, 199; convention for right- or left-handedness, 180.
- Royal Institution experiment with diamonds**, 5.
- Rubidium and ammonium salts**, isostructure of, 105, 129, 245; valency volumes of sulphates, 245.
- Rulings by H. J. Grayson**, one forty-thousandth inch apart, 239; best resolution for, 239.
- Rutherford, Sir Ernest**, researches on atomic structure, 87, 250, and its disruption by α -particles, 91.
- SALOL and betol**, crystallisation of (Miers), 46.
- Sand grains with growth of quartz crystals**, 2.
- Saturation and supersaturation**, 43-47, 266.
- Scacchi, A.**, preparation of anhydrous racemic acid, 137.
- Scheele's discovery of tartaric acid**, 155.
- Schlippe's salt crystals**, 29, Fig. 33 (Plate IX).
- Schoenflies, A.**, the 230 point systems, 96, 97, 154; "Fundamentalbereich," of, 86.
- Screw structure of quartz crystals**, 191.
- Seebeck, A.**, researches on ammonia, 68.
- Selenates**, isomorphous with sulphates, 76; of alkalies, 98, selenic acid, 76.
- Selenite even films in parallel polarised light**, 194, 195, designs for polariscope, 196, twin in polarised light, 196.
- Selenium**, discovery by Berzelius, 76.
- Sella's warning as to hasty generalisation**, 80.
- Senarmontite**, 71.
- Seven crystal systems**, 22.
- Shearer, G.**, law connecting symmetry of crystal and molecule, 140.
- Signal slit of goniometer**, 56, 102, Fig. 66.
- Silver iodide**, contraction of, by heat, 215; dimorphism of, 215; Lehmann's work with, 215; Mallard and Le Chatelier's researches, 215; Sollas's researches, 246.

- Single refraction of cubic crystals, 169, 182.
- Snow crystals, 32, Fig. 36 (Plate X); on Mont Blanc, 33; on Mt. Palū, 32.
- Sobrerol, isogonism of, 162.
- Sodium ammonium racemate, 158, Pasteur's and Gernez' separation into two forms, 158, 159.
- „ chlorate, optical activity lost on solution, 161.
- „ chloride, crystal structure of, 115, 116, 119, Figs. 75 and 77.
- „ dihydrogen phosphate, 67.
- „ light, unsuitability of, for interferometer, 235.
- „ phosphate, 67.
- „ sulphantimoniate crystals, 29.
- Sohncke, L., 65 regular point systems, 95, 96, 154; screw point systems of quartz, 161.
- Solid angle, 267.
- Sollas, W., theory of crystal structure, 142, 246.
- Solubility and super-solubility, 43-47; curves of, 44, 45, Fig. 47.
- Solutions, labile and metastable, 45; optically active, 161; cases of loss of activity on dissolving crystal, 161.
- Space-lattice, 21, 267; 14 types of (Bravais), 94, parallelepipedal unit cells, 20, 93, 94, 95; cubic, 116, Fig. 75; importance of (Miers), 50; triclinic, 94.
- Specific gravity of crystals, importance of, 104, 243.
- Sphere of jelly (Penfield), 54.
- Spheres of influence of atoms, 93, 244.
- Spherical projection, 54.
- Spiral structure of quartz, 126, 199; Rensch's imitation of, by mica piles, 191, 192.
- Spot-pattern, Laue X-radiogram, 109; each spot on two circles, 120; intensities of spots, 121.
- Steno, Nicolaus, measurements of quartz crystals, 11.
- Stereographic projection, 23, 59, 267; of potassium nickel sulphate, 23, Fig. 16; of topaz, 59, Fig. 54; of X-radiograms, 120.
- Stereometric arrangement of atoms in molecule, 100, 149, 267.
- Strain, effect of, on behaviour of isotropic crystal, 196, 197; polarisation colours of glass and diamond due to, 196, 197, Fig. 125 (Plate XXII).
- Structural constants, molecular volume and topic axial ratios, 243; units, 16, 268; of tangible size, 34.
- Struvite, 29.
- Sublimation, 268.
- Sulphates and selenates (rhombic) of alkalis, and double salts with $6H_2O$ (monoclinic), researches on, 98-106, main results of, 98, 99; diagram of change in angles, 100, in double refraction, 102, in rotation of optical ellipsoid, 103; explanation of results by Bragg's and Moseley's laws, 106, 142, 143; final generalisation, 103; positions of ammonium and thallium salts, 105; progression in axial angles and average angular changes, 101; in space-lattice cell dimensions, 105.
- Sulphates of barium, strontium, and lead, 63, 64.
- Sulphur atoms, diameter of, 144; dimorphism of, 70, 151; monoclinic crystals of, 3, 70; rhombic crystal of, Fig. 104 (Plate XIX) facing 150.
- „ hexachloride, 242.
- Supersaturation, labile and metastable, 27, 45, 266.
- Sylvine, structure of, 117, spacing of cube planes, 117, X-radiogram of, 120, Fig. 78.
- Symbol of a face or form, 39, 40, 268.
- Symmetry axes and planes, 22, as criteria for classification of crystals, 27; elements of, 22, 268; operations of first and second order, 268.
- Systems, the seven crystal, 4, 22, 269;
- TARTARIC acid, constitution of, 156; crystal elements of, 135; dextro and lævo forms of, 157, 158, Figs. 105 and 106; discovery of dextro by Scheele, 155, of lævo by Pasteur, 156, 159, of inactive form by Pasteur, 156; pyro-electric properties of, 159; structure of, 135-137.
- Tetartohedral, meaning of term, 22, 269.
- Tetragonal axis, 24; prism, 35; system, 24, 272.
- Thallium, relation of, to alkalis, 105, 106; sulphate and selenate, 105, 106; isomorphous but not eutropic, with alkali salts, 106.
- Theodolite goniometer, 57, 58.
- Thermal expansion of alkali sulphates, 104, 237.
- Thompson, S. P., mica sectors experiment for sign of rotation, 200

- Thomson, J. M., researches on super-saturation, 43.
 ,, Sir Joseph J., 89, 250.
 Tint of passage, 180, 269.
 Topaz, 35, 37; crystal of, 26, Fig. 22; stereographic projection of, 59, Fig. 54; X-radiogram of, 127 and Plate XVIII.
 Topic axial ratios, 104, 261.
 Torsometer, 237, 238, Fig. 165 (Plate XXXII).
 Transition violet tint, 180, 269; of quartz plates, 180.
 Triclinic axes and axial planes, 36, 37; equivalent of octahedron, 38; system, 26, 274.
 Trigonal axes and axial planes, 24, 36; system, 25, 272.
 Triphenyl pyrrolone, methyl, ethyl, and propyl, isodimorphous relations of, 82-84.
 Triple tartrate of sodium, potassium, and ammonium, crossed-axial-plane dispersion of, 73; 76.
 Truncation, 269.
 Two-circle method of goniometry, 58; goniometer, 57, Fig. 53.
 UNIAXIAL crystals, 270; optic axis of, 176, 182; 60°-prisms of, 170, 173; two refractive indices of, 170, 171-173.
 Unit-cell of space-lattice, relative sizes of, in isomorphous series, 104; of crystal structure, the grosser molecular or polymolecular, 95, the ultimate atomic, 95.
 Urea, effect of, in crystallisation of ammonium chloride, 49.
 VALENCY, chemical, 241; volume theory, 241-246.
 Valentinite, 71.
 Vanadium family group of elements, 69.
 Vegard, L., structure of alums, crystal water part of structure, 128.
 Vicinal faces, 270; explanation of, 51; Miers' researches on, 49; of alum, 49-51.
 Vitriols, the, 10, 64, 65, 66.
 Voigt, W., torsion apparatus of, 237.
 Vorländer's "liquid crystals" of para-azoxy-benzoic acid, 220, and of p.-a.-bromocinnamic acid, 218, Fig. 152 (Plate XXVIII), 221; favourable conditions for "liquid crystals," 226, 227.
 WATER, abnormal expansion on cooling, 31; expansion of, on freezing, explanation of, 125; of crystallisation, 64, 65, 128.
 ,, -flowers in ice produced by heat rays, 31.
 Wave-lengths of light, measurement by, 234-239.
 Weiss, symbols of, 39.
 Werner's fundamental form, 14.
 Westfeld, calcite rhombohedra, 12.
 White of higher orders, 179.
 Wollaston, 250; invention of reflecting goniometer, 55, 250; researches on carbonates and sulphates, 63, 64.
 Wulff, G. W., directive force of crystallisation, 51; reticular density and crystal growth, 50.
 Wyckoff, R. W. G., special cases of the 230 space-groups, 144.
 X-RADIOGRAM, the original (Laue), of zinc blende, 109 and Plate XVI.
 X-ray analysis of crystals, 108 *et seq.*; main results of, 143; methods of Bragg and Laue compared, 130, of Debye and Scherrer and of Hull, 130.
 X-rays, wave-lengths of, 108.
 YOUNG'S modulus of elasticity, determination of, for crystals, 233, 237, 238, Fig. 164.
 ZINC blende, first X-ray experiment with, 108; original X-radiogram of, Fig. 68 (Plate XVI) facing 108; structure of, 121, 123.
 ,, sulphate, 64, 66.
 Zone, 270; axis, 54; circle, 54; crystal faces distributed in zones, 53 *et seq.*; of faces, reviewed on goniometer, 55.

